



HEBEI HAIHAO GROUP

河北海浩集团

至精至信、为实为新

To be professional and honest ,
to be pragmatic and innovative

www.haihaopiping.com

www.haihaogroup.com

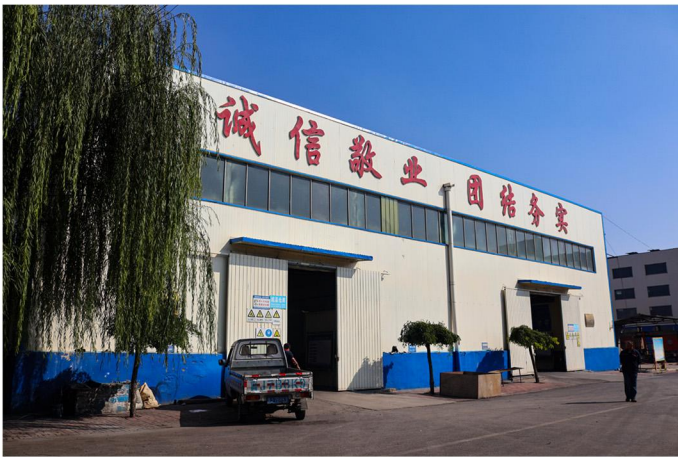

公司简介

Company Profile

Hebei Haihao High Pressure Flange Pipe Fitting Group Co.,Ltd was established in 1982, located in Mengcun County-the hometown of pipe fittings in China. We are the first and one of the biggest companies which can produce pipe fittings, flanges and steel pipes. Our Group owns subsidiaries, there are more than 660 employers, including 26 engineers, 48 assistant engineers and 68 technicians. The Group covers 850,000 square meters and owns fixed assets 5,000,000. The output can be up to 80,000 tons and the annual turnover is around 80,000,000 Products of Hebei Haihao Group are used all over the industrial filed of China, and exported to the Middle East, Southeast Asia, Europe,Russia and other countries. Our products are divided four series: 1,flange & pipe fittings; 2,pre-fabricated; 3,overlay cladding; 4,coating & lining, hundreds type of products by carbon steel, alloy steel and stainless steel.

Hebei Haihao Group owns advanced production lines. Products are manufactured by forging, cold pressing, cold forming, hot extrusion, heat treatment, polishing, rubbing, machining and chrome finishing. There are many advanced machines,such as heat treatment furnaces, automatic welding machines, large lathe and inspection devices more than 100 sets.

Quality makes markets and honesty serves clients. We welcome you to pay a visit to our company for cooperation and mutual development.



管道连接世界，技术服务全球
 Connecting the world through pipelines, providing global technical services



生产设备照片 Production Equipment Photos



海浩产品系列 HAIHAO PRODUCT SERIES



对焊管件 BUTT WELD PIPE FITTING

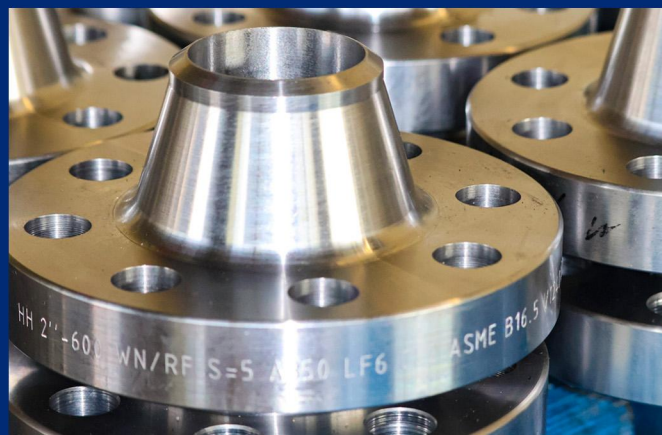

法兰 FLANGE



钢管 STEEL PIPE



锻件 FORGING



孔板法兰 ORIFICE FLANGE



垫片螺栓螺母 GASKET & BOLT & NUT

检验与实验设备

Inspection and
Experimental
Equipment



高温拉伸试验机
High temperature tensile
testing machine

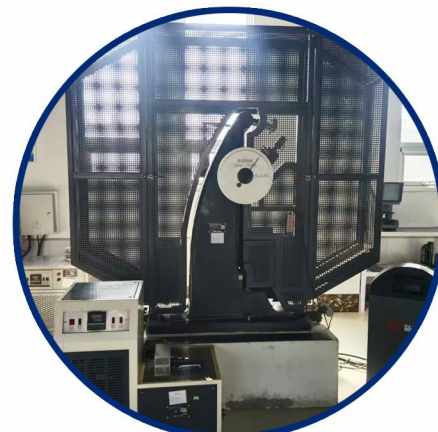

冲击试验机
Impact testing machine



内外涂层 INTERNAL & EXTERNAL COATING



预制管道 PRE-FABRICATED



3PE涂层 3PE COATING

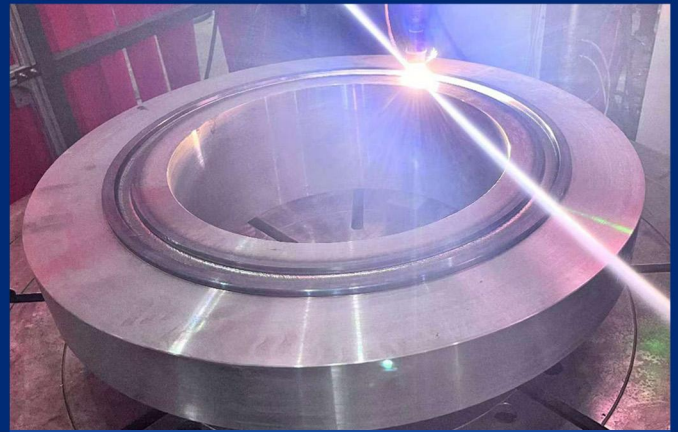

堆焊产品 WELD OVERLAY CLAD PRODUCT



锻件 FORGING



封头 HEAD

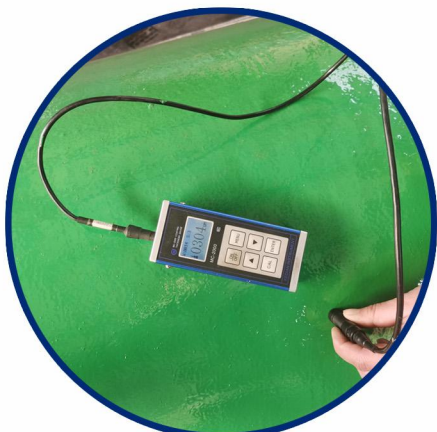

涂层厚度检测
Coating thickness inspection



渗透检测
Liquid penetrant testing



晶间腐蚀E法试验
IGC testing

资质证书 QUALIFICATION CERTIFICATES



美国船级社证书
ABS CERTIFICATE

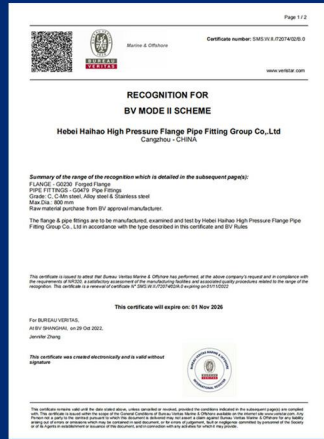

法国船级社证书
BV CERTIFICATE

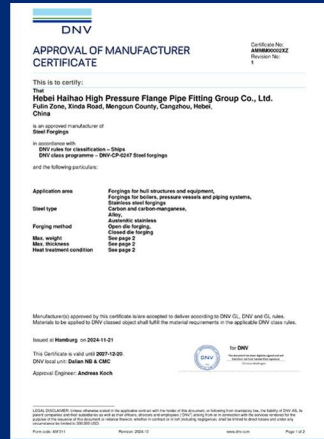

挪威船级社证书
DNV CERTIFICATE

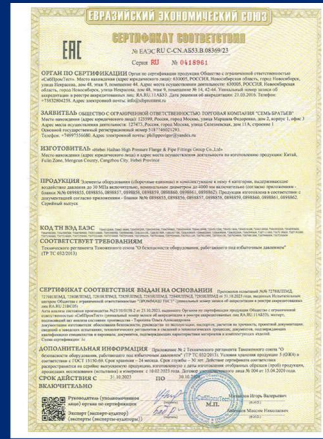

EAC证书
EAC CERTIFICATE



PED证书
PED CERTIFICATE

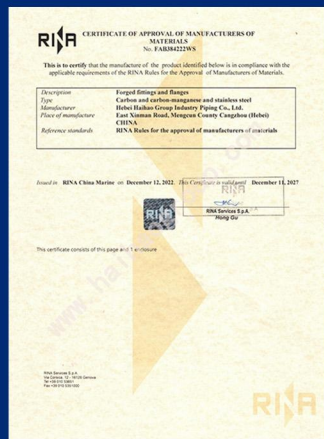

意大利船级社证书
RINA CERTIFICATE

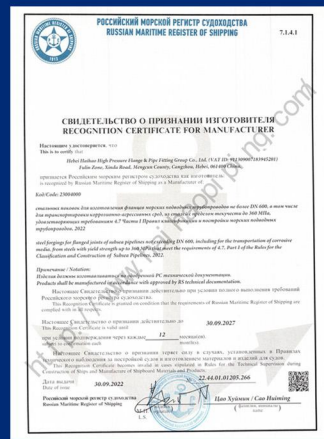

俄罗斯船级社证书
RMRS CERTIFICATE

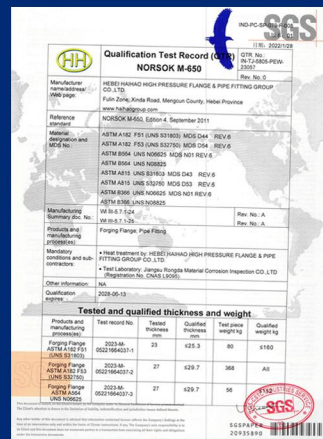

NORSOK M650证书
NORSOK M650 CERTIFICATE



API Q1证书
API Q1 CERTIFICATE

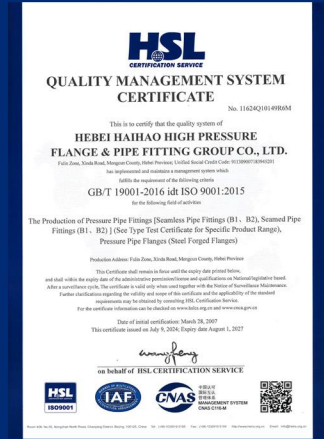

ISO 9001证书
ISO 9001 CERTIFICATE

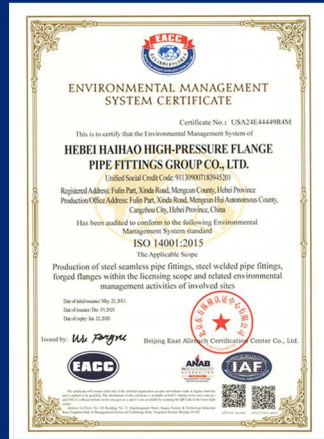

ISO 14001证书
ISO 14001 CERTIFICATE

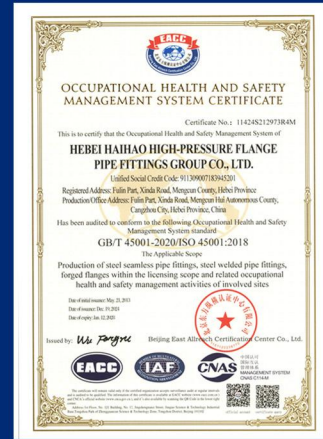

ISO 45001证书
ISO 45001 CERTIFICATE



压扁试验
Flattening test

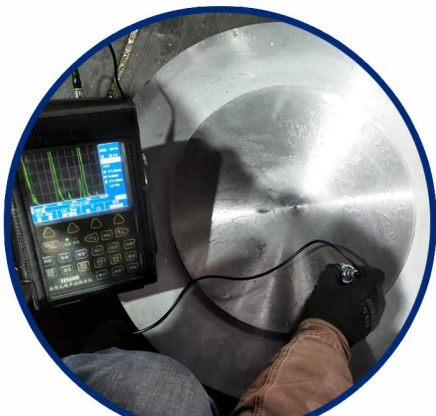

超声检测
Ultrasonic testing



水压实验
Hydraulic test



Precision Engineered, Performance Proven

Advanced FEA & Design Calculations for Piping & Flanges

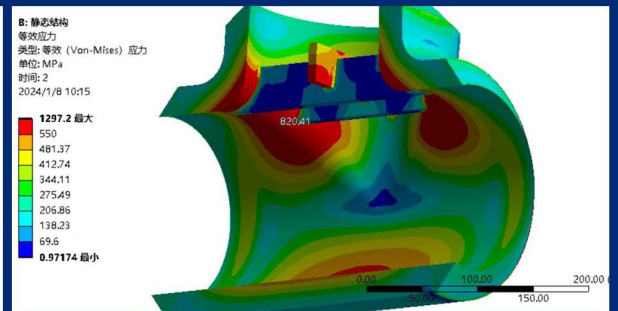
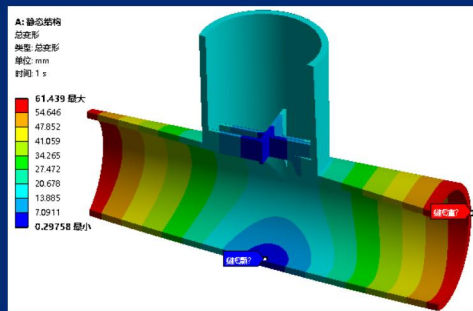
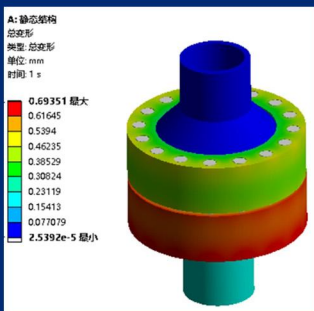

FILE SUPPORT
文件支持



RICH EXPERIENCE
IN TRANSPORTATION
运输经验丰富



VTB COLLECTION
VTB 收款



成为管道技术和材料领域的可靠伙伴
To be a reliable partner in the field of pipeline technology and materials

www.haihaopiping.com

www.haihaogroup.com

Email: sales@haihaogroup.com

Phone/WhatsApp: 86-15533741638

中国·天津 TIANJIN·CHINA | 中国·沧州 CANGZHOU·CHINA | 中国·孟村 MENGUN·CHINA

商务中心 Business Center

中国天津市西青区榕苑路15号鑫茂科技园军民园1号楼B座503
503, Block B, Building 1, Military and Civilian Park, Xinmao Science and Technology Park, 15 Rongyuan Road, Xiqing District, Tianjin, China

商务中心 Business Center

中国河北省沧州市北京路文化大厦7层
7Floor, Culture Plaza, Beijing Road, Cangzhou City, Hebei Province, China

生产中心 Production Center

河北省沧州市孟村县城北工业区
Fulin Zone Xinda Road, Mengcun County, Cangzhou City, Hebei Province, China



产品范围

COMPANY CERTIFICATES



	Flanges
Type	Weld neck Flange, Slip on Flange, Plate Flange, Blind Flange, Socket weld Flange, Threaded Flange, Lap Joint Flange, LWN Flange, Orifice Flange, Spectacle Blind, Spades & Ring Spacers.
Size	1/2" to 192"; DN15-DN4800
Face	RF, FF, MF, MFM, RJ, TG, RTJ, SRF.
Pressure	Class 150Lbs, 300Lbs, 600Lbs, 900Lbs, 1500Lbs, 2500Lbs; PN6, PN10, PN16, PN20, PN25, PN40, PN63, PN100; 5K, 10K, 16K, 20K, 30K, 40K, 63K.
Standard	ASME/ANSI B16.5, B16.47, ASME B16.36, AWWA C207. DIN 2527, 2573, 2576, 2631, 2632, 2633, 2634, 2635, 2566, 2642. EN 1092, BS 4504, JIS B2220, GOST 10820, GOST 10821, SABS 1123, AS 1219 etc.
Material	Carbon steel: ASTM A105, A350 LF2, SS400, P235GH, P250GH, C22.8, Q235, 20#, 16Mn.
	Stainless steel: ASTM A182 F304, F304L, F316, F316L, F321, F347, F310, F44, F51, etc
	Alloy steel: ASTM A694 F42, F46, F52, F56, F60, F65, F70, A182 F5, F9, F91, F12, F11, F22 etc.



产
品
范
围

COMPANY CERTIFICATES



	Butt Weld Pipe Fittings
Type	Elbows, Tees, Lateral Tees, Reducers, Caps, Bends, Crosses, Stub Ends, Insulation joints, Saddles.
Size	1/2"- 72"; DN15-DN1800
Wall thickness	SCH5S, SCH10S, SCH10, SCH20S, SCH20, SCH40S, SCH40, SCH80S, SCH80, SCH120, SCH160, STD, XS, XXS
Applicable standard	ASME/ANSI B16.9, ASME/ANSI B16.11, MSS SP-75, MSS SP-43, BS EN 10253, DIN2605, 2609, 2615, 2616, 2617, DIN28011, GOST 17375, 17376, 17378, 17379, 17380, 30753, JIS B2311, JIS B2312, JIS B2313, JIS B2316, ISO 3419, ISO 5251, etc
Material	Carbon steel, Stainless steel, Alloy steel: ASTM A105, A182 F5, F9, F11, F12, F22, A234 WPB, WP5, WP9, WP11, WP12, WP22, WP91, A403 WP304L, WP316L, WP321, ASTM A420 WPL6, ASTM A860 WPHY42, WPHY52, WPHY60, WPHY65, WPHY70, JIS G3454, BS EN10253, S235, S355, DIN ST37, ST52, GOST CT20.



产
品
范
围

COMPANY CERTIFICATES



	Forged Steel Pipe Fittings
Type	Elbows, Tees, Crosses, Unions, Plugs, Caps, Coupling, Socket, Outlet, Swage Nipple, Bushing, Boss.
Size	1/2" to 24"; DN15-DN600 .
Connection	Socket welding, Butt welding, Threaded.
Pressure	Class 2000, Class 3000, Class 6000, Class 9000, Class 15000.
Standard	ASME/ANSI B16.5, EN 10241.
Material	Carbon steel: ASTM A105, A350 LF2, SS400, P235GH, P250GH, C22.8, Q235, 20#, 16Mn.
	Stainless steel: ASTM A182 F304, F304L, F316, F316L, F321, F347, F310, F44, F51, etc.
	Alloy steel: ASTM A694 F42, F46, F52, F56, F60, F65, F70, A182 F5, F9, F91, F12, F11, F22 etc.



河北海浩

FLANGES WELD ON PIPES DIN 2573.....	019	BLND FLANGES DIN 2527 PN16.....	028
FLANGES WELD ON PIPES DIN 2576.....	020	BLND FLANGES DIN 2527 PN25.....	028
FLANGES WELD ON PIPES DIN 2502.....	021	BLND FLANGES DIN 2527 PN40.....	029
FLANGES WELD ON PIPES DIN 2503.....	022	WELDING NECK FLANGES DIN 2631.....	030
LAPPED FLANGES WITH COLLAR DIN 2642...	024	WELDING NECK FLANGES DIN 2632.....	031
LAPPED FLANGES WITH COLLAR DIN 2655...	025	WELDING NECK FLANGES DIN 2633.....	032
LAPPED FLANGES WITH COLLAR DIN 2656...	025	WELDING NECK FLANGES DIN 2634.....	033
SCREWED PIPE FLANGES DIN2566.....	026	WELDING NECK FLANGES DIN 2635.....	034
BLND FLANGES DIN 2527 PN6.....	027	WELDING NECK FLANGES DIN 2636.....	035
BLND FLANGES DIN 2527 PN10.....	027	WELDING NECK FLANGES DIN 2637.....	035



德标
法兰参数系列



河北海浩

5Kg/Cm ² JIS B2220-1984(KSB 1503-1999).....002	30Kg/Cm ² WELDING NECK STEEL PIPE FLANGES.....010
10Kg/Cm ² JIS B2220-1984(KSB 1503-1999).....003	40Kg/Cm ² WELDING NECK STEEL PIPE FLANGES.....011
16Kg/Cm ² JIS B2220-1984(KSB 1503-1999).....004	63Kg/Cm ² WELDING NECK STEEL PIPE FLANGES.....012
20Kg/Cm ² JIS B2220-1984(KSB 1503-1999).....005	KSV 7815 JIS F 7805 1K.....013
30Kg/Cm ² JIS B2220-1984(KSB 1503-1999).....006	KSB 1511-1987 JIS B 2220-1977 2K.....014
40Kg/Cm ² JIS B2220-1984(KSB 1503-1999).....007	5K SET-ON FLANGE JIS B 2220-1999.....015
10Kg/Cm ² WELDING NECK STEEL PIPE FLANGES.....008	10K SET-ON FLANGE JIS B 2220-1999.....016
20Kg/Cm ² WELDING NECK STEEL PIPE FLANGES.....009	KS B2332-1994 & KS D 4308 KS B 2333-1995.....017



日标
法兰参数系列

5Kg/Cm²

JIS B2220-1984(KSB 1503-1999)

5Kg/Cm² SLIP-ON WELDING STEEL PIPE FLANGES

SOP TYPE
NOMINAL SIZE 10-1000A

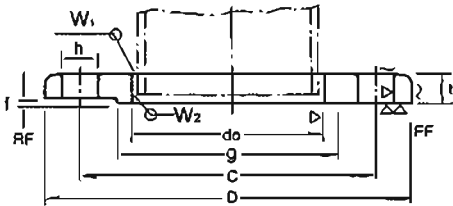

SOH TYPE
NOMINAL SIZE 450-1000A

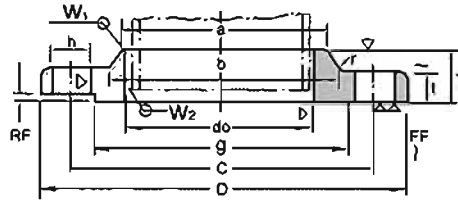

BL TYPE
NOMINAL SIZE 10-750A

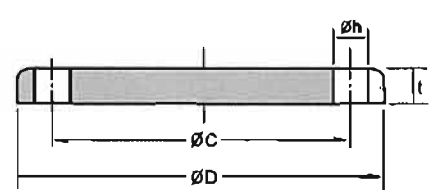

Unit:mm

Nominal Bore of Flange	Outside Diam.of Appli cable Pipe	Inside Diam.of Flange do	Outside Diam.of Flange D	Sectional Dimensions of Flange							Dia.of Bolt			Nominal Bolt Size	Weight(kg)		
				t	T	Diam.of Hub		Rad -ius r	Raised face f	Diam.of Raised Face g	Diam.of Bolt Circle C	Number of Bolt Holes	Hole Diam h		SOP	BL	SOH
						a	b										
(10)	17.3	17.8	75	9	-	-	-	-	1	39	55	4	12	M10	0.27	0.3	-
15	21.7	22.2	80	9	-	-	-	-	1	44	60	4	12	M10	0.30	0.4	-
(20)	27.2	27.7	85	10	-	-	-	-	1	49	65	4	12	M10	0.37	0.5	-
25	34.0	34.5	95	10	-	-	-	-	1	59	75	4	12	M10	0.45	0.6	-
(32)	42.7	43.2	115	12	-	-	-	-	2	70	90	4	15	M12	0.78	0.9	-
40	48.6	49.1	120	12	-	-	-	-	2	75	95	4	15	M12	0.83	1.0	-
50	60.5	61.1	130	14	-	-	-	-	2	85	105	4	15	M12	1.07	1.4	-
65	76.3	77.1	155	14	-	-	-	-	2	110	130	4	15	M12	1.49	2.0	-
80	89.1	90.0	180	14	-	-	-	-	2	121	145	4	19	M16	1.99	2.7	-
(90)	101.6	102.6	190	14	-	-	-	-	2	131	155	4	19	M16	2.09	3.0	-
100	114.3	115.4	200	16	-	-	-	-	2	141	165	8	19	M16	2.39	3.7	-
125	139.8	141.2	235	16	-	-	-	-	2	176	200	8	19	M16	3.23	5.2	-
150	165.2	166.6	265	18	-	-	-	-	2	206	230	8	19	M16	4.41	7.5	-
(175)	190.7	192.1	300	18	-	-	-	-	2	232	260	8	23	M20	5.51	9.5	-
200	216.3	218.0	320	20	-	-	-	-	2	252	280	8	23	M20	6.33	12.2	-
(225)	241.8	243.7	345	20	-	-	-	-	2	277	305	12	23	M20	6.64	14.0	-
250	267.4	269.5	385	22	-	-	-	-	2	317	345	12	23	M20	9.45	19.3	-
300	318.5	321.0	430	22	-	-	-	-	3	360	390	12	23	M20	10.3	24.3	-
350	355.6	358.1	480	24	-	-	-	-	3	403	435	12	25	M22	14.0	33.2	-
400	406.4	409.0	540	24	-	-	-	-	3	463	495	16	25	M22	16.9	41.9	-
450	457.2	460.0	605	24	40	495	500	5	3	523	555	16	25	M22	21.6	53.0	24.8
500	508.0	511.0	655	24	40	546	552	5	3	573	605	20	25	M22	23.1	61.9	26.9
550	558.8	562.0	720	26	42	597	603	5	3	630	665	20	27	M24	30.3	81.2	34.1
600	609.6	613.0	770	26	44	648	654	5	3	680	715	20	27	M24	32.7	93.2	37.5
650	660.4	664.0	825	26	48	702	708	5	3	735	770	24	27	M24	35.9	106.9	42.8
700	711.2	715.0	875	26	48	751	758	5	3	785	820	24	27	M24	38.2	120.6	45.4
750	762.0	766.0	945	28	52	802	810	5	3	840	880	24	33	M30	48.7	150.5	57.4
800	812.8	817.0	995	28	52	854	862	5	3	890	930	24	33	M30	51.2	167.4	60.8
(850)	863.6	868.0	1046	28	54	904	912	5	3	940	980	24	33	M30	64.4	185.1	63.5
900	914.4	919.0	1095	30	56	956	964	5	3	990	1030	24	33	M30	61.1	218.1	75.3
1000	1016.0	1021.0	1195	32	60	1058	1066	5	3	1090	1130	28	33	M30	70.5	277.3	88.5
*(1100)	1117.6	1123	1305	32	-	-	-	-	3	1200	1240	28	33	M30	81.7	331.9	-
*1200	1219.2	1225	1420	34	-	-	-	-	3	1305	1350	32	33	M30	102.0	417.8	-
*1350	1371.6	-	1575	34	-	-	-	-	3	1460	1505	32	33	M30	115.9	515.6	-
*1500	1524.0	-	1730	36	-	-	-	-	3	1615	1660	36	33	M30	157.4	659.2	-

- 1.Flanges of parenthesized nominal diameter had letter not be used.
- 2.The facing of flanges shall conform to KS B1509(JIS B2202)1984.
- 3.Nominal diameter over 1000 is manufacturer' s standard(*)



10Kg/Cm²

JIS B2220-1984(KSB 1503-1999)

10Kg/Cm² SLIP-ON WELDING STEEL PIPE FLANGES

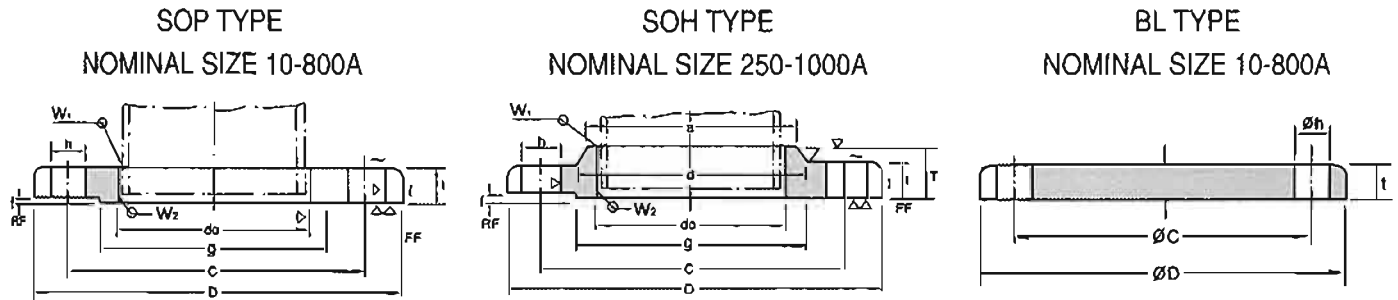

NORMAL THICKNESS FLANGE

Unit:mm

Nominal Diam of Flange	Outside Diam.of Steel Pipe	Inside Diam.of Flange do	Outside Diam.of Flange D	Sectional Dimensions of Flange							Dia.of Bolt			Nominal Bolt Size	Weight(kg)		
				t	T	Diam.of Hub		Rad- ius r	Raised Face f	Diam.of Raised Face g	Bolt Circle Diam. C	Number of Bolt Holes	Hole Diam h		SOP	BL	SOH
						a	b										
10	17.3	17.8	90	12	-	-	-	-	1	46	66	4	15	M12	0.52	0.54	-
15	21.7	22.2	95	12	-	-	-	-	1	51	70	4	15	M12	0.57	0.61	-
20	27.2	27.7	100	14	-	-	-	-	1	56	75	4	15	M12	0.73	0.79	-
25	34.0	34.5	125	14	-	-	-	-	1	67	90	4	19	M16	1.13	1.24	-
32	42.7	43.2	135	16	-	-	-	-	2	76	100	4	19	M16	1.48	1.66	-
40	48.6	49.1	140	16	-	-	-	-	2	81	105	4	19	M16	1.56	1.81	-
50	80.5	81.1	155	16	-	-	-	-	2	96	120	4	19	M16	1.88	2.23	-
65	76.3	77.1	175	18	-	-	-	-	2	116	140	4	19	M16	2.60	3.3	-
80	89.1	90	185	18	-	-	-	-	2	128	150	8	19	M16	2.61	3.5	-
(90)	101.6	102.6	195	18	-	-	-	-	2	136	160	8	19	M16	2.76	4.0	-
100	114.3	115.4	210	18	-	-	-	-	2	151	175	8	19	M16	3.14	4.6	-
125	139.8	141.2	250	20	-	-	-	-	2	182	210	8	23	M20	4.77	7.3	-
150	165.2	166.6	280	22	-	-	-	-	2	212	240	8	23	M20	6.34	10.1	-
(175)	190.7	192.1	305	22	-	-	-	-	2	237	265	12	23	M20	6.82	11.8	-
200	216.3	218	330	22	-	-	-	-	2	262	290	12	23	M20	7.53	14.0	-
(225)	241.8	243.7	350	22	-	-	-	-	2	282	310	12	23	M20	7.74	15.8	-
250	267.4	269.5	400	24	36	288	292	6	2	324	355	12	25	M22	11.8	22.7	12.7
300	318.5	321	445	24	38	340	346	6	3	368	400	16	25	M22	12.7	27.8	13.8
350	355.6	358.1	490	26	42	380	386	6	3	413	445	16	25	M22	16.4	37.1	18.2
400	406.4	409	560	28	44	436	442	6	3	475	510	16	27	M24	23.0	52.5	25.2
450	457.2	460	620	30	48	496	502	6	3	530	565	20	27	M24	29.5	68.8	33.0
500	508	511	675	30	48	548	554	6	3	585	620	20	27	M24	33.5	82.1	37.6
(550)	558.8	562	745	32	52	604	610	6	3	640	680	20	33	M30	43.1	105.8	49.7
600	609.6	613	795	32	52	656	662	6	3	690	730	24	33	M30	45.7	120.2	52.6
(650)	660.4	664	845	34	56	706	712	6	3	740	780	24	33	M30	52.1	145.0	60.6
700	711.2	715	905	34	58	762	770	6	3	800	840	24	33	M30	59.5	167.2	70.6
(750)	762	766	970	36	62	816	824	6	3	855	900	24	33	M30	73.2	204.2	85.8
800	812.8	817	1020	36	64	868	876	6	3	905	950	28	33	M30	76.4	225.4	91.2
(850)	863.6	868	1070	36	66	920	928	6	3	955	1000	28	33	M30	80.7	248.8	98.6
900	914.4	919	1120	38	70	971	979	6	3	1005	1050	28	33	M30	89.4	288.4	109.0
1000	1016	1021	1235	40	74	1073	1081	6	3	1110	1160	28	39	M36	109.2	367.7	133.0
*1100	1117.6	1123	1345	42	76	-	-	-	3	1220	1270	28	39	M36	131.6	460.0	-
*1200	1219.2	1225	1465	44	78	-	-	-	3	1325	1380	32	39	M36	163.5	572.2	-
*1350	1371.6	-	1630	48	82	-	-	-	3	1480	1540	36	45	M42	204.7	769.0	-
*1500	1524.0	-	1795	50	90	-	-	-	3	1635	1700	40	45	M42	250.2	974.9	-

1. Flanges of parenthesized nominal diameter had letter not be used.
2. The facing of flanges shall conform to KS B1509(JIS B2202)1984.
3. Nominal diameter over 1000 is manufacturer's standard(*).

16Kg/Cm²

JIS B2220-1984(KSB 1503-1999)

16Kg/Cm² SLIP-ON WELDING STEEL PIPE FLANGES

SOH TYPE
NOMINAL SIZE 10-600A

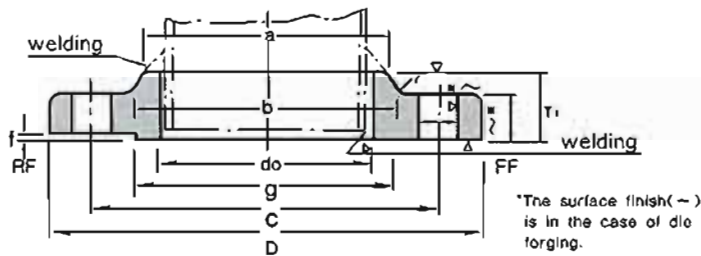

BL TYPE
NOMINAL SIZE 10-600A

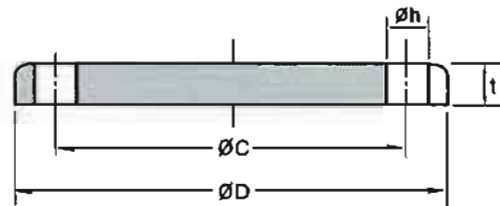

Unit:mm

Nominal Diameter of Flange	Outside Diameter of Steel Pipe	Inside Diameter of Flange do	Sectional Dimensions of Flange								Bolt Hole			Nominal Bolt Size	Weight(kg)		
			Outside Diameter of Flange D	t	T	Diam. of Hub		Rad-ius r	f	g	Bolt Circle Diameter C	Number of Bolt Holes	Hole Diameter h		SOP	BL	SOH
						a	b										
10	17.3	17.8	90	12	16	26	28	4	1	46	65	4	15	M12	0.52	0.54	0.52
15	21.7	22.2	95	12	16	30	32	4	1	51	70	4	15	M12	0.57	0.61	0.58
20	27.2	27.7	100	14	20	38	42	4	1	56	75	4	15	M12	0.73	0.79	0.75
25	34.0	34.5	125	14	20	46	50	4	1	67	90	4	19	M16	1.13	1.24	1.16
32	42.7	43.2	135	16	22	56	60	5	2	76	100	4	19	M16	1.48	1.66	1.53
40	48.6	49.1	140	16	24	62	66	5	2	81	105	4	19	M16	1.56	1.81	1.64
50	60.5	61.1	155	16	24	76	80	5	2	98	120	8	19	M16	1.8	2.3	1.83
65	76.3	77.1	175	18	26	94	98	5	2	116	140	8	19	M16	2.5	3.1	2.58
80	89.1	90.0	200	20	28	108	112	6	2	132	160	8	23	M20	3.5	4.5	3.66
(90)	101.6	102.6	210	20	30	120	124	6	2	145	170	8	23	M20	3.7	5.0	3.95
100	114.3	115.4	225	22	34	134	138	6	2	160	185	8	23	M20	4.5	6.3	4.94
125	139.8	141.2	270	22	34	164	170	6	2	195	225	8	25	M22	6.5	9.2	7.0
150	165.2	166.6	305	24	38	196	202	6	2	230	260	12	25	M22	8.7	12.8	9.62
200	216.3	218.0	350	26	40	244	252	6	2	275	305	12	25	M22	10.9	18.6	12.1
250	267.4	269.5	430	28	44	304	312	6	2	345	380	12	27	M24	18.0	30.6	20.0
300	318.5	321.0	480	30	48	354	364	8	3	395	430	16	27	M24	21.5	40.7	24.4
350	355.6	358.1	540	34	52	398	408	8	3	440	480	16	33	M30 x 3	30.8	57.8	35.0
400	406.4	409.0	605	38	60	446	456	10	3	495	540	16	33	M30 x 3	42.8	82.2	46.2
450	457.2	460.0	675	40	64	504	514	10	3	560	605	20	33	M30 x 3	55.1	107.6	61.9
500	506.0	511.0	730	42	68	558	568	10	3	615	660	20	33	M30 x 3	65.1	133.1	73.25
(550)	558.8	562.0	795	44	70	612	622	10	3	670	720	20	39	M36 x 3	77.9	164.1	88.1
600	609.6	613.0	845	46	74	666	676	10	3	720	770	24	39	M36 x 3	86.0	193.2	98.8
(650)	660.4	664	895	48	77	704	726	10	5	770	820	24	39	M36 x 3	96.3	227.5	101.0
700	711.2	715	960	50	80	754	776	10	5	820	875	24	42	M36 x 3	114.1	272.6	120.0
(750)	762.0	766	1020	52	83	806	832	10	5	880	935	24	42	M39 x 3	132.7	321.9	141.0
800	812.8	817	1085	54	86	865	885	10	5	930	990	24	48	M45 x 3	152.1	375.6	161.0
(850)	863.6	868	1135	56	89	916	936	10	5	980	1040	24	48	M45 x 3	166.5	428.1	177.0
900	914.4	919	1185	58	93	968	986	10	5	1030	1090	28	48	M45 x 3	178.1	481.8	191.0
1000	1016.0	1021	1320	62	99	1070	1098	12	5	1140	1210	28	56	M52 x 3	235.3	636.0	230.0
1100	1117.6	1123	1420	66	105	1180	1200	12	5	1240	1310	32	56	M52 x 3	267.9	784.0	289.0
1200	1219.2	1225	1530	70	112	1262	1302	12	5	1350	1420	32	56	M52 x 3	321.1	972.4	348.0
1300	1320.8	1326.0	1645	74	-	-	-	-	5	1450	1530	32	62	-	378.6	1165.2	-
1350	1371.6	1377.0	1700	76	-	-	-	-	5	1510	1590	32	62	-	410.0	1303.8	-
1400	1422.4	1428.0	1755	78	-	-	-	-	5	1560	1640	36	62	-	436.0	1422.5	-
1500	1524.0	1529.0	1865	80	-	-	-	-	5	1670	1750	36	62	-	496.4	1665.6	-

1. Flanges of parenthesized nominal diameter had better not be used.

2. For dimensional tolerance, refer to JIS B2203.

3. In principle material shall be SS400 specified in JIS G3101, SF390A(or SF440A) specified in JIS G3201, or S20C(or S25C) specified in JIS G4051, and shall be fit for welding.



20Kg/Cm²

JIS B2220-1984(KSB 1503-1999)

20Kg/Cm² SLIP-ON WELDING STEEL PIPE FLANGES

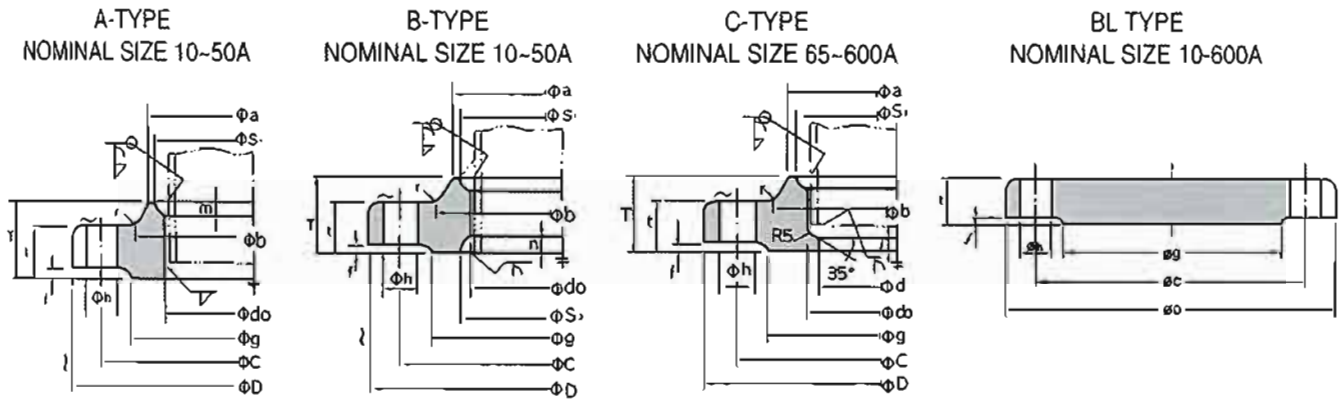

*The surface finish(▽) is in the case of die forging.

Unit:mm

Nominal Diameter of Flange	Outside Diameter of Steel Pipe	Inside Diameter of Flange do	Outside Diameter of Flange D	Sectional Dimensions of Flange										Bolt Hole				Reference					Weight(kg)		
				t	T	Diameter of Hub		Rad-ius r	f	g	d	Bolt Circle Diameter C	Num-ber of Bolt Holes	Hole Dia- meter h	Nominal Bolt Size	S ₁	m	S ₂	n	l	SOP	BL	SOH		
						a	b																		
10	17.3	17.8	90	14	20	30	32	4	1	46	-	65	4	15	M12	27	4	27	4	-	0.6	0.6	0.59		
15	21.7	22.2	95	14	20	34	36	4	1	51	-	70	4	15	M12	31	4	31	4	-	0.7	0.7	0.65		
20	27.2	27.7	100	16	22	40	42	4	1	56	-	75	4	15	M12	37	4	37	4	-	0.8	0.8	0.81		
25	34.0	34.5	125	18	24	48	50	4	1	67	-	90	4	19	M16	44	4	44	4.5	-	1.3	1.5	1.29		
32	42.7	43.2	135	18	26	56	60	5	2	76	-	100	4	19	M16	52	4	53	5	-	1.6	1.8	1.6		
40	48.6	49.1	140	18	26	62	66	5	2	81	-	105	4	19	M16	58	4	59	5.5	-	1.7	2.0	1.69		
50	60.5	61.1	155	18	26	76	80	5	2	98	-	120	8	19	M16	70	4	72	5.5	-	1.9	2.4	1.89		
65	78.3	77.1	175	20	30	100	104	5	2	116	65.9	140	8	19	M16	94	6	85	6	6	2.6	3.4	2.8		
80	89.1	90.0	200	22	34	113	117	6	2	132	78.1	160	8	23	M20	107	6	-	6	3.8	4.9	3.93			
(90)	101.6	102.6	210	24	36	126	130	6	2	145	90.2	170	8	23	M20	120	6	-	6	4.4	6.0	4.56			
100	114.3	115.4	225	24	36	138	142	6	2	160	102.3	185	8	23	M20	132	6	-	6	4.9	6.9	5.13			
125	139.8	141.2	270	28	40	166	172	6	2	195	126.6	225	8	25	M22	160	7	-	6	7.8	11.0	8.3			
150	165.2	168.8	305	28	42	196	202	6	2	230	151.0	260	12	25	M22	186	8	-	6	10.1	14.9	10.6			
200	216.3	218.0	350	30	46	244	252	6	2	275	199.9	305	12	25	M22	237	9	-	6	12.6	21.4	13.3			
250	267.4	269.5	430	34	52	304	312	6	2	345	248.8	380	12	27	M24	290	10	-	6	21.9	37.2	23.4			
300	318.5	321.0	480	38	58	354	364	8	3	395	297.9	430	16	27	M24	345	11	-	6	25.8	48.8	27.7			
350	355.6	358.1	540	40	62	398	408	8	3	440	333.4	480	16	33	M30 x 3	384	12	-	6	36.2	68.0	39.2			
400	406.4	409.0	605	46	70	446	456	10	3	495	381.0	540	16	33	M30 x 3	437	13	-	7	51.7	99.4	54.2			
450	457.2	460.0	675	48	78	504	514	10	3	560	431.8	605	20	33	M30 x 3	480	15	-	7	66.1	129.1	71.7			
500	508.0	511.0	730	50	84	558	568	10	3	615	482.6	660	20	33	M30 x 3	544	16	-	7	77.4	158.4	86.2			
(550)	558.8	562.0	795	52	90	612	622	10	3	670	533.4	720	20	39	M36 x 3	606	16	-	7	92.2	194.0	105			
600	609.6	613.0	845	54	96	666	676	10	3	720	584.2	770	24	39	M36 x 3	648	18	-	7	101.1	226.9	119			
(650)	660.4	664.0	945	60	-	-	-	-	5	790	-	850	24	48	M45 x 3	-	-	-	-	147.8	311.6	-			
700	711.2	715.0	995	64	-	-	-	-	5	840	-	-	-	-	-	-	-	-	-	168.0	370.9	-			
(750)	762.0	766.0	1080	68	-	-	-	-	5	900	-	970	24	56	M52 x 3	-	-	-	-	212.7	460.1	-			
800	812.8	817.0	1140	72	-	-	-	-	5	960	-	1030	24	56	M52 x 3	-	-	-	-	248.5	546.5	-			
(850)	863.6	868.0	1200	74	-	-	-	-	5	1020	-	1090	24	56	M52 x 3	-	-	-	-	280.5	626.2	-			
900	914.6	919.0	1250	76	-	-	-	-	5	1070	-	1140	28	56	M52 x 3	-	-	-	-	298.9	694.9	-			

- 1.Flanges of parenthesized nominal diameters had better not be used.
 - 2.The Flange gasket surface is based on large raised facing specified in JIS B2202.
 - 3.Size d is an example of pipe thickness for schedule 40 of JIS G3454.and JIS G3456 .But customers can order for other size as occasion demand.
 - 4.For dimensional tolerance,refer to JIS B2203.
 - 5.In principle, material shall be aSS400 specified in JIS G3101, SF390A(or SF440A)specified in JIS G3201, or S20C(or S25C) specified in JIS G4051.Material shall be fit for welding.
- *The surface finish is the case of forging (▽:In other cases).

30Kg/Cm²

JIS B2220-1984(KSB 1503-1999)

30Kg/Cm² SLIP-ON WELDING STEEL PIPE FLANGES

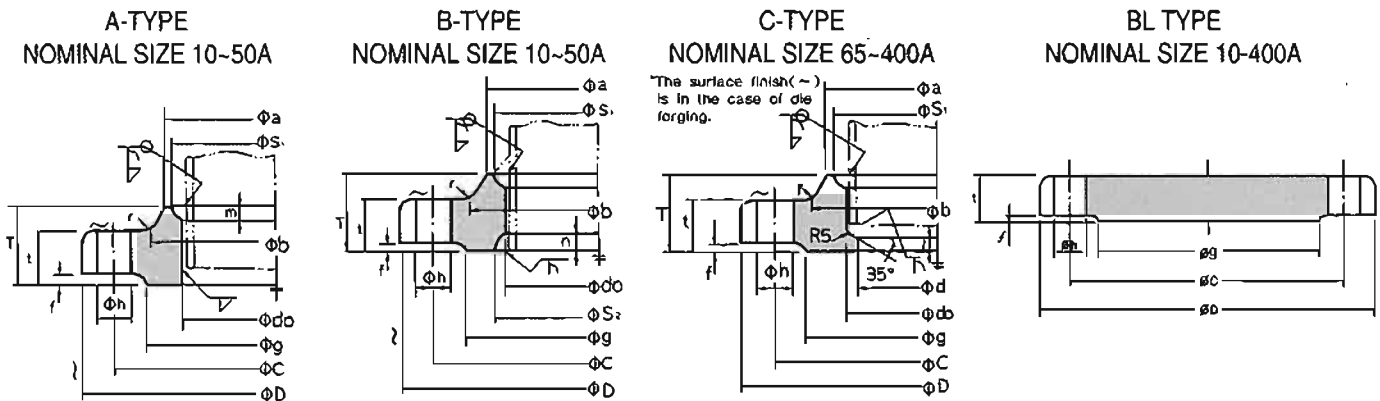

Unit: mm

Nominal Diameter of Flange	Outside Diameter of Steel Pipe	Inside Diameter of Flange do	Outside Diameter of Flange D	Sectional Dimensions of Flange										Bolt Hole				Reference					Approx Weight (kg)	
				t	T	Diameter of Hub		Radius r	f	g	d	Bolt Circle Diameter C	Number of Bolt Holes	Hole Diameter h	Nominal Bolt Size	S ₁	m	S ₂	n	l	SOH	BL		
						a	b																	
10	17.3	17.8	110	16	24	30	34	4	1	52	—	75	4	19	M16	—	—	—	—	—	0.99	1.00		
15	21.7	22.2	115	18	26	36	40	5	1	55	—	80	4	19	M16	31	4	40	5	—	1.23	1.25		
20	27.2	27.7	120	18	28	42	46	5	1	60	—	85	4	19	M16	37	5	44	5	—	1.34	1.38		
25	34.0	34.5	130	20	30	50	54	5	1	70	—	95	4	19	M16	44	6	52	5	—	1.76	1.84		
32	42.7	43.2	140	22	32	60	64	6	2	80	—	105	4	19	M16	52	6	60	5	—	2.15	2.32		
40	48.6	49.1	160	22	34	66	70	6	2	90	—	120	4	23	M20	58	6	66	5	—	2.82	3.00		
50	60.5	61.1	165	22	36	82	86	6	2	105	—	130	8	19	M16	70	8.5	78	5	—	2.89	3.14		
65	76.3	77.1	200	26	40	102	106	8	2	130	65.9	160	8	23	M20	96	9.5	94	5	6	4.70	5.50		
80	89.1	90.0	210	28	44	115	121	8	2	140	78.1	170	8	23	M20	109	9.5	—	—	6	5.36	6.63		
(90)	101.8	102.6	230	30	46	128	134	8	2	150	90.2	185	8	25	M22	122	9.5	—	—	6	6.85	8.55		
100	114.3	115.4	240	32	48	141	147	8	2	160	102.3	195	8	25	M22	135	9.5	—	—	6	7.89	10.0		
125	139.8	141.2	275	36	54	166	172	8	2	195	128.6	230	8	25	M22	160	9.5	—	—	6	11.4	15.3		
150	165.2	166.6	325	38	58	196	204	8	2	235	151.0	275	12	27	M24	186	9.5	—	—	6	16.7	22.2		
200	216.3	218.0	370	42	64	248	256	8	2	280	199.9	320	12	27	M24	237	9.5	—	—	6	20.6	32.6		
250	267.4	269.5	450	48	72	306	314	10	2	345	248.8	390	12	33	M30 × 3	290	10	—	—	6	36.1	55.2		
300	318.5	321.0	515	52	78	360	370	10	3	405	297.9	450	16	33	M30 × 3	345	12	—	—	6	49.9	77.9		
350	355.6	358.1	560	54	84	402	412	12	3	450	333.4	495	16	33	M30 × 3	383	13	—	—	6	61.2	96.9		
400	406.4	409.0	630	60	92	456	468	15	3	510	381.0	560	16	39	M36 × 3	435	14	—	—	7	85.2	136		

- As far as possible, nominal diameter in parenthesis should be avoided from use.
- The dimensional tolerances shall conform to JIS B2203.
- The flange gasket surface is based on large raised facing specified in JIS B2202. But, if necessary, facings other than the Large raised facing specified in JIS B2201 can be designated by customers.
- Sized is an example of pipe thickness for schedule 40 of JIS G3454 and JIS B3456. When other size is necessary, customers can order it at will.
- Material
 Carbon Steel: S25C specified in JIS G4051, or S440A specified in JIS G3201.
 Molybdenum steel: 1/2 Mo steel specified in tables 1 and 2 of JIS B2215.
 Chromium-Molybdenum steel: 1/4 Cr 1/2 Mo Steel specified in tables 1 and 2 of JIS B2215.
 * The surface finish is in the case of forging (Δ: in other cases)



40Kg/Cm²

JIS B2216

40Kg/Cm² SLIP-ON WELDING STEEL PIPE FLANGES

NOMINAL SIZE 10-65mm

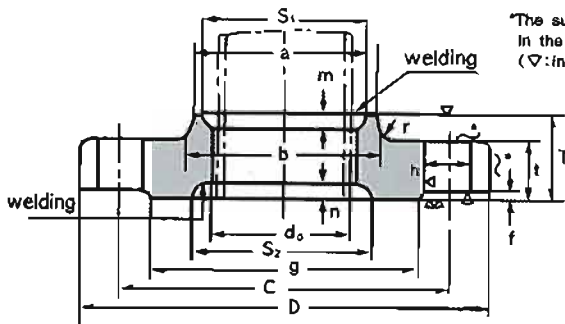

NOMINAL SIZE 65-400mm

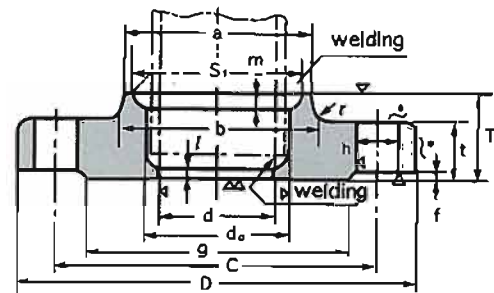

Unit:mm

Nominal Diameter of Flange	Outside Diameter of Steel Pipe	Inside Diameter of Flange do	Outside Diameter of Flange D	Sectional Dimensions of Flange								Bolt Hole			Reference					Approx Weight (kg)	
				t	T	Diameter of Hub		Rad-ius r	f	g	d	Bolt Circle Diameter C	Num-ber of Bolt Holes	Hole Dia-meter h	Nominal Bolt Size	S ₁	m	S ₂	n		l
						a	b														
10	17.3	17.8	110	18	26	34	38	5	1	52	-	75	4	19	M16	28.0	6	28	5		1.11
15	21.7	22.2	115	20	30	39	43	5	1	55	-	80	4	19	M16	32.5	6	32.5	5		1.39
20	27.2	27.7	120	20	30	45	49	5	1	60	-	85	4	19	M18	38.0	6	38.0	5		1.51
25	34.0	34.5	130	22	32	55	59	5	1	70	-	95	4	19	M16	47.8	6	47.8	5		1.97
32	42.7	43.2	140	24	35	64	68	6	2	80	-	105	4	19	M16	56.5	6	56.5	5		2.50
40	48.6	49.1	160	24	35	70	74	6	2	90	-	120	4	23	M20	62.5	6	62.5	5		3.26
50	60.5	61.1	165	26	38	85	90	6	2	105	-	130	8	19	M16	74.5	6	74.5	5.5		3.47
65	76.3	77.1	200	30	44	106	110	8	2	130	62.3	160	8	23	M20	91.5	7	91.5	7		5.97
80	89.1	90.3	210	32	46	118	124	8	2	140	73.9	170	8	23	M20	105.5	7.5	105.5	7		6.76
100	114.3	115.4	250	36	52	145	151	8	2	165	97.1	205	8	25	M22	133.0	8.5	133.0	7		10.78
125	139.8	141.4	300	40	58	182	188	8	2	200	120.8	250	8	27	M24	160.5	9.5	160.5	7		16.97
150	165.2	167.0	355	44	64	200	208	8	2	240	143.2	295	12	33	M30	188.0	11	188.0	7		22.8
200	216.3	218.2	405	50	72	255	263	8	2	290	190.9	345	12	33	M30	243.0	13	243.0	7		34.9
250	267.4	269.5	475	56	80	310	318	10	2	355	237.2	410	12	33	M30	298.0	15	298.0	7		41.1

1. As far as possible, nominal diameter in parenthesis should be avoid from use.
2. The dimensional tolerance shall confirm to JIS B2203.
3. The flange gasket surface is based on large raised facing specified in JIS B2202. But, if necessary, facings other than the large raised facing specified in JIS B2201 can be designated by customers.
4. Size d is an example of pipe thickness for schedule 40 of JIS G3454 and JIS B3456. when other size is necessary, customers can order it at will.
5. Refer to JIS B2216.

10Kg/Cm² WELDING NECK FLANGES

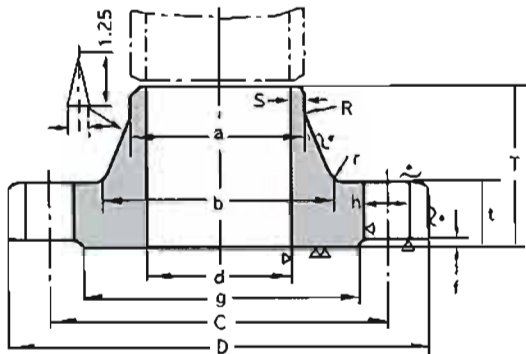

The surface finish shown above is in the case of forging (▽marks: in other cases)

Reference: Beveling

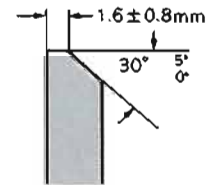

When particularly necessary, customers can order another beveling form the above.

Nominal Diam of Flange	Outside Diam of Steel Pipe	Inside Diam of Flange d	Outside Diam of Flange D	Sectional Dimensions of Flange										Nominal Bolt Size	Length of wecr Depat P ⁴	Approx Weight (kg)
				t	T ¹	Diam of Hub		Radius r ³	Raised Face f	Diam of Raised Face g	Bolt Circle Diameter	Number of Bolt Holes	Hole Diam h			
						a	b									
10	17.3	To be specified by purchaser	90	12	28.9	17.3	25	4	1	46	65	4	15	M12	3.5	
15	21.7		95	12	30.6	21.7	33	4	1	51	70	4	15	M12	4.5	
20	27.2		100	14	33.9	27.2	38	4	1	56	75	4	15	M12	6.4	
25	34		125	14	36.3	34.0	47	4	1	67	90	4	19	M16	6.0	
32	42.7		135	16	40.3	42.7	57	5	2	76	100	4	19	M16	6.4	
40	48.6		140	16	41.2	48.6	64	5	2	81	105	4	19	M16	5.9	
50	60.5		155	16	42.9	60.5	77	5	2	96	120	4	19	M16	6.3	
65	76.3		175	18	53.0	76.3	97	5	2	116	140	4	19	M16	9.1	
80	89.1		185	18	53.0	89.1	109	6	2	126	150	8	19	M16	9.6	
(90)	101.6		195	18	50.6	101.6	120	6	2	136	160	8	19	M16	9.6	
100	114.3		210	18	54.3	114.3	135	6	2	151	175	8	19	M16	10.4	
125	139.8		250	20	56.2	139.8	160	6	2	182	210	8	23	M20	10.9	
150	165.2		280	22	65.3	165.2	190	6	2	212	240	8	23	M20	12.3	
(175)	190.7		305	22	66.1	190.7	215	6	2	237	265	12	23	M20	13.7	
200	216.3		330	22	66.1	216.3	240	6	2	262	290	12	23	M20	14.4	
(225)	241.8		350	22	62.3	241.8	262	6	2	282	310	12	23	M20	15.0	
250	267.4		400	24	70.7	267.4	292	6	2	324	355	12	25	M22	15.9	
300	318.5		445	24	75.9	318.5	346	6	3	368	400	16	25	M22	17.5	
350	355.6		490	26	83.0	355.6	386	8	3	413	445	16	25	M22	19.0	
400	406.4		560	28	94.4	406.4	442	8	3	475	510	16	27	M24	21.9	
450	457.2		620	30	107.9	457.2	502	10	3	530	565	20	27	M24	21.9	
500	508		675	30	110.2	508.0	554	10	3	585	620	20	27	M24	22.7	
550	558.8		745	32	119.9	558.8	610	10	3	640	680	20	33	M30	23.9	
600	609.6		795	32	123.6	609.6	662	10	3	690	730	24	33	M30	26.1	

- ¹ ² ⁴ DIMENSIONS OF "T" "T" "S" "P" ARE MAKER, JUNG ANG' S STANDARD.
- ² UNDER NOMINAL SIZE 225m/m & UNDER DIMENSION OF "b" IS MAKER, JUNG ANG' S STANDARD.
- ALL DIMENSIONS OF FLANGE WAS DESIGNED ON JIS B2220 & B1503 BASE



20Kg/Cm²
WELDING NECK STEEL PIPE FLANGES

Reference: Beveling

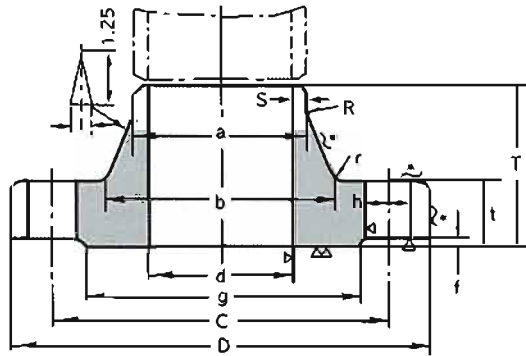

*The surface finish shown above is in the case of forging (▽marks: in other cases)

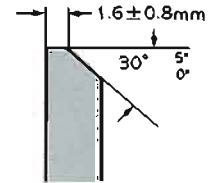

When particularly necessary, customers can order another beveling form the above.

Nominal Diameter of Flange	Outside Diameter of Steel Pipe	Outside Diameter of Flange D	Sectional Dimensions of Flange										Bolt Hole			Nominal Bolt Size	Approx Weight (kg)	
			t	d	a	b	S	T	P	Radius	f	g	Bolt Circle Diameter C	Number of Bolt Holes	Diameter of Hole h			
10	17.3	90	14		17.3	32			35.9	3.5	4	1	46	65	4	15	M12	
15	21.7	95	14		21.7	36			36.4	4.5	4	1	51	70	4	15	M12	
20	27.2	100	16		27.2	42			40.9	6.4	4	1	56	75	4	15	M12	
25	34.0	125	16	To be specified by purchaser.	34.0	50	To be specified by purchaser.		42.0	6.0	4	1	67	90	4	19	M16	
32	42.7	135	18		42.7	60		46.0	6.4	5	2	76	100	4	19	M16		
40	48.6	140	18		48.6	66		45.7	5.9	5	2	81	105	4	19	M16		
50	60.5	155	18		60.5	80		48.7	6.3	5	2	96	120	8	19	M16		
65	76.3	175	20		76.3	104		63.7	9.1	5	2	116	140	8	19	M16		
80	89.1	200	22		89.1	117		66.5	9.6	6	2	132	160	8	23	M20		
90	101.6	210	24		101.6	130		68.9	9.4	6	2	145	170	8	23	M20		
100	114.3	225	24		114.3	142		69.0	10.4	6	2	160	185	8	23	M20		
125	139.8	270	26		139.8	172		77.2	10.9	6	2	195	225	8	25	M22		
150	165.2	305	28		165.2	202		86.3	12.3	6	2	230	260	12	25	M22		
200	216.3	350	30	216.3	252	89.0	14.4	6	2	275	305	12	25	M22				
250	267.4	430	34	267.4	312	105.7	15.9	6	2	345	380	12	27	M24				
300	318.5	480	36	318.5	364	110.4	17.5	8	3	395	430	16	27	M24				
350	355.6	540	40	355.6	408	124.5	19.0	8	3	440	480	16	33	M30×3				
400	406.4	605	46	406.4	456	129.9	21.9	10	3	495	540	16	33	M30×3				
450	457.2	675	48	457.2	514	140.9	21.9	10	3	560	605	20	33	M30×3				
500	508.0	730	50	508.0	568	147.7	22.7	10	3	615	660	20	33	M30×3				
550	558.8	795	52	558.8	622	154.9	23.9	10	3	670	720	20	39	M36×3				
600	609.6	845	54	609.6	676	163.1	26.1	10	3	720	770	24	39	M36×3				

NOTE: DIMENSIONS ARE MAKER JUNO ANG STANDARD AND DESIGN BASE IS JIS B2220-1984

30Kg/Cm²

JIS B2220-1984(KSB 1503-1999)

WELDING NECK STEEL PIPE FLANGES

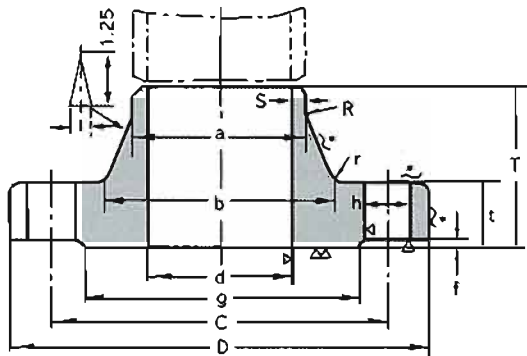

The surface finish shown above is in the case of forging (▽marks:in other cases)

Reference:Beveling

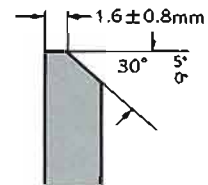

When particularly necessary, customers can order another beveling form the above.

Nominal Diameter of Flange	Outside Diameter of Steel Pipe	Outside Diameter of Flange D	Sectional Dimensions of Flange										Bolt Hole			Nominal Bolt Size	Approx Weight (kg)
			t	d	a	b	S	T	R	Radius r	f	g	Bolt Circle Diameter C	Number of Bolt Holes	Hole Diameter h		
15	21.7	115	18	15.8	22.0	40	3.1	45	20	6	1	55	85	4	19	M16	1.33
20	27.2	120	18	21.1	27.5	44	3.2	45	20	6	1	60	85	4	19	M16	1.47
25	34.0	130	20	26.8	34.4	52	3.8	48	20	6	1	70	95	4	19	M16	1.95
32	42.7	140	22	35.1	43.1	62	4.0	52	30	6	2	80	105	4	19	M16	2.43
40	48.6	160	22	40.7	49.1	70	4.2	54	30	6	2	90	120	4	23	M20	3.16
50	60.5	165	22	52.2	61.0	84	4.4	57	30	8	2	105	130	8	19	M16	3.33
65	76.3	200	26	65.3	76.9	104	5.8	69	30	8	2	130	160	8	23	M20	5.91
80	89.1	210	28	77.5	89.7	118	6.1	73	30	8	2	140	170	8	23	M20	7.05
(90)	101.6	230	30	89.5	102.3	130	6.4	74	30	8	2	150	185	8	25	M22	8.54
100	114.3	240	32	101.5	115.1	142	6.8	76	30	8	2	160	195	8	25	M22	9.72
125	139.8	275	36	125.7	140.7	172	7.5	86	50	10	2	195	230	8	25	M22	14.4
150	165.2	325	38	150.0	166.2	202	8.1	95	50	10	2	235	275	12	27	M24	20.6
200	216.3	370	42	198.7	217.5	254	9.4	102	50	10	2	280	320	12	27	M24	28.7
250	267.4	450	48	247.5	268.7	312	10.6	118	50	12	2	345	390	12	33	M30×3	47.3
300	318.5	515	52	296.4	320.0	366	11.8	127	50	15	3	405	450	16	33	M30×3	62.8
350	355.6	560	54	331.8	357.2	406	12.7	134	80	15	3	450	495	16	33	M30×3	77.0
400	406.4	630	60	379.1	408.3	462	14.6	149	80	20	3	510	560	16	39	M36×3	108.0

- REMARKS: 1. Flange of parenthesized nominal diameter had better not be used.
 2. The Flange gasket surface is based on "large raised facing" specified in JIS B2202. If necessary, customers can order for other types of facing.
 3. Size d and Size S are example for schedule 40 of JIS G3454 and JIS G3456. Customers can also order for other sizes.
 4. For dimensional tolerance, refer to JIS B2203.
 5. Material
 Carbon Steel: S25C specified in JIS G4051, or SF45 specified in JIS G3201.
 Molybdenum Steel: 1/2Mo Steel specified in tables 1 and 2 of JIS B2215.
 Chromium-Molybdenum Steel: 1/4Cr 1/2Mo Steel specified in tables 1 and 2 of JIS B2215.



40Kg/Cm²

JIS B2219-1984

WELDING NECK STEEL PIPE FLANGES

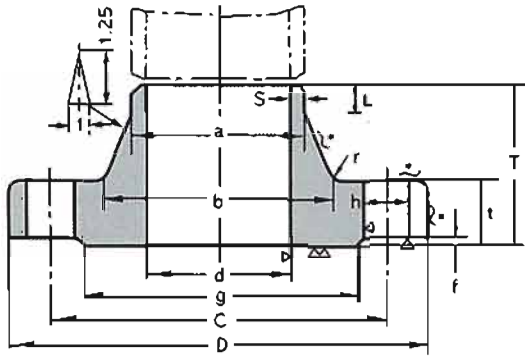

The surface finish shown above is in the case of forging (▽marks: in other cases)

Reference: Beveling

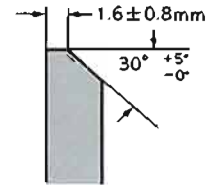

When particularly necessary, customers can order another beveling form the above.

Nominal Diameter of Flange	Outside Diameter of Steel Pipe	Outside Diameter of Flange D	Sectional Dimensions of Flange										Bolt Hole			Nominal Bolt Size	Approx Weight(kg)	
			t	d	a	b	S	T	L	Radius r	f	g	Bolt Circle Diameter C	Number of Bolt Holes	Diameter of Hole h		#40	#80
15	21.7	115	20	15.8	21.7	40	3.1	50	10	6	1	55	80	4	19	M16	1.53	1.55
20	27.2	120	20	21.1	27.2	44	3.2	50	10	6	1	60	85	4	19	M16	1.72	1.74
25	34.0	130	22	26.8	34.0	52	3.8	52	12	6	1	70	95	4	19	M16	2.24	2.28
32	42.7	140	24	35.1	42.7	62	4.0	56	14	6	2	80	105	4	19	M16	2.24	2.86
40	48.6	160	24	40.7	48.6	70	4.2	60	14	6	2	90	120	4	23	M20	2.93	3.01
50	60.5	165	26	52.2	60.5	84	4.4	64	16	8	2	105	130	8	19	M16	4.2	4.41
65	76.3	200	30	65.3	76.3	104	5.8	75	18	8	2	130	160	8	23	M20	7.32	7.52
80	89.1	210	32	77.5	89.1	118	6.1	80	18	8	2	140	170	8	23	M20	8.47	8.80
(90)	104.6	230	34	89.5	104.6	130	6.4	88	18	8	2	150	185	8	25	M22	9.4	-
100	114.3	250	36	101.5	114.3	148	6.8	90	24	8	2	165	205	8	25	M22	13.25	13.82
125	139.8	300	40	125.7	139.8	186	7.5	108	26	10	2	200	250	8	27	M24	21.64	22.5
150	165.2	355	44	150.0	165.2	218	8.1	122	30	10	2	240	295	12	33	M30	32.45	35.1
200	216.3	405	50	198.7	216.3	272	9.4	132	38	10	2	290	345	12	33	M30	45.5	47.2
250	267.4	475	56	247.5	267.4	338	10.6	138	44	12	2	355	410	12	33	M30	69.6	-
300	318.5	540	60	296.4	318.5	400	11.8	159	48	15	3	410	470	16	39	M36	96.0	-
350	355.6	585	64	331.8	355.6	432	12.7	168	50	15	3	455	515	16	39	M36	115.0	-
400	406.4	645	70	379.1	406.4	466	14.6	181	50	20	3	515	570	16	39	M36	143.0	-

- REMARKS: 1. Flange of parenthesized nominal diameter had better not be used.
 2. The Flange gasket surface is based on "large raised facing" specified in JIS B2202. If necessary, customers can order for other types of facing.
 3. Size d and Size S are example for schedule 40 of JIS G3456. Customers can also order for other sizes.
 4. For dimensional tolerance, refer to JIS B2203.
 5. T of 125 nominal Diameter is maker's standard.



63Kg/Cm²

JIS B2220-1984(KSB 1503-1999)

WELDING NECK STEEL PIPE FLANGES

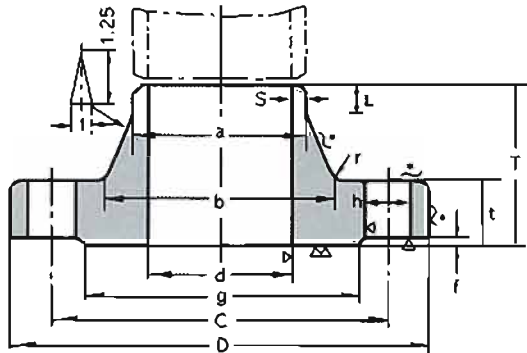

The surface finish shown above is in the case of forging (▽marks: in other cases)

Reference: Beveling

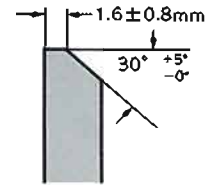

When particularly necessary, customers can order another beveling form the above.

Nominal Diameter of Flange	Outside Diameter of Steel Pipe	Outside Diameter of Flange D	Sectional Dimensions of Flange										Bolt Hole			Nominal Bolt Size	Approx Weight(kg)	
			t	d	a	b	S	T	L	Radius r	f	g	Bolt Circle Diameter C	Number of Bolt Holes	Diameter of Hole h		#80	#160
15	21.7	120	23		21.7	45	3.1	60	10	6	1	55	85	4	19	M16	2.07	2.09
20	27.2	135	25		27.2	50	3.2	62	12	6	1	60	95	4	23	M20	2.80	2.85
25	34.0	140	27		34.0	54	3.8	62	13	6	1	70	100	4	23	M20	3.29	3.33
32	42.7	150	31	To be specified by purchaser.	42.7	64	4.0	66	13	6	2	80	110	4	23	M20	4.12	4.2
40	48.6	175	33		48.6	78	4.2	78	14	6	2	90	130	4	25	M22	6.17	6.31
50	60.5	185	35		60.5	92	4.4	84	16	8	2	105	145	8	23	M20	7.35	7.85
65	76.3	220	39		76.3	114	5.8	96	18	10	2	130	175	8	25	M22	11.85	12.22
80	89.1	230	41		89.1	126	6.1	98	18	10	2	140	185	8	25	M22	13.23	13.82
(90)	101.6	255	42		101.6	140	6.4	126	18	10	2	150	205	8	27	M24	15.2	15.8
100	114.3	270	45		114.3	154	6.8	107	20	10	2	165	220	8	27	M24	19.45	20.65
125	139.8	325	51		(139.8)	(190)	7.5	(128)	24	12	2	200	265	8	33	M30	31.40	34.0
150	165.2	365	55		165.2	224	8.1	142	26	15	2	240	305	12	33	M30	45.0	48.5
200	216.3	425	61		216.3	274	9.4	151	30	15	2	290	360	12	33	M30	63.60	70.7
250	267.4	500	69	267.4	340	10.6	175	38	20	2	355	430	12	39	M36	144.0	-	
300	318.5	560	78	318.5	402	11.8	286	44	23	3	410	485	16	39	M36	154.0	-	
350	355.6	615	82	355.6	438	12.7	301	48	25	3	455	530	16	46	M43	191	-	
400	406.4	680	81	406.4	490	14.6	314	48	25	3	515	590	16	46	M43	247	-	

- REMARKS: 1. Flange of parenthesized nominal diameter had better not be used.
 2. The Flange gasket surface is based on "large raised facing" specified in JIS B2202. If necessary, customers can order for other types of facing.
 3. Size d and Size are example for schedule 40 of JIS G3454 and JIS G3456. Customers can also order for oterh sizes.
 4. For dimensional tolerance, refer to JIS B2203.
 5. The dimension of () are maker's standard.



1K

KS V 7815 JIS F 7805
SLIP-ON FLANGES

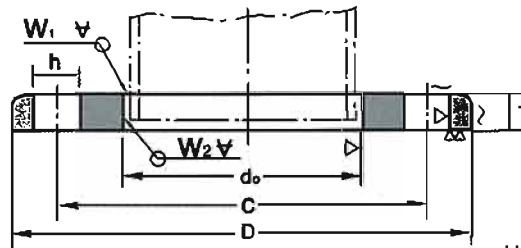

Unit:mm

N/D	PIPE	FLANGE			BOLT HOLE			BOLT (M)	WT (KG)
	O/D(d)	D	I/D(do)	T	C	N	h		
25	34.0	95	34.5	10	75	4	12	M10	0.45
(32)	42.7	115	43.2	12	90	4	15	M12	0.73
40	48.6	120	49.1	12	95	4	15	M12	0.83
50	60.5	130	61.1	14	105	4	15	M12	1.06
65	76.3	155	77.1	14	130	4	15	M12	1.48
80	89.1	180	90.0	14	145	4	19	M16	1.97
100	114.3	200	115.4	16	165	8	19	M16	2.35
125	139.8	235	141.2	16	200	8	19	M16	3.20
150	165.2	265	166.6	16	230	8	19	M16	3.90
200	216.3	320	218.0	16	280	8	23	M20	5.00
250	267.4	385	269.5	16	345	12	23	M20	6.63
300	318.5	430	321.0	16	390	12	23	M20	7.45
360	355.6	480	358.1	16	435	12	25	M22	9.45
400	406.4	540	409.0	16	495	16	25	M22	11.43
450	457.2	605	460.0	16	555	16	25	M22	14.40
500	508.0	655	511.0	16	605	16	25	M22	15.73
(550)	555.8	660	562.0	16	620	16	23	M20	12.00
600	609.6	710	613.0	16	670	16	23	M20	12.12
(650)	660.4	760	664.0	16	720	16	23	M20	12.15
700	711.2	815	715.0	16	775	16	23	M20	14.28
750	762.0	865	766.0	16	825	20	23	M20	14.88
800	812.8	915	817.0	16	875	20	23	M20	15.70
(850)	863.6	965	868.0	16	925	20	23	M20	16.50
900	914.4	1025	919.0	18	980	20	25	M22	21.48
(950)	962.0	1075	967.0	18	1030	20	25	M22	21.97
1000	1016.0	1125	1021.0	18	1080	20	25	M22	23.38
1050	1062.0	1175	1067.0	18	1130	24	25	M22	25.21
1100	1117.6	1225	1122.0	18	1180	24	25	M22	25.16
1150	1162.0	1275	1167.0	18	1230	24	25	M22	26.64
1200	1219.0	1325	1224.0	18	1280	24	25	M22	27.60
1250	1262.0	1375	1267.0	18	1330	28	25	M22	29.72
1300	1312.0	1425	1317.0	18	1380	28	25	M22	30.92
1350	1371.6	1475	1376.0	18	1430	28	25	M22	32.38
1400	1412.0	1525	1417.0	20	1480	28	25	M22	37.02
1450	1462.0	1595	1467.0	20	1540	28	27	M24	46.81
1500	1524.0	1645	1529.0	20	1590	28	27	M24	46.88
1600	1612.0	1745	1617.0	20	1690	28	27	M24	50.54
1700	1712.0	1845	1717.0	20	1790	28	27	M24	53.70
1800	1812.0	1950	1817.0	20	1895	32	27	M24	58.90
1900	1912.0	2050	1917.0	20	1995	32	27	M24	62.18
2000	2012.0	2150	2017.0	20	2095	36	27	M24	65.10
2100	2116.0	2250	2121.0	24	2195	36	27	M24	79.55
2200	2216.0	2350	2221.0	24	2295	40	27	M24	82.94
2300	2316.0	2450	2321.0	24	2395	40	27	M24	86.75
2400	2416.0	2550	2421.0	24	2495	40	27	M24	89.71
2500	2516.0	2650	2521.0	24	2595	48	27	M24	93.52
2600	2616.0	2750	2621.0	24	2695	48	27	M24	97.34

2Kg/Cm²

KS B 1511-1987. JIS B 2220-1977

SLIP-ON FLANGE

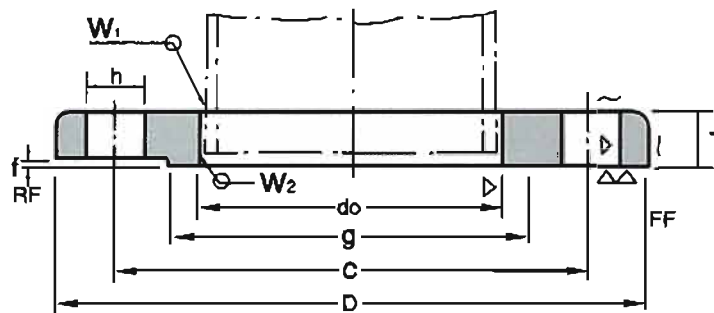

Unit:mm

Nominal Bore of Flange	Outside Diam. of Applicable Pipe	Inside Diam. of Flange do	Sectional Dimensions		Bolt Hole			Nominal Bolt Size
			t	D	C	h	N	
450A	457.2	460	22	605	555	23	16	M20
500A	508.0	511	22	655	605	23	20	M20
550A	558.8	562	24	720	665	25	20	M22
600A	609.6	613	24	770	715	25	20	M22
650A	660.4	664	24	825	770	25	24	M22
700A	711.2	715	24	875	820	25	24	M22
750A	762.0	766	24	945	880	27	24	M24
800A	812.8	817	24	995	930	27	24	M24
(850)A	863.6	868	24	1045	980	27	24	M24
900A	914.4	919	24	1095	1030	27	24	M24
1000A	1016.0	1021	26	1195	1130	27	28	M24
(1100)A	1117.6	1123	26	1305	1240	27	28	M24
1200A	1219.2	1224	26	1420	1350	27	32	M24
1350A	1371.6	1377	26	1575	1505	27	32	M24
1500A	1524.0	1529	28	1730	1660	27	36	M24



5K SET-ON FLANGE JIS B 2220-1999

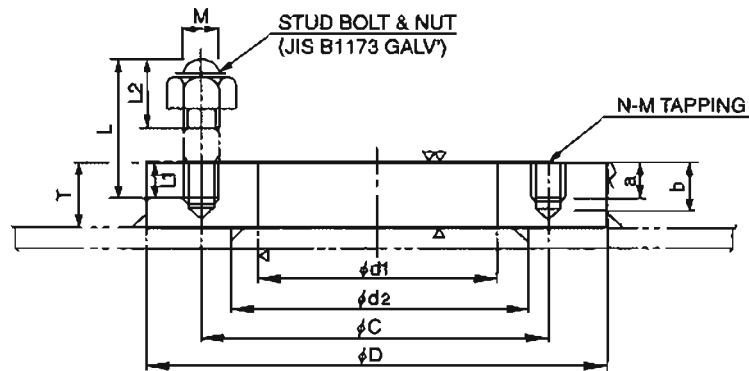

Nominal Broe of Flange	Sectional Dimensions						STUD BOLT					Weight (kg)
	D	C	d1	T	a	b	N	M	L	L2	L1	
10A	75	55	17.8	16	10	12	4	M10	32	CONTINUOUS THREAD		0.47
15A	80	60	22.2	16	10	12	4	M10	32			0.53
20A	85	65	27.7	16	10	12	4	M10	32			0.60
25A	95	75	34.5	16	10	12	4	M10	32			0.72
32A	115	90	43.2	22	12	16	4	M12	40	22	12	1.45
40A	120	95	49.1	22	12	16	4	M12	40	22	12	1.54
50A	130	105	61.1	22	12	16	4	M12	45	22	12	1.70
65A	155	130	77.1	22	12	16	4	M12	45	22	12	2.36
80A	180	145	90.0	26	16	19	4	M16	50	28	16	3.74
100A	200	165	115.4	26	16	19	8	M16	55	28	16	4.01
125A	235	200	141.2	26	16	19	8	M16	55	28	16	5.38
150A	265	230	166.6	26	16	19	8	M16	55	28	16	6.52
200A	320	280	218.0	30	20	23	8	M20	65	36	20	9.66
250A	385	345	269.5	30	20	23	12	M20	65	36	20	13.25
300A	430	390	321.0	30	20	23	12	M20	65	36	20	14.41
350A	480	435	358.1	34	22	25	12	M22	75	40	22	20.55
400A	540	495	409.0	34	22	25	16	M22	75	40	22	24.85
450A	605	555	460.0	34	22	25	16	M22	75	40	22	31.15

10K SET-ON FLANGE JIS B 2220-1999

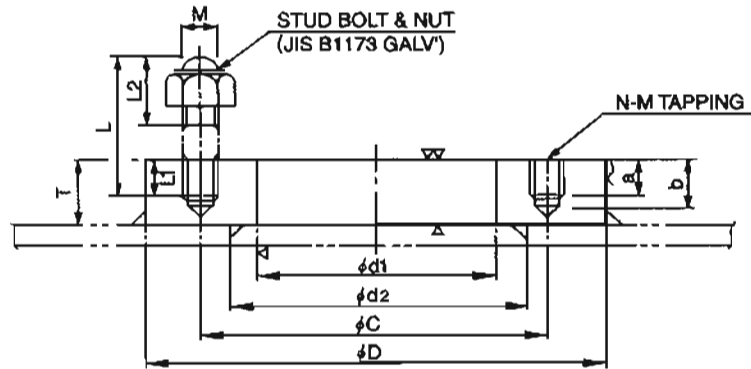

Nominal Broe of Flange	Sectional Dimensions						STUD BOLT					Weight (kg)
	D	C	d1	T	a	b	N	M	L	L2	L1	
10A	90	65	17.8	22	12	16	4	M12	40	22	12	0.97
15A	95	70	22.2	22	12	16	4	M12	40	22	12	1.07
20A	100	75	27.7	22	12	16	4	M12	40	22	12	1.17
25A	125	90	34.5	26	16	19	4	M16	50	28	16	2.27
32A	135	100	43.2	26	16	19	4	M16	50	28	16	2.57
40A	140	105	49.1	26	16	19	4	M16	50	28	16	2.67
50A	155	120	61.1	26	16	19	4	M16	50	28	16	3.07
65A	175	140	77.1	26	16	19	4	M16	55	28	16	3.11
80A	185	150	90.0	26	16	19	8	M16	55	28	16	3.87
100A	210	175	115.4	26	16	19	8	M16	55	28	16	4.67
125A	250	210	141.2	30	20	23	8	M20	65	36	20	7.36
150A	280	240	166.6	30	20	23	8	M20	70	36	20	8.84
200A	330	290	218.0	30	20	23	12	M20	70	36	20	10.64
250A	400	355	269.5	34	22	25	12	M22	75	40	22	17.51
300A	445	400	321.0	34	22	25	16	M22	75	40	22	18.63



KS B2332-1994 & KS D 4308 KS B 2333-1995

Sluice valves for water works flang Butterfly valve for water works flange

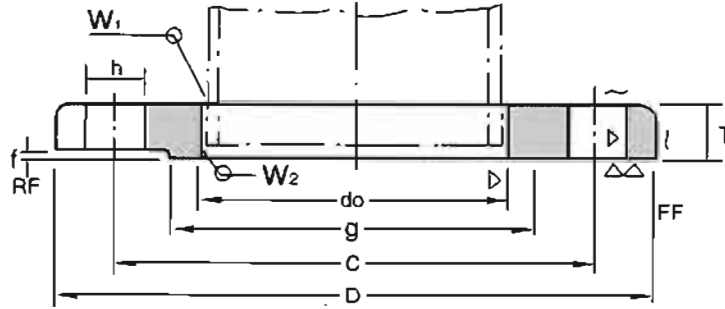

Unit: mm

Nominal Bore of Flange	Inside Diam. of Flange do	Sluice valves for water works flange Sectional Dimensions of Flange								Butterfly valves for water works flange Sectional Dimensions of Flange							
		T	D	C	g	f	Diam. of Bolt		T	D	C	g	f	Diam. of Bolt			
							h	N						h	N		
50A	61.1	16	155	120	100	2	19	4									
80A	80.0	19	200	160	133	3	19	4									
100A	115.4	19	220	180	153	3	19	8									
125A	141.2	19	250	210	183	3	19	8									
150A	166.6	19	285	240	209	3	23	8									
200A	218.0	20	340	295	264	3	23	8	24	340	295	264	3	23	8		
250A	269.5	22	395	350	319	3	23	12	25	395	350	319	3	23	12		
300A	321.0	24	445	400	367	4	23	12	27	445	400	367	4	23	12		
350A	358.1	24	505	460	427	4	23	16	28	505	460	427	4	23	16		
400A	409.0	24	565	515	477	4	28	16	29	565	515	477	4	28	16		
450A	460.0	28	615	565	527	4	28	20	30	615	565	527	4	28	20		
500A	511.0	26	670	620	582	4	28	20	31	670	620	582	4	28	20		
600A	613.0	30	780	725	692	4	31	20	32	780	725	692	4	31	20		
700A	715.0	32	895	840	797	4	31	24	34	895	840	797	4	31	24		
800A	817.0	35	1015	950	904	5	34	24	36	1015	950	904	5	34	24		
900A	919.0	38	1115	1050	1004	5	34	28	38	1115	1050	1004	5	34	28		
1000A	1021.0	40	1230	1180	1111	5	37	28	40	1230	1180	1111	5	37	28		
1100A	1122.0	40	1366	1270	1200	5	37	32	42	1366	1270	1200	5	37	32		
1200A	1224.0	43	1470	1387	1304	5	37	32	44	1470	1387	1304	5	37	32		
1350A	1376.0	45	1642	1552	1462	6	38	36	48	1642	1552	1462	6	38	36		
1500A	1529.0	48	1800	1710	1620	6	38	36	50	1800	1710	1620	6	38	36		
1600A	1617.0								50	1915	1820	1760	6	40	40		
1650A	1682.0								50	1950	1880	1770	6	40	40		
1800A	1817.0								50	2115	2020	1960	6	48	44		
2000A	2017.0								54	2325	2230	2170	6	48	48		



河北海浩

FLANGES WELD ON PIPES DIN 2573.....	019	BLIND FLANGES DIN 2527 PN16.....	028
FLANGES WELD ON PIPES DIN 2576.....	020	BLIND FLANGES DIN 2527 PN25.....	028
FLANGES WELD ON PIPES DIN 2502.....	021	BLIND FLANGES DIN 2527 PN40.....	029
FLANGES WELD ON PIPES DIN 2503.....	022	WELDING NECK FLANGES DIN 2631.....	030
LAPPED FLANGES WITH COLLAR DIN 2642...	024	WELDING NECK FLANGES DIN 2632.....	031
LAPPED FLANGES WITH COLLAR DIN 2655...	025	WELDING NECK FLANGES DIN 2633.....	032
LAPPED FLANGES WITH COLLAR DIN 2656...	025	WELDING NECK FLANGES DIN 2634.....	033
SCREWED PIPE FLANGES DIN2566.....	026	WELDING NECK FLANGES DIN 2635.....	034
BLIND FLANGES DIN 2527 PN6.....	027	WELDING NECK FLANGES DIN 2636.....	035
BLIND FLANGES DIN 2527 PN10.....	027	WELDING NECK FLANGES DIN 2637.....	035



德标
法兰参数系列



FLANGES WELD ON PIPES
Nominal pressure :6kgf/cm²-ND6
DIN 2573

FLANGES
DUZ,BORUYA KAYNAK EDILEN
Anma Basinci:6kgf/cm²-ND6
TS 816/1 (TS ISO 7005-1)

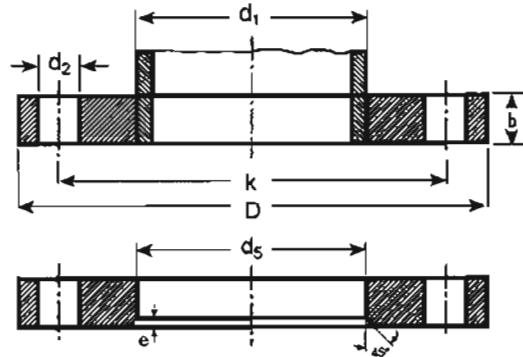

BORU (Pipe)		FLANS (Flange)						CIVATALAR (Bolts)			AGIRLIK (Weight) (7.85 kg/dm ³) kg
DN	d ₁ 1 2	d ₅	D	b	e	k	Sayisi (Each)	Vida (Screw)	d ₂		
10	14	14.5	75	12	5	50	4	M10	11.5	0.363	
	17.2	17.7									
15	20	21	80	12	5	55	4	M10	11.5	0.410	
	21.3	22									
20	25	26	90	14	5	65	4	M10	11.5	0.600	
	26.9	27.6									
25	30	31	100	14	5	75	4	M10	11.5	0.740	
	33.7	34.4									
32	38	39	120	16	5	90	4	M12	14	1.19	
	42.4	43.1									
40	44.5	45.5	130	16	5	100	4	M12	14	1.39	
	48.3	49									
50	57	58.1	140	16	6	110	4	M12	14	1.53	
	60.3	61.1									
65	76.1	77.1	160	16	6	130	4	M12	14	1.89	
80	88.9	90.3	190	18	7	150	4	M16	18	2.98	
100	108	109.6	210	18	7	170	4	M16	18	3.46	
	114.3	115.9									
125	133	134.8	240	20	7	200	8	M16	18	4.60	
	139.7	141.6									
150	159	161.1	265	20	7	225	8	M16	18	5.22	
	168.3	170.5									
200	219.1	221.8	320	22	7	280	8	M16	18	7.15	
250	267	270.2	375	24	7	335	12	M16	18	9.61	
	273	276.2									
300	323.9	327.6	440	24	7	395	12	M20	23	12.6	
350	355.6	359.7	490	26	7	445	12	M20	23	15.6	
	368	372.2									
400	406.4	411	540	28	7	495	16	M20	23	18.4	
	419	423.7									
(450)	457	462.5	595	30	7	550	16	M20	23	21.4	
500	508	513.6	645	30	7	600	20	M20	23	24.6	

FLANGES WELD ON PIPES
 Nominal pressure :10kgf/cm²-ND10
 DIN 2576
 FLANGES
 DUZ,BORUYA KAYNAK EDILEN
 Anma Basincı:10kgf/cm²-ND6
 TS 816/2 (TS ISO 7005-1)

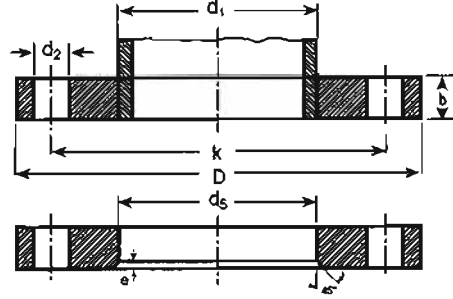

BORU (Pipe)		FLANS (Flange)						CIVATALAR (Bolts)			AĞIRLIK (Weight) (7.85 kg/dm ³) kg
DN	d_1 1 2	d_5	D	b	e	k	Sayı (Each)	Vida (Screw)	d_2		
10	14	14.5	90	14	5	60	4	M12	14	0.613	
	17.2	17.7								0.605	
15	20	21	95	14	5	65	4	M12	14	0.675	
	21.3	22								0.669	
20	25	26	105	16	5	75	4	M12	14	0.749	
	26.9	27.6								0.936	
25	30	31	115	16	5	85	4	M12	14	1.14	
	33.7	34.4								1.11	
32	38	39	140	18	5	100	4	M16	18	1.66	
	42.4	43.1								1.62	
40	44.5	45.5	150	16	5	110	4	M16	18	1.89	
	48.3	49								1.86	
50	57	58.1	165	18	6	125	4	M16	18	2.51	
	60.3	61.1								2.47	
65	76.1	77.1	185	18	6	145	4	M16	18	3.00	
80	88.9	90.3	200	20	7	160	4	M16	18	3.79	
100	108	109.6	220	20	7	180	8	M16	18	4.20	
	114.3	115.9								4.03	
125	133	134.8	250	22	7	210	8	M16	18	5.71	
	139.7	141.6								5.46	
150	159	161.1	285	22	7	240	8	M20	23	6.72	
	168.3	170.5								6.57	
(175)	193.7	196.1	315	24	7	270	8	M20	23	8.45	
200	219.1	221.8	340	24	7	295	8	M20	23	9.31	
250	267	270.2	395	26	7	350	12	M20	23	12.5	
	273	276.2								11.9	
300	323.9	327.6	445	26	7	400	12	M20	23	13.8	
350	355.6	359.7	505	28	7	460	16	M20	23	20.6	
	368	372.2								19.0	
400	406.4	411	565	32	7	515	16	M24	27	27.9	
	419	423.7								25.9	
(450)	457	462.5	615	38	7	565	20	M24	27	35.6	
500	508	513.6	670	38	7	620	20	M24	27	41.1	
600	610	-	816.5	780	40	7	725	20	M27	30	51.87
700	711	-	716	895	40	7	840	24	M27	30	65.79
800	813	-	818	1015	44	7	950	24	M30	33	90.87
900	914	-	920	1115	48	7	1050	28	M30	33	108.41
1000	1016	-	1022	1230	50	7	1160	28	M33	36	133.21
1200	1220	-	1226	1455	54	7	1380	32	M36	39	188.20
1400	1420	-	1426	1675	60	7	1590	36	M39	42	262.14
1600	1620	-	1626	1915	64	7	1820	40	M45	48	367.43
1800	1820	-	1826	2115	70	7	2020	44	M45	48	447.79
2000	2020	-	2026	2325	76	7	2230	48	M45	48	577.71
2200	2220	-	2226	2550	82	7	2440	52	M52	56	699.88
2400	2420	-	2426	2760	88	7	2650	56	M52	56	844.49
2600	2620	-	2626	2960	94	7	2850	60	M52	56	972.23
2800	2820	-	2826	3180	100	7	3070	64	M52	56	1187.1
3000	3020	-	3026	3405	106	7	3290	68	M52	56	

*Duz boruya kaynakli flanslarınND 16-ND 25 -ND 40 olarak imalati yapılmaktadır.



**DIN2502
PN16**

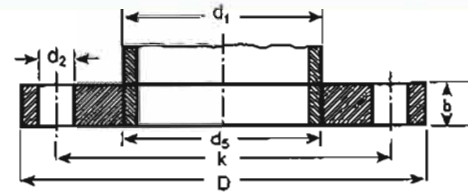

TUBO			BRIDA		TORNILLOS			PESO UNIDAD (7,85kg/dm ³) kg. m		
DN	ISO	d ₁ DIN	d ₅	D	b	k	CANT. ROSCA		d ₂	
10 a 175	Los diámetros nominales de 10 a 175, son iguales que la tabla DIN 2576									
10		14	14.5	90	14	60	4	M12	14	0.613
	17.2		17.7							0.605
15		20	21	95	14	65	4	M12	14	0.675
	21.3		22							0.669
20		25	26	105	16	75	4	M12	14	0.749
	26.9		27.6							0.936
25		30	31	115	16	85	4	M12	14	1.14
	33.7		34.4							1.11
32		38	39	140	16	100	4	M16	18	1.66
	42.4		43.1							1.62
40		44.5	45.5	150	16	110	4	M16	18	1.89
	48.3		49							1.86
50		57	58.1	165	18	125	4	M16	18	2.51
	60.3		61.1							2.47
65	76.1		77.1	185	18	145	4	M16	18	3.00
80	88.9	-	90.3	200	20	160	8	M16	18	3.79
100		108	109.6	220	20	180	8	M16	18	4.20
	114.3		115.9							4.03
125		133	134.8	250	22	210	8	M16	18	5.71
	139.7		141.6							5.46
150		159	161.1	285	22	240	8	M20	23	6.72
	168.3		170.5							6.57
175	193.7		196.1	315	24	270	8	M20	23	8.45
200	219.1	216	221.8	340	24	295	12	M20	23	9.2
250		267	270.2	405	26	355	12	M24	27	13.4
	273	-	276.2							
300	323.9	318	327.6	460	28	410	12	M24	27	17.4
350	355.6	-	359.7	520	30	470	16	M24	27	26.6
	-	368	372.2							
400	406.4	-	411	580	32	525	16	M27	30	30.9
	-	419	423.7							
500	508	521	513.6	715	38	650	20	M30	33	54.0
600	610	622	616.5	840	42	770	20	M33	36	77.58
700	711	720	716	910	44	840	24	M33	36	77.13
800	813	820	818	1.025	50	950	24	M36	39	106.35
900	914	920	920	1.125	54	1.050	28	M36	39	125.39
1.000	1.016	1020	1.022	1.255	60	1.170	28	M39	42	177.99
1.200	1.220	-	1.226	1.485	68	1.390	32	M45	48	263.46
1.400	1.420	-	1.426	1.685	74	1.590	36	M45	48	329.77
1.600	1.620	-	1.626	1.930	82	1.820	40	M52	56	483.11
1.800	1.820	-	1.826	2.130	88	2.020	44	M52	56	577.63
2.000	3.020	-	2.026	2.345	94	2.230	48	M56	62	720.85

DIN2503 PN25

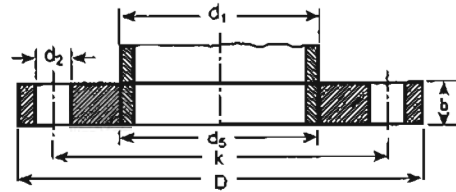

TUBO		BRIDA				TORNILLOS		PESO UNIDAD (7,85kg/dm ³) kg.		
DN	ISO	d ₁ DIN	d _s	D	b	k	CANT. ROSCA		d ₂	
10 a 150	Los diámetros nominales de 10 a 150, son iguales que la tabla de Presion Nominal 40									
15		20	21	95	16	65	4	M12	14	0.77
	21.3		22							
20		25	26	105	18	75	4	M12	14	1
	26.9		27.6							
25		30	31	115	18	85	4	M12	14	1.28
	33.7		34.4							
32		38	39	140	18	100	4	M16	18	1.87
	42.4		43.1							
40		44.5	45.5	150	18	110	4	M16	18	2.13
	48.3		49							
50		57	58.1	165	20	125	4	M16	18	2.79
	60.3		61.1							
65		76.1	77.1	185	22	145	8	M16	18	3.48
80		88.9	90.3	200	24	160	8	M16	18	4.35
100		108	109.6	235	24	190	8	M20	22	5.78
	114.3		115.9							
125		133	134.8	270	26	220	8	M24	26	7.87
	139.7		141.6							
150		159	161.1	300	28	250	8	M24	26	10.1
	168.3		170.5							
(175)		-	196.1	330	28	280	12	M24	26	11.0
200		-	221.8	360	30	310	12	M24	26	13.6
250		267	270.2	425	32	370	12	M27	30	19.4
	273		276.2							
300		-	327.6	485	34	430	16	M27	30	25.0
350		-	359.7	555	38	490	16	M30	33	38.2
	355.6		372.2							
400		-	411	620	40	550	16	M33	36	48.8
	406.4		423.7							
500		-	513.6	730	44	660	20	M33	36	67.2
600		-	616.5	845	50	770	20	M36	39	93.57
700		-	716	960	52	875	24	M39	42	117.53
800		-	818	1085	56	990	24	M45	48	156.31
900		-	920	1185	62	1090	28	M45	48	188.57
1000		-	1022	1320	68	1210	28	M52	56	255.79
1200		-	1226	1530	76	1420	32	M52	56	345.56
1400		-	1426	1755	86	1640	36	M56	62	481.53
1600		-	1626	1975	96	1860	40	M56	62	652.83
1800		-	1826	2185	104	2070	44	M64	70	800.15



**DIN2503
PN40**

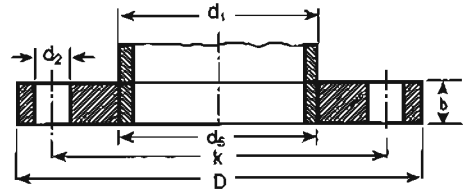

TUBO			BRIDA				TORNILLOS			PESO UNIDAD (7,85kg/dm ³) kg. ≈
DN	ISO	d ₁ DIN	d ₅	D	b	k	CANT.	ROSCA	d ₂	
15		20	21	95	16	65	4	M12	14	0.77
	21.3		22							
20		25	26	105	18	75	4	M12	14	1
	26.9		27.6							
25		30	31	115	18	85	4	M12	14	1.28
	33.7		34.4							
32		38	39	140	18	100	4	M16	18	1.87
	42.4		43.1							
40		44.5	45.5	150	18	110	4	M16	18	2.13
	48.3		49							
50		57	58.1	165	20	125	4	M16	18	2.79
	60.3		61.1							
65	76.1		77.1	185	22	145	8	M16	18	3.48
80	88.9		90.3	200	24	160	8	M16	18	4.35
100		108	109.6	235	24	190	8	M20	22	5.78
	114.3		115.9							
125		133	134.8	270	26	220	8	M24	26	7.87
	139.7		141.6							
150		159	161.1	300	28	250	8	M24	26	10.1
	168.3		170.5							
200	219.1		221.8	375	34	320	12	M27	30	17.4
250		267	270.2	450	38	385	12	M30	33	27.6
	273		276.2							
300	323.9		327.6	515	42	450	16	M30	33	37.8
350			359.7	580	46	510	16	M33	36	53.4
	355.6	368	372.2							
400			411	660	50	585	16	M36	39	75.4
	406.4	419	423.7							
500	508		513.6	755	52	670	20	M39	42	88.3

LAPPED FLANGES WITH COLLAR
 Nominal Pressure :10kgf/cm²-ND10
 DIN 2642
 FLANGES
 BORULARICIN,DESTEKLIGEVSEK
 Anma Basinci:10kgf/cm²-ND10
 TS 814/2 (TS ISO 7005-1)

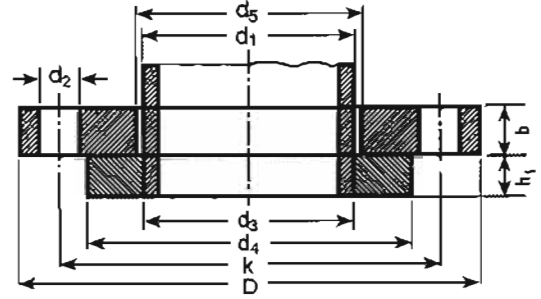

BORU (Pipe)		FLANS (Flange)			CIVATALAR (Bolts)		DESTEK (Beam)				AGIRLIK(Weight) 7.85 kg/dm ³		
DN	d_1	D	d_5	b	k	Sayisi (Each)	Vida (Screw)	d_2	d_3	d_4	h_1	Flans (flange)kg	Destek (Beam)kg
10	14	90	16	14	60	4	M12	14	17.7	40	10	0.599	0.087
	17.2		19										
15	20	95	22	14	65	4	M12	14	22	45	10	0.689	0.105
	21.3		24										
20	25	105	28	14	75	4	M12	14	27.6	58	12	0.806	0.203
	26.9		30										
25	30	115	33	16	85	4	M12	14	34.4	68	12	1.11	0.276
	33.7		36										
32	38	140	42	16	100	4	M16	18	43.1	78	12	1.64	0.343
	42.4		46										
40	44.5	150	50	16	110	4	M16	18	49	88	12	1.86	0.426
	48.3		54										
50	57	165	62	16	125	4	M16	18	61.1	102	14	2.20	0.618
	60.3		65										
65	76.1	185	81	16	145	4	M16	18	77.1	122	14	2.62	0.786
80	88.9	200	94	18	160	4/8	M16	18	90.3	138	16	3.32	1.10
100	108	220	113	18	180	8	M16	18	115.9	158	16	3.67	1.31
	114.3		119										
125	133	250	138	18	210	8	M16	18	141.6	188	18	4.54	1.96
	139.7		145										
150	168.3	285	173	18	240	8	M20	22	170.5	212	18	5.60	2.18
200	219.1	340	225	20	295	8	M20	22	221.8	268	20	7.46	3.10
250	273	395	279	22	350	12	M20	22	276.2	320	22	10.3	4.22
300	323.9	445	329	26	400	12	M20	22	327.6	370	22	14.0	4.85
350	355.6	505	362	28	460	16	M20	22	372.2	430	22	18.5	6.71
400	406.4	565	413	32	515	16	M24	26	423.7	482	24	25.0	8.28
(450)	457	615	467	38	565	20	M24	26	462.5	532	24	30.6	9.3
500	508	670	517	38	620	20	M24	26	513.6	585	26	37.0	11.5
600	610	780	618	44	725	20	M27	30	616.6	685	26	56.3	15.6
700	711	895	721	50	840	24	M27	30	718.6	800	28	80.4	23.2
800	813	1015	824	56	950	24	M30	33	821.5	905	30	113.2	29.2

LAPPED FLANGES WITH COLLAR
Nominal Pressure :25kgf/cm²-ND25
DIN 2655

FLANGES
BORULARICIN,DESTEKLIGEVSİK
Anma Basıncı:25kgf/cm²-ND25
TS 814/4 (TS ISO 7005-1)

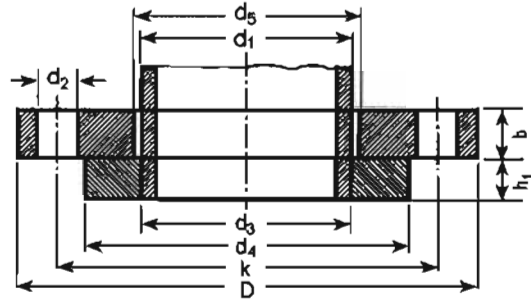

BORU (Pipe)		FLANS (Flange)				CIVATALAR (Bolts)		DESTEK (Beam)				AGIRLIK(Weight) 7.85 kg/dm ³	
DN	d ₁	D	d ₅	b	k	Sayısı (Each)	Vida (Screw)	d ₂	d ₃	d ₄	h ₁	Flans (flange) kg	Destek (Beam) kg
10	17.2	Değerler DIN 2656 (40 kgf/cm ²) den alınmalıdır											
150	168.3												
200	219.1	360	225	26	310	12	M24	26	221.8	278	24	11.7	4.53
250	273	425	279	30	370	12	M27	30	276.2	335	26	17.9	6.56
300	323.9	485	329	34	430	16	M27	30	327.6	395	28	24.7	8.80
350	355.6	555	362	38	490	16	M30	33	359.2	450	32	37.38	13.2
400	406.4	620	414	42	550	16	M33	36	411	505	34	50	16.5
500	508	730	517	50	660	20	M33	36	513.6	615	38	73.89	25.3

LAPPED FLANGES WITH COLLAR
Nominal Pressure :40kgf/cm²-ND40
DIN 2656

FLANGES
BORULARICIN,DESTEKLİ GEVSİK
Anma Basıncı:40kgf/cm²-ND40
TS 814/5 (TS ISO 7005-1)

BORU (Pipe)		FLANS (Flange)				CIVATALAR (Bolts)		DESTEK (Beam)				AGIRLIK(Weight) 7.85 kg/dm ³	
DN	d ₁	D	d ₅	b	k	Sayısı (Each)	Vida (Screw)	d ₂	d ₃	d ₄	h ₁	Flans (flange)kg	Destek (Beam)kg
10	17.2	90	19	16	60	4	M12	14	17.7	40	12	0.696	0.104
15	21.3	95	24	16	65	4	M12	14	22	45	12	0.773	0.126
20	26.9	105	30	16	75	4	M12	14	27.6	58	14	0.934	0.236
25	33.7	115	36	18	85	4	M12	14	34.4	68	14	1.26	0.321
32	42.4	140	46	18	100	4	M16	18	43.1	78	14	1.85	0.401
40	48.3	150	54	18	110	4	M16	18	49	83	14	2.10	0.498
50	60.3	165	65	20	125	4	M16	18	61.1	102	16	2.75	0.706
65	76.1	185	81	20	145	8	M16	18	77.1	122	16	3.11	0.898
80	88.9	200	94	22	160	8	M16	18	90.3	138	18	3.88	1.23
100	114.3	235	119	22	190	8	M20	22	115.9	162	20	5.23	1.80
125	139.7	270	145	24	220	8	M24	26	141.6	188	22	7.23	2.40
150	168.3	300	173	24	250	8	M24	26	170.5	218	22	8.60	3.02
200	219.1	375	225	30	320	12	M27	30	221.8	285	26	15.2	5.54
250	273	450	279	36	385	12	M30	33	276.2	345	30	25.7	8.83
300	323.9	515	329	40	450	16	M30	33	327.6	410	34	34.42	14.0
350	355.6	580	362	46	510	16	M33	36	359.2	465	38	52.36	18.9
400	406.4	660	414	50	585	16	M36	39	411	535	42	74.2	28.4

SCREWED PIPE FLANGES

Nominal Pressure :10 and 16kgf/cm²-ND10-ND16

DIN 2566

FLANGES

BORULARICIN,VIDALI

Anma Basinci:10ve 16kgf/cm²-ND10-ND16

TS 813 (TS ISO 7005-1)

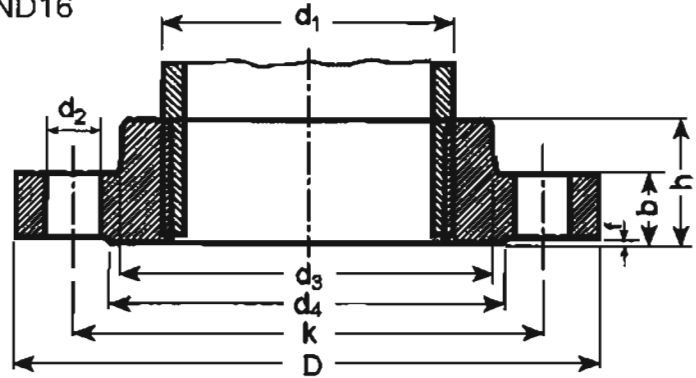

BORU (Pipe)		FLANS (Flange)						BOYUN (Neck)	ALINCIKINTISI (Raised face)			CIVATALAR (Bolts)			FLANSAGIRLIGI (Flange weight) (7.85 kg/dm ³) kg
DN	d_1	Boru Vidasi (Whitwort)	D	b	k	h	d_3	d_4	f	Sayisi Each	Vida Screw	d_2			
6	10.2	R1/8"	75	12	50	18	20	32	2	4	M10	11	0.326		
8	13.5	R1/4"	80	12	55	18	25	38	2	4	M10	11	0.380		
10	17.2	R3/8"	90	14	60	20	30	40	2	4	M12	14	0.544		
15	21.3	R1/2"	95	14	65	20	35	45	2	4	M12	14	0.613		
20	26.9	R3/4"	105	16	75	24	45	58	2	4	M12	14	0.910		
25	33.7	R1"	115	16	85	24	52	68	2	4	M12	14	1.20		
32	42.4	R1 1/4"	140	16	100	26	60	78	2	4	M16	18	1.60		
40	48.3	R1 1/2"	150	16	110	26	70	88	3	4	M16	18	1.78		
50	60.3	R2"	165	18	125	28	85	102	3	4	M16	18	2.43		
65	76.1	R2 1/2"	185	18	145	32	105	122	3	4	M16	18	3.18		
80	88.9	R3"	200	20	160	34	118	138	3	4/8	M16	18	4.12		
100	114.3	R4"	220	20	180	38	140	158	3	8	M16	18	4.47		
125	139.7	R5"	250	22	210	40	168	188	3	8	M16	18	6.13		
150	165.1	R6"	285	22	240	44	195	212	3	8	M20	23	7.92		

*Siparse gore galvanizli olarak imal edilebilir.

BLIND FLANGES

Nominal Pressure :6kgf/cm²-ND6

DIN 2527

KOR FLANS

Anma Basıncı:6kgf/cm²-ND6

(TS ISO 7005-1)

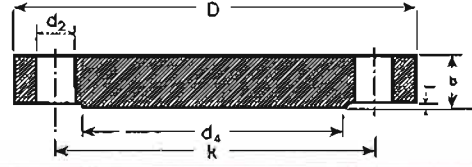

BÖRU (Pipe) DN	D	b	k	ALINCIKINTISI (Raised face)		DELİKLER (Drilling)			AGIRLIK (Weight) kg
				d ₁	f	Sayısı (Each)	Vida (Screw)	d ₂	
10	75	12	50	35	2	4	M10	11.5	0.38
15	80	12	55	40	2	4	M10	11.5	0.44
20	90	14	65	50	2	4	M10	11.5	0.654
25	100	14	75	60	2	4	M10	11.5	0.82
32	120	14	90	70	2	4	M12	14	1.176
40	130	14	100	80	3	4	M12	14	1.392
50	140	14	110	90	3	4	M12	14	1.63
65	160	14	130	110	3	4	M12	14	2.48
80	190	18	150	128	3	4	M16	18	3.49
100	210	16	170	148	3	4	M16	18	4.86
125	240	18	200	178	3	8	M16	18	6.28
150	265	18	225	202	3	8	M16	18	7.75
175	295	20	255	230	3	8	M16	18	10.7
200	320	20	280	258	3	8	M16	18	12.7
250	375	22	335	312	3	12	M16	18	19.0
300	440	22	395	365	4	12	M20	23	26.3
350	490	22	445	415	4	12	M20	23	32.9
400	540	22	495	455	4	16	M20	23	40.2
500	645	24	600	570	4	20	M20	23	63.2
600	755	28	705	670	5	20	M24	27	96.07
700	860	30	810	775	5	24	M24	27	133.8
800	975	32	920	880	5	24	M27	30	183.29
900	1075	36	1020	980	5	24	M27	30	251.7
1000	1175	42	1120	1080	5	28	M27	30	350.98

BLIND FLANGES

Nominal Pressure :10kgf/cm²-ND10

KOR FLANS

Anma Basıncı:10kgf/cm²-ND10

(TS ISO 7005-1)

BORU (Pipe) DN	D	b	k	ALINCIKINTISI (Raised face)		DELİKLER (Drilling)			AGIRLIK (Weight) kg
				d ₁	f	Sayısı (Each)	Vida (Screw)	d ₂	
10 175	10 ile 175 arasındaki değerler ND 16 'dan alınmalıdır.								
200	340	24	295	268	3	8	M20	23	16.9
250	395	26	350	320	3	12	M20	23	24.7
300	445	26	400	370	4	12	M20	23	31.9
350	505	26	460	430	4	16	M20	23	41.9
400	565	26	515	482	4	16	M24	27	51.2
500	670	28	620	585	4	20	M24	27	77.8
600	780	30	725	685	5	20	M27	30	109.2
700	895	32	840	800	5	24	M27	30	153.77
800	1015	36	950	905	5	24	M30	33	222.86
900	1115	40	1050	1005	5	24	M30	33	299.08
1000	1230	46	1160	1110	5	28	M33	36	418.78

BLIND FLANGES

Nominal Pressure :16kgf/cm²-ND16

DIN 2527

KOR FLANS

Anma Basıncı:16kgf/cm²-ND16

(TS ISO 7005-1)

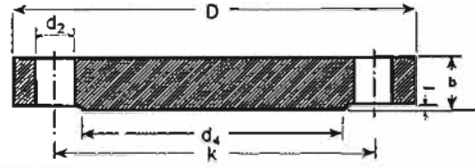

BORU (Pipe) DN	D	b	k	ALINCIKINTISI (Raised face)		DELİKLER (Drilling)			AGIRLIK (Weight) kg
				d ₄	f	Sayısı (Each)	Vida (Screw)	d ₂	
10	90	14	60	40	2	4	M12	14	0.63
15	95	14	65	45	2	4	M12	14	0.72
20	105	16	75	58	2	4	M12	14	1.01
25	115	16	85	68	2	4	M12	14	1.23
32	140	16	100	78	2	4	M16	18	1.80
40	150	16	110	88	3	4	M16	18	2.09
50	165	18	125	102	3	4	M16	18	2.88
65	185	18	145	122	3	4	M16	18	3.66
80	200	20	160	138	3	8	M16	18	4.77
100	220	20	180	158	3	8	M16	18	5.65
125	250	22	210	188	3	8	M16	18	8.42
160	285	22	240	212	3	8	M20	23	10.4
(175)	315	24	270	242	3	8	M20	23	14.0
200	340	24	295	268	3	12	M20	23	16.1
250	405	28	355	320	3	12	M24	27	24.9
300	460	28	410	378	4	12	M24	27	35.1
350	520	30	470	438	4	16	M24	27	47.8
400	580	32	526	490	4	16	M27	30	63.5
500	715	34	650	610	4	20	M30	33	102
600	840	36	770	725	5	20	M33	36	149.7
700	910	36	840	795	5	24	M33	36	173.7
800	1025	38	950	900	5	24	M36	39	235.5
900	1126	40	1050	1000	5	28	M36	39	298.8
1000	1255	42	1170	1115	5	28	M39	42	390.7
1200	1485	48	1390	1330	5	32	M45	48	624.8
1400	1685	52	1590	1530	5	36	M45	48	872.6
1600	1930	58	1820	1750	5	40	M52	56	1275.1
1800	2130	62	2020	1950	5	44	M52	56	1661.9
2000	2345	66	2230	2150	5	48	M56	62	2142.1

BLIND FLANGES

Nominal Pressure :25kgf/cm²-ND25

DIN 2527

KOR FLANS

Anma Basıncı:25kgf/cm²-ND25

(TS ISO 7005-1)

BORU (Pipe) DN	D	b	k	ALINCIKINTISI (Raised face)		DELİKLER (Drilling)			AGIRLIK (Weight) kg
				d ₄	f	Sayısı (Each)	Vida (Screw)	d ₂	
10 150	Anma basıncı 40 kgf/cm ² olan ölçülerden alınmalıdır.								
(175)	330	28	280	248	3	12	M24	27	17.6
200	360	30	310	278	3	12	M24	27	22.7
250	425	32	370	335	3	12	M27	30	34.5
300	485	34	430	395	4	16	M27	30	47.3
350	555	38	490	450	4	16	M30	33	69.3
400	620	40	550	505	4	16	M33	36	91.5
500	730	44	660	615	4	20	M33	36	141
600	845	48	770	720	5	20	M36	39	202.3
700	960	50	875	820	5	24	M39	42	271.05
800	1085	54	990	930	5	24	M45	48	373.52
900	1185	58	1090	1030	5	28	M45	48	479.07
1000	1320	62	1210	1140	5	28	M52	56	632.47

BLIND FLANGE

Nominal Pressure : 40kgf/cm²-ND40

DIN 2527

KOR FLANS

Anma Basıncı: 40kgf/cm²-ND40

(TS ISO 7005-1)

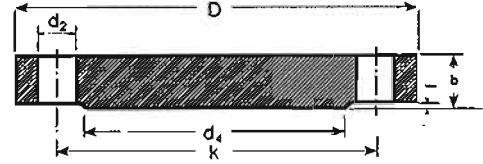

BORU (Pipe) DN	D	b	k	ALINCIKINTISI (Raised face)		DELIKLER (Drilling)			AGIRLIK (Weight) kg
				d ₄	f	Sayısı (Each)	Vida (Screw)	d ₂	
10	90	16	60	40	2	4	M12	14	0.722
15	95	16	65	45	2	4	M12	14	0.813
20	105	18	75	58	2	4	M12	14	1.137
25	115	18	85	68	2	4	M12	14	1.382
32	140	18	100	78	2	4	M16	18	2.033
40	150	18	110	88	3	4	M16	18	2.355
50	165	20	125	102	3	4	M16	18	3.2
65	185	22	145	122	3	8	M16	18	4.33
80	200	24	160	138	3	8	M16	18	5.94
100	235	24	190	162	3	8	M20	23	7.64
125	270	26	220	188	3	8	M24	27	11.0
150	300	28	250	218	3	8	M24	27	14.7
(175)	350	32	295	260	3	12	M27	30	22.4
200	375	34	320	285	3	12	M27	30	27.6
250	450	38	385	345	3	12	M30	33	44.5
300	515	42	450	410	4	16	M30	33	64.3
350	580	46	510	460	4	16	M33	36	90.8
400	660	50	585	535	4	16	M36	39	129
500	755	56	670	615	4	20	M39	42	175
600	890	62	795	733	5	20	M45	48	285.17
700	995	64	900	838	5	24	M45	48	368.83
800	1140	70	1030	960	5	24	M52	56	528.39
900	1250	78	1140	1070	5	28	M52	56	690.99
1000	1360	84	1250	1180	5	28	M52	56	912.42

*Kor Flanslar ND 64 ve DN100 normlarında imalatı yapılmaktadır

WELDING NECK FLANGES

Nominal Pressure :6kgf/cm²-ND6

DIN 2631

FLANSLAR

BORULAR ICIN, BOYUNLARI KAYNAKLI

Anma Basinci:6kgf/cm²-ND6

TS 811/2

(TS ISO 7005-1)

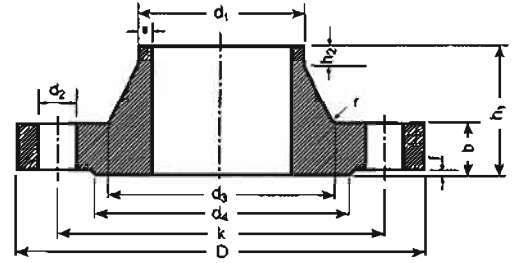

BORU (Pipe)		FLANS (Flange)				BOYUN (Neck)				ALINCIKINTEIE (Raised face)		CIVATALAR (Bolts)			FLANS AGIRLEK (Weight) (7.85 kg/dm ³) kg
DN	d ₁ ISO/DIN	D	b	k	h ₁	d ₃	s	r	h ₂	d ₄	f	Sayisi (Each)	Vida (Screw)	d ₅	
15	20 21.3	80	12	55	30	28 30	2	4	6	40	2	4		11	0.392
20	25 26.9	90	14	65	32	35 38	2.3	4	6	50	2	4		11	0.592
25	30 33.7	100	14	75	35	40 42	2.6	4	6	60	2	4		11	0.747
32	38 42.4	120	14	90	35	50 55	2.6	6	8	70	2	4		14	1.05
40	44.5 48.3	130	14	100	38	58 62	2.6	6	7	80	3	4		14	1.18
50	57 60.3	140	14	110	38	70 74	2.9	6	8	90	3	4		14	1.34
65	76.1	160	14	130	38	88	2.9	6	9	110	3	4		14	1.67
80	88.9	190	16	150	42	102	3.2	8	10	128	3	4		18	2.71
100	108 114.3	210	16	170	45	122 130	3.6	8	10	148	3	4		18	3.24
125	133 139.7	240	18	200	48	148 155	4	8	10	178	3	8		18	4.49
150	159 168.3	265	18	225	48	172 184	4.5	10	12	202	3	8		18	5.15
200	219.1	320	20	280	55	236	5.9	10	15	258	3	8		18	7.78
250	267 273	375	22	335	60	282 290	6.3	12	15	312	3	12		18	10.8
300	323.9	440	22	395	62	342	7.1	12	15	365	4	12		22	14
350	355.6 368	490	22	445	62	385	7.1	12	15	415	4	12		22	18.7
400	406.4 419	540	22	495	65	438	7.1	12	15	455	4	16		22	19
500	508	645	24	600	68	538	7.1	12	15	570	4	20		22	28.6
600	610	755	24	705	70	640	7.1	12	16	670	5	20	M24	26	31.5
700	711	860	24	810	70	740	7.1	12	16	775	5	24	M24	26	37.4
800	813	975	24	920	70	842	7.1	12	16	880	5	24	M27	30	46.1
900	914	1075	26	1020	70	942	7.1	12	18	980	5	24	M27	30	55.6
1000	1016	1175	26	1120	70	1045	7.1	16	18	1080	5	28	M27	30	61.9
1200	1220	1405	28	1340	90	1248	8	16	20	1295	5	32	M30	33	100
1400	1420	1630	32	1560	90	1452	8	16	20	1510	5	36	M33	36	149
1600	1620	1830	34	1760	90	1655	9	16	20	1710	5	40	M33	36	180
1800	1820	2045	36	1970	100	1855	10	16	20	1920	5	44	M36	39	225
2000	2020	2265	38	2180	110	2058	11	16	25	2125	6	48	M39	42	295
2200	2220	2475	42	2390	115	2260	12	18	25	2335	6	52	M39	42	361
2400	2420	2685	44	2600	125	2462	13	18	25	2545	6	56	M39	42	415
2600	2620	2905	46	2810	130	2665	14	18	25	2750	6	60	M45	48	530
2800	2820	3115	48	3020	135	2865	15	18	30	2960	6	64	M45	48	643
3000	3020	3315	50	3220	140	3068	16	18	30	3160	6	68	M45	48	777
3200	3220	3525	54	3430	150	3272	16	20	30	3370	6	72	M45	48	851
3400	3420	3735	56	3640	160	3475	18	20	35	3580	6	76	M45	48	993
3600	3620	3970	60	3860	165	3678	18	20	35	3790	6	80	M52	58	1001



DIN 10Bar

DIN 2632 Welding Neck Flange

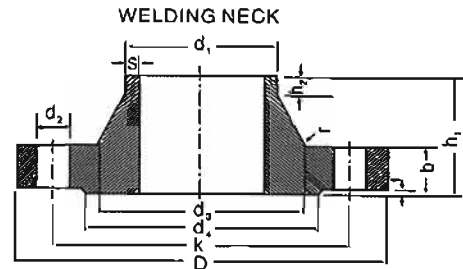

BORE		COMMON DIMENSION			HUB					RAISED FACE		DRILLING		Approx. Weight(kg)
DN	d ₁	D	b	k	h ₁	d ₂	s	r	h ₂	d ₄	f	Number of Bolt	d ₃	DIN 2632
10	14 17.2	90	14	60	35	25 28	1.8	4	6	40	2	4	14	0.58
15	20 21.3	95	14	65	35	30 32	2	4	6	45	2	4	14	0.648
20	25 26.9	105	16	75	38	38 40	2.3	4	6	58	2	4	14	0.952
25	30 33.7	115	16	85	38	42 45	2.6	4	6	68	2	4	14	1.14
32	38 42.4	140	16	100	40	52 56	2.6	6	6	78	2	4	18	1.69
40	44.5 48.3	150	16	110	42	60 64	2.6	6	7	88	3	4	18	1.86
50	57 60.3	165	18	125	45	72 75	2.9	6	8	102	3	4	18	2.53
65	76.1	185	18	145	45	90	2.9	6	10	122	3	4	18	3.06
80	88.9	200	20	160	50	105	3.2	8	10	138	3	8	18	3.7
100	108 114.3	220	20	180	52	125 131	3.6	8	12	158	3	8	18	4.62
125	133 139.7	250	22	210	55	150 156	4	8	12	188	3	8	18	6.3
150	159 168.3	285	22	240	55	175 184	4.5	10	12	212	3	8	22	7.75
175	193.7	315	24	270	60	210	5.4	10	12	242	3	8	22	9.85
200	219.1	340	24	295	62	235	5.9	10	16	268	3	8	22	11.3
250	267 273	395	26	350	68	285 292	6.3	12	16	320	3	12	22	14.7
300	323.9	445	26	400	68	344	7.1	12	16	370	4	12	22	17.4
350	355.6 368	505	26	460	68	395	7.1	12	16	430	4	16	22	21.6
400	406.4 419	565	26	515	72	440	7.1	12	16	482	4	16	26	26.2
500	508	670	28	620	75	542	7.1	12	16	585	4	20	26	38.1
600	610	780	28	725	80	642	7.1	12	18	685	5	20	30	44.6
700	711	895	30	840	80	745	8	12	18	800	5	24	30	62.4
800	813	1015	32	950	90	850	8	12	18	905	5	24	33	84.1
900	914	1115	34	1050	95	950	10	12	20	1005	5	28	33	98.5
1000	1016	1230	34	1160	95	1052	10	16	20	1110	5	28	36	115
1200	1220	1455	38	1380	115	1255	11	16	25	1330	5	32	39	182
1400	1420	1675	42	1590	120	1460	12	16	25	1535	5	36	42	248
1600	1620	1915	46	1820	130	1665	14	16	25	1760	5	40	48	347
1800	1820	2115	50	2020	140	1868	15	16	30	1960	5	44	48	430
2000	2020	2325	54	2230	150	2072	18	16	30	2170	5	48	48	539
2200	2220	2550	58	2440	160	2275	18	18	35	2370	6	52	56	658
2400	2420	2760	62	2650	170	2478	20	18	35	2570	6	56	56	825
2600	2620	2960	66	2850	180	2680	22	18	40	2780	6	60	56	979
2800	2820	3180	70	3070	190	2882	22	18	40	3000	6	64	56	1156
3000	3020	3405	75	3290	200	3085	24	18	45	3210	6	68	62	1420

DIN 16Bar

DIN 2633 Welding Neck Flange

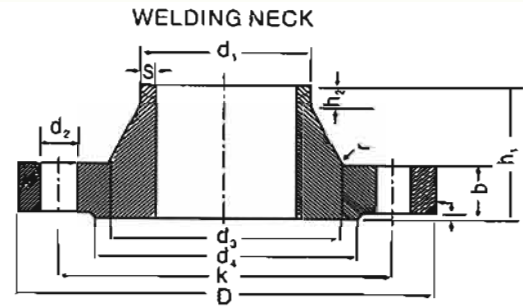

BORE		COMMON DIMENSION			HUB					RAISED FACE		DRILLING		Approx. Weight(kg)
DN	d_1	D	b	k	h_1	d_3	s	r	h_2	d_4	f	Number of Bolt	d_2	DIN 2633
10	14 17.2	80	14	60	35	25 28	1.8	4	6	40	2	4	14	0.58
15	20 21.3	95	14	65	35	30 32	2	4	6	45	2	4	14	0.648
20	25 26.9	105	16	75	38	38 40	2.3	4	6	58	2	4	14	0.952
25	30 33.7	115	16	85	38	42 45	2.6	4	6	68	2	4	14	1.14
32	38 42.4	140	18	100	40	52 58	2.6	6	6	78	2	4	18	1.69
40	44.5 48.3	150	18	110	42	60 64	2.6	6	7	88	3	4	18	1.86
50	57 60.3	165	18	125	45	72 75	2.9	6	8	102	3	4	18	2.53
65	76.1	185	18	145	45	90	2.9	6	10	122	3	4	18	3.08
80	88.9	200	20	160	50	105	3.2	8	10	138	3	8	18	3.7
100	108 114.3	220	20	180	52	125 131	3.6	8	12	158	3	8	18	4.62
125	133 139.7	250	22	210	55	150 156	4	8	12	188	3	8	18	6.3
150	159 168.3	285	22	240	55	175 184	4.5	10	12	212	3	8	22	7.75
175	193.7	315	24	270	60	210	5.4	10	12	242	3	8	22	9.85
200	219.1	340	24	295	62	235	5.9	10	16	268	3	12	22	11
250	267 273	405	26	355	70	285 292	6.3	12	16	320	3	12	26	15.6
300	323.9	460	28	410	78	344	7.1	12	16	378	4	12	26	22
350	355.6 368	520	30	470	82	390	8	12	16	438	4	16	26	28.8
400	406.4 419	580	32	525	85	445	8	12	16	490	4	16	30	36.3
500	508	715	34	650	90	548	8	12	16	610	4	20	33	61
600	610	840	36	770	95	652	8.8	12	18	725	5	20	36	75.4
700	711	910	36	840	100	755	8.8	12	18	795	5	24	36	77
800	813	1025	38	950	105	855	10	12	20	900	5	24	39	101
900	914	1125	40	1050	110	955	10	12	20	1000	5	28	39	122
1000	1016	1255	42	1170	120	1058	10	16	22	1115	5	28	42	162
1200	1220	1485	48	1390	130	1262	12.5	16	30	1330	5	32	48	243
1400	1420	1685	52	1590	145	1465	14.2	16	30	1530	5	36	48	323
1600	1620	1930	58	1820	160	1668	16	16	35	1750	5	40	56	479
1800	1820	2130	62	2020	170	1870	17.5	16	35	1950	5	44	56	599
2000	2020	2345	66	2230	180	2072	20	16	40	2150	5	48	62	719



DIN 25Bar

DIN 2634 Welding Neck Flange

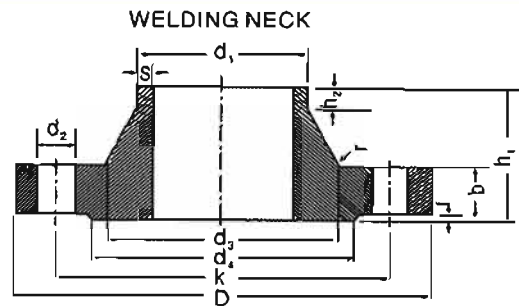

BORE		COMMON DIMENSION			HUB					RAISED FACE		DRILLING		Approx. Weight(kg)
DN	d ₁	D	b	k	h ₁	d ₃	s	r	h ₂	d ₄	f	Number of Bolt	d ₂	DIN 2634
10	14 17.2	90	16	60	35	25 28	1.8	4	6	40	2	4	14	0.661
15	20 21.3	95	16	65	38	30 32	2	4	6	45	2	4	14	0.746
20	25 26.9	105	18	75	40	38 40	2.3	4	6	58	2	4	14	1.06
25	30 33.7	115	18	85	40	42 46	2.6	4	6	68	2	4	14	1.29
32	38 42.4	140	18	100	42	52 56	2.6	6	6	78	2	4	18	1.88
40	44.5 48.3	150	18	110	45	60 64	2.6	6	7	88	3	4	18	2.33
50	57 60.3	165	20	125	48	72 75	2.9	6	8	102	3	4	18	2.82
65	76.1	185	22	145	52	90	2.9	6	10	122	3	8	18	3.74
80	88.9	200	24	160	58	105	3.2	8	12	138	3	8	18	4.75
100	108 114.3	235	24	190	65	128 134	3.6	8	12	162	3	8	22	6.52
125	133 139.7	270	26	220	68	155 162	4	8	12	188	3	8	26	9.07
150	159 168.3	300	28	250	75	182 192	4.5	10	12	218	3	8	26	11.8
175	191 193.7	330	28	280	75	215 218	5.6	10	15	248	3	12	26	13.4
200	216 219.1	360	30	310	80	240 244	6.3	10	16	278	3	12	26	17
250	267 273	425	32	370	88	292 298	7.1	12	18	335	3	12	30	24.4
300	318 323.9	485	34	430	92	345 352	8	12	18	395	4	16	30	31.2
350	355.6 368	555	38	490	100	398	8	12	20	450	4	16	33	47.2 44.2
400	406.4 419	620	40	550	110	452	8.8	12	20	505	4	16	36	61.7 57.9
500	508	730	44	660	125	558	10	12	20	615	4	20	36	89.6
600	610	845	46	770	125	660	11	12	20	720	5	20	39	104
700	711	960	46	875	125	760	12.5	12	20	820	5	24	42	136
800	813	1085	50	990	135	865	14.2	12	22	930	5	24	48	186
900	914	1185	54	1080	145	968	16	12	24	1030	5	28	48	236
1000	1016	1320	58	1210	155	1070	17.5	16	24	1140	5	28	56	307

WELDING NICK FLANGES

Nominal Pressure :40kgf/cm²-ND40
DIN 2635

FLANSLAR

BORULAR ICIN, BOYUNLARI KAYNAKLI

Anma Basinci:40kgf/cm²-ND40

TS 811/6 (TS ISO 7005-1)

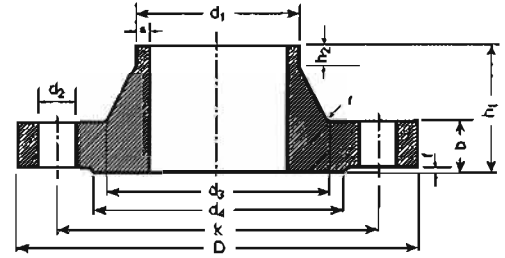

BORU (Pipe)		FLANS (Flange)				BOYUN (Neck)				ALIN ÇIKINTISI (Raised face)		CIVATALAR (Bolts)			FLANS AĞIRLIĞI (Flange Weight) (7.85 kg/dm ³) kg
DN	d ₁ ISODIN	D	b	k	h ₁	d ₃	s	r	h ₂	d ₄	f	Sayısı Each	Vida Screw	d ₂	
10	14	90	16	60	35	25	1.8	4	6	40	2	4	M12	14	0.661
	17.2					28									
15	20	95	16	65	38	30	2	4	6	45	2	4	M12	14	0.746
	21.3					32									
20	25	105	18	75	40	38	2.3	4	6	58	2	4	M12	14	1.06
	26.9					40									
25	30	115	18	85	40	42	2.6	4	6	68	2	4	M12	14	1.29
	33.7					46									
32	38	140	18	100	42	52	2.6	6	6	78	2	4	M16	18	1.88
	42.4					56									
40	44.5	150	18	110	45	60	2.6	6	7	88	3	4	M16	18	2.33
	48.3					64									
50	57	165	20	125	48	72	2.9	6	8	102	3	4	M16	18	2.82
	60.3					75									
65	76.1	185	22	145	52	90	2.9	6	10	122	3	8	M16	18	3.74
80	88.9	200	24	160	58	105	3.2	8	12	138	3	8	M16	18	4.75
100	108	235	24	190	65	128	3.6	8	12	162	3	8	M20	23	6.52
	114.3					134									
125	133	270	26	220	68	155	4	8	12	188	3	8	M24	27	9.07
	139.7					162									
150	159	300	28	250	75	182	4.5	10	12	218	3	8	M24	27	11.8
	168.3					192									
175	191	350	32	295	82	215	5.6	10	15	260	3	12	M27	30	18.2
	193.7					218									
200	216	375	34	320	88	240	6.3	10	16	285	3	12	M27	30	21.5
	219.1					244									
250	267	450	38	385	105	298	7.1	12	18	345	3	12	M30	33	34.9
	273					306									
300	318	515	42	450	115	352	8	12	18	410	4	16	M30	33	49.7
	323.9					362									
350	355.6	580	46	510	125	408	8.8	12	20	465	4	16	M33	36	68.1
	368														
400	406.4	660	50	585	135	462	11	12	20	535	4	16	M36	39	96.5
	419														
500	508	755	52	670	140	562	14.2	12	20	615	4	20	M39	42	117
	521														

WELDING NECK FLANGES

Nominal Pressure:64kgf/cm²-ND64

DIN2636

FLANSLAR

BORULARICIN,BOYUNLARI KAYNAKLI

Anma Basinc1:64kgf/cm²-ND64

TS 811/7 (TS ISO 7005-1)

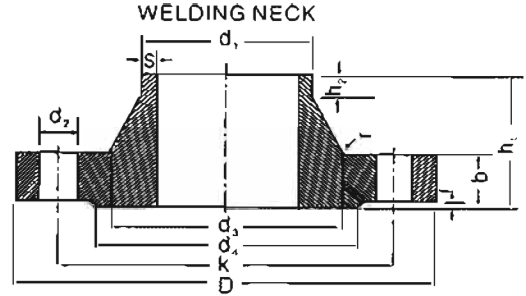

BORE (Pipe)		FLANS (Flange)				BOYUN (Neck)				ALIN ÇIKINTISI (Raised face)		CLVATALAE (Bolts)			FLANS AĞIRLIĞI (Flange Weight) (7.85kg/dm ³) kg
DN	d ₁ ISO/DIN	D	b	k	h ₁	d ₃	s	r	h ₂	d ₄	f	Sayısı (Each)	Vida Screw	d ₂	
10	17.2	Değerler DIN 2637 (100kgf/cm ²) ' den alın malidir.													
40	48.3														
50	60.3	180	26	135	62	82	2.9	6	10	102	3	4	M20	22	4.55
65	76.1	205	26	160	68	98	3.2	6	12	122	3	8	M20	22	5.73
80	88.9	215	28	170	72	112	3.6	8	12	138	3	8	M20	22	6.69
100	114.3	250	30	200	78	138	4.0	8	12	162	3	8	M24	26	9.66
125	139.7	295	34	240	88	168	4.5	8	12	188	3	8	M27	30	15.1
150	168.3	345	36	280	95	202	5.6	10	12	218	3	8	M30	33	21.9
175	193.7	375	40	310	105	228	6.3	10	16	260	3	12	M30	33	23.7
200	219.1	415	42	345	110	256	7.1	10	16	285	3	12	M33	36	34.9
250	273	470	46	400	125	316	8.8	12	18	345	3	12	M33	36	49.6
300	323.9	530	52	460	140	372	11	12	18	410	4	16	M33	36	68.7
350	355.6	600	56	525	150	420	12.5	12	20	465	4	16	M36	39	94.6
400	406.4	670	60	585	160	475	14.2	12	20	535	4	16	M39	42	124

WELDING NECK FLANGES

Nominal Pressure:100kgf/cm²-ND100

DIN2637

FLANSLAR

BORULAR ICIN, BOYUNLARI KAYNAKLI

Anm Basinc1:100kgf/cm²-DN100

TS 811/8 (TS ISO 7005-1)

BORE (Pipe)		FLANS (Flange)				BOYUN (Neck)				ALIN ÇIKINTISI (Raised face)		CLVATALAE (Bolts)			FLANS AĞIRLIĞI (Flange Weight) (7.85kg/dm ³) kg
DN	d ₁ ISO/DIN	D	b	k	h ₁	d ₃	s	r	h ₂	d ₄	f	Sayısı (Each)	Vida Screw	d ₂	
10	17.2	100	20	70	45	32	1.8	4	6	40	2	4	M12	14	1.09
15	21.3	105	20	75	45	34	2.0	4	6	45	2	4	M12	14	1.19
25	33.7	140	24	100	58	52	2.6	4	8	68	2	4	M16	18	2.66
40	48.3	170	26	125	62	70	2.9	6	10	88	3	4	M20	22	4.09
50	60.3	195	28	145	68	90	3.2	6	10	102	3	4	M24	26	5.98
65	76.1	220	30	170	76	108	3.6	6	12	122	3	8	M24	26	7.91
80	88.9	230	32	180	78	120	4.0	8	12	138	3	8	M24	26	8.95
100	114.3	265	36	210	90	150	5.0	8	12	162	3	8	M27	30	13.7
125	139.7	315	40	250	105	180	6.3	8	12	188	3	8	M30	33	22.7
150	168.3	355	44	290	115	210	7.1	10	12	218	3	12	M30	33	30.2
175	193.7	385	48	320	127	245	8.8	10	16	260	3	12	M30	33	38.9
200	219.1	430	52	360	130	278	10.0	10	16	285	3	12	M33	36	52.8
250	273	505	60	430	157	340	12.5	12	18	345	3	12	M36	39	81.4
300	323.9	585	68	500	170	400	14.2	12	18	410	4	16	M39	42	122
350	355.6	655	74	560	189	460	16.0	12	20	485	4	16	M45	48	165

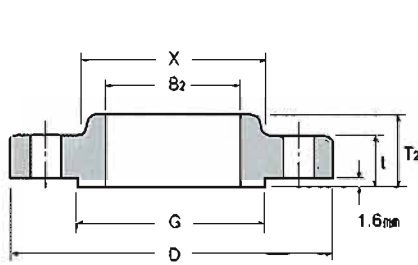

SLIP-ON

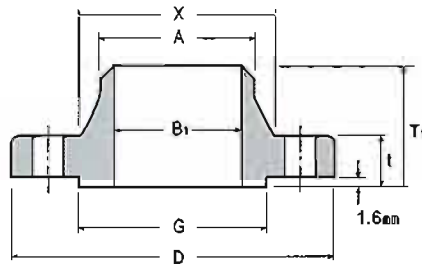

WELDING NECK

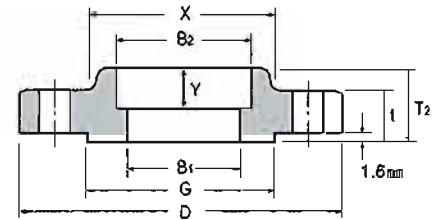

SOCKET WELDING

CLASS 150 FLANGES

ANSI B16.5 FORGED FLANGES

Unit:mm

Nominal Pipe Size	Outside Diam.	Diam. at Base of Hub	O.D of Raised Face	Thick-ness	BORE			LENGTH THRU HUB			Diam. of Hub at Bevel	Radius of Fillet	Thread Length
					Welding Neck Socket Welding	Slip-on Socket Welding	Lap Joint	Welding Neck	Slip-on Threaded Socket Welding	Lap Joint			
					B1	B2	B3	T1	T2	T3			
1/2	88.9	30.2	35.1	11.2	15.7	22.4	22.9	47.8	15.7	15.7	21.3	3.0	15.7
3/4	98.6	38.1	42.9	12.7	20.8	27.7	28.2	52.3	15.7	15.7	26.7	3.0	15.7
1	108	49.3	50.8	14.2	26.7	34.5	35.1	55.6	17.5	17.5	33.5	3.0	17.5
1 1/4	117.3	58.7	63.5	15.7	35.1	43.2	43.7	57.2	20.6	20.6	42.2	4.8	20.6
1 1/2	127	65.0	73.2	17.5	40.9	49.5	50.0	62.0	22.4	22.4	48.3	6.4	22.4
2	152.4	77.7	91.9	19.1	52.6	62.0	62.5	63.5	25.4	25.4	60.5	7.9	25.4
2 1/2	177.8	90.4	104.6	22.4	62.7	74.7	75.4	69.9	28.4	28.4	73.2	7.9	28.4
3	190.5	108.0	127.0	23.9	78.0	90.7	91.4	69.9	30.2	30.2	88.9	9.7	30.2
3 1/2	215.9	122.2	139.7	23.9	90.2	103.4	104.1	71.4	31.8	31.8	101.6	9.7	31.8
4	228.6	134.9	157.2	23.9	102.4	116.1	116.8	76.2	33.3	33.3	114.3	11.2	33.3
5	254	163.6	185.7	23.9	128.3	143.8	144.5	88.9	36.6	36.6	141.2	11.2	36.6
6	279.4	192.0	215.9	25.4	154.2	170.7	171.5	88.9	39.6	39.6	168.4	12.7	39.6
8	342.9	246.1	269.7	28.4	202.7	221.5	222.3	101.6	44.5	44.5	219.2	12.7	44.5
10	406.4	304.8	323.9	30.2	254.5	276.4	277.4	101.6	49.3	49.3	273.1	12.7	49.3
12	482.6	365.3	381.0	31.8	304.8	327.2	328.2	114.3	55.6	55.6	323.9	12.7	55.6
14	533.4	400.1	412.8	35.1	336.6	359.2	360.2	127.0	57.2	79.2	355.6	12.7	57.2
16	596.9	457.2	469.9	36.6	387.4	410.5	411.2	127.0	63.5	87.4	406.4	12.7	63.5
18	635	505.0	533.4	39.6	438.2	461.8	462.3	139.7	68.3	96.8	457.2	12.7	68.3
20	698.5	558.8	584.2	42.9	489.0	513.1	514.4	144.5	73.2	103.1	508.0	12.7	73.2
24	812.8	663.4	692.2	47.8	590.6	616.0	616.0	152.4	82.6	111.3	609.6	12.7	82.6

Notes:

- (1) For the 'Bore'(B1) other than Standard Wall Thickness, refer to page 83.
- (2) Class 150 flanges except Lap Joint will be furnished with 0.06" (1.6mm) raised face, which is included in 'Thickness' (t) and 'Length through Hub' (T1), (T2).
- (3) For Slip-on, Threaded, Socket Welding and Lap Joint Flanges, the hubs can be shaped either vertical from base to top or tapered within the limits of 7 degrees.

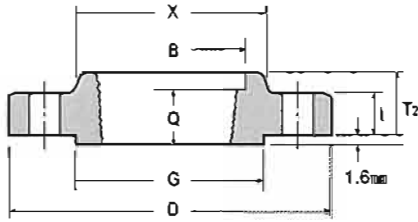

THREADED

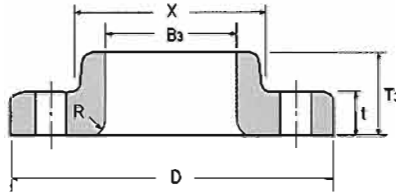

LAP JOINT

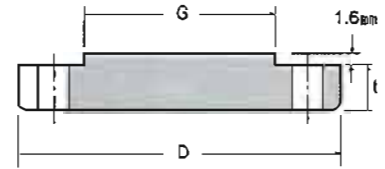

BLIND

CLASS 150 FLANGES

ANSI B16.5 FORGED FLANGES

Unit:mm

Nominal Pipe Size	Depth of Socket Y	DRILLING			BOLTING				APPROXIMATE WEIGHT						
		Bolt Circle Diam	Number of Holes	Diam of Holes	Diam of Bolts (inch)	Machine Bolt Length		Stud Bolt Length	Welding Neck			Slip-on and Threaded	Lap Joint	Blind	Socket Welding
						Raised Face	Ring Joint		SCH40	SCH80	SCH160				
1/2	9.7	60.5	4	15.7	1/2	50.8	57.2	--	0.60	0.60	0.60	0.47	0.51	0.47	0.47
3/4	11.2	69.9	4	15.7	1/2	50.8	63.5	--	0.90	0.90	0.90	0.58	0.64	0.63	0.59
1	12.7	79.2	4	15.7	1/2	57.2	63.5	76.2	1.14	1.18	1.24	0.86	0.93	0.94	0.87
1 1/4	14.2	88.9	4	15.7	1/2	57.2	69.9	82.6	1.41	1.48	1.54	1.08	1.16	1.23	1.11
1 1/2	15.7	98.6	4	15.7	1/2	63.5	69.9	82.6	1.81	1.90	2.01	1.41	1.51	1.62	1.45
2	17.5	120.7	4	19.1	5/8	69.9	82.6	95.3	2.72	2.84	3.07	2.26	2.38	2.64	2.33
2 1/2	19.1	139.7	4	19.1	5/8	76.2	88.9	101.6	4.45	4.70	4.98	3.43	3.6	4.07	3.55
3	20.6	152.4	4	19.1	5/8	76.2	88.9	101.6	5.22	5.54	5.90	3.87	4.04	4.92	4.02
3 1/2	22.4	177.8	8	19.1	5/8	76.2	88.9	101.6	6.40	6.76	7.46	5.20	5.24	5.90	5.24
4	23.9	190.5	8	19.1	5/8	76.2	88.9	101.6	7.49	7.96	8.90	5.75	5.96	7.41	5.99
5	23.9	215.9	8	22.4	3/4	82.6	95.3	108.0	9.53	10.54	12.04	6.26	6.44	8.76	6.68
6	26.9	241.3	8	22.4	3/4	82.6	101.6	114.3	11.80	13.12	15.11	7.38	7.65	11.40	8.60
8	31.8	298.5	8	22.4	3/4	88.9	108.0	120.7	19.10	21.34	25.84	12.36	12.66	20.10	13.60
10	33.3	362.0	12	25.4	7/8	101.6	114.3	127.0	24.50	28.85	35.74	17.10	17.4	29.39	19.50
12	39.6	431.8	12	25.4	7/8	101.6	120.7	133.4	39.90	46.80	58.01	27.68	28.3	43.80	29.10
14	41.4	476.3	12	28.4	1	114.3	133.4	146.1	51.80	62.58	77.60	35.2	41.5	59.42	40.90
16	44.5	539.8	16	28.4	1	114.3	133.4	146.1	64.50	79.42	98.82	45.5	52.98	77.40	47.17
18	49.3	577.9	16	31.8	1 1/8	127.0	146.1	158.8	74.90	97.63	124.32	49.71	59	94.8	54.43
20	54.1	635.0	20	31.8	1 1/8	139.7	158.8	171.5	89.40	120.44	154.18	66.5	72.12	123.4	70.31
24	63.5	749.3	20	35.1	1 1/4	152.4	171.5	184.2	121.70	169.37	223.92	90.5	99.42	188.24	95.25

(4) Blind Flanges may be made with the same hub as that used for Slip-on Flanges or without hub.

(5) The gasket surface and backside (bearing surface for bolting) are made parallel within 1 degree. To accomplish parallelism, spot facing is carried out according to MSS SP-9, without reducing thickness(t).

(6) Depth of Socket (Y) is covered by ANSI B16.5 only in sizes through 3 inch, over 3 inch is at the manufacture's option.

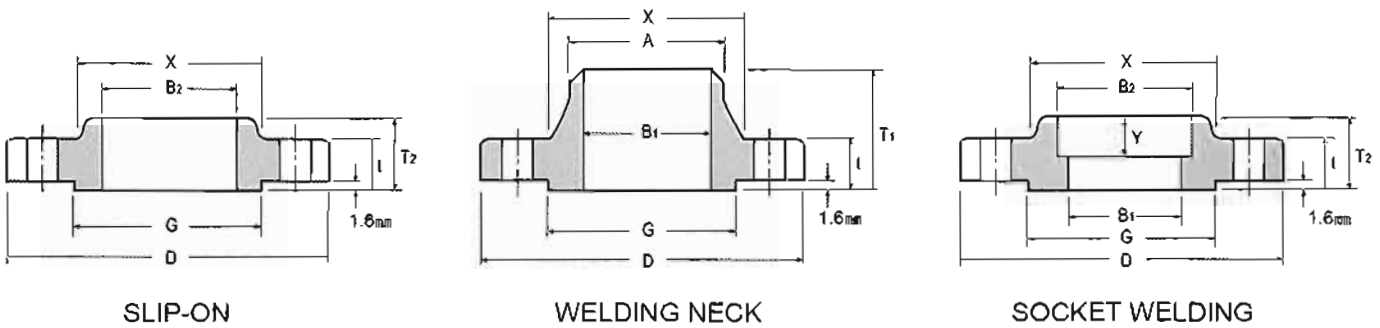

CLASS 300 FLANGES

ANSI B16.5 FORGED FLANGES

Unit:mm

Nominal Pipe Size	Outside Diam. D	Diam. at Base of Hub X	O.D of Raised Face G	Thick-ness t	BORE				LENGTH THRU HUB			Diam. of Hub at Bevel A	Radius of Fillet R	Thread Length Q
					Welding Neck Socket Welding B1	Slip-on Socket Welding B2	Lap Joint B3	Counter Bore Min. Threaded Min. B	Welding Neck T1	Slip-on Threaded Socket Welding T2	Lap Joint T3			
1/2	95.3	38.1	35.1	14.2	15.7	22.4	22.9	23.6	52.3	22.4	22.4	21.3	3.0	15.7
3/4	117.3	47.8	42.9	15.7	20.8	27.7	28.2	29.0	57.2	25.4	25.4	26.7	3.0	15.7
1	124	53.8	50.8	17.5	26.7	34.5	35.1	35.8	62.0	26.9	26.9	33.5	3.0	17.5
1 1/4	133.4	63.5	63.5	19.1	35.1	43.2	43.7	44.5	65.0	26.9	26.9	42.2	4.8	20.6
1 1/2	155.4	69.9	73.2	20.6	40.9	49.5	50.0	50.5	68.3	30.2	30.2	48.3	6.4	22.4
2	165.1	84.1	91.9	22.4	52.6	62.0	62.5	63.5	69.9	33.3	33.3	60.5	7.9	28.4
2 1/2	190.5	100.1	104.6	25.4	62.7	74.7	75.4	76.2	76.2	38.1	38.1	73.2	7.9	31.8
3	209.6	117.3	127.0	28.4	78.0	90.7	91.4	92.2	79.2	42.9	42.9	88.9	9.7	31.8
3 1/2	228.6	133.4	139.7	30.2	90.2	103.4	104.1	104.9	81.0	44.5	44.5	101.6	9.7	36.6
4	254	146.1	157.2	31.8	102.4	116.1	116.8	117.6	85.9	47.8	47.8	114.3	11.2	36.6
5	279.4	177.8	185.7	35.1	128.3	143.8	144.5	144.5	98.6	50.8	50.8	141.2	11.2	42.9
6	317.5	206.2	215.9	36.6	154.2	170.7	171.5	171.5	98.6	52.3	52.3	168.4	12.7	46.0
8	381	260.4	269.7	41.1	202.7	221.5	222.3	222.3	111.3	62.0	62.0	219.2	12.7	50.8
10	444.5	320.5	323.9	47.8	254.5	276.4	277.4	276.4	117.3	66.5	95.3	273.1	12.7	55.6
12	520.7	374.7	381.0	50.8	304.8	327.2	328.2	328.7	130.0	73.2	101.6	323.9	12.7	60.5
14	584.2	425.5	412.8	53.8	336.6	359.2	360.2	360.4	142.7	76.2	111.3	355.6	12.7	63.5
16	647.7	482.6	469.9	57.2	387.4	410.5	411.2	411.2	146.1	82.6	120.7	406.4	12.7	68.3
18	711.2	533.4	533.4	60.5	438.2	461.8	462.3	462.0	158.8	88.9	130.0	457.2	12.7	69.9
20	774.7	587.2	584.2	63.5	489.0	513.1	514.4	512.8	162.1	95.3	139.7	508.0	12.7	73.2
24	914.4	701.5	692.2	69.9	590.6	616.0	616.0	614.4	168.1	106.4	152.4	609.6	12.7	82.6

Notes:

- (1) For the 'Bore'(B1) other than Standard Wall Thickness, refer to page 83.
- (2) Class 300 flanges except Lap Joint will be furnished with 0.06" (1.6mm) raised face, which is included in 'Thickness' (t) and 'Length through Hub' (T1), (T2).
- (3) For Slip-on, Threaded, Socket Welding and Lap Joint Flanges, the hubs can be shaped either vertical from base to top or tapered within the limits of 7 degrees.

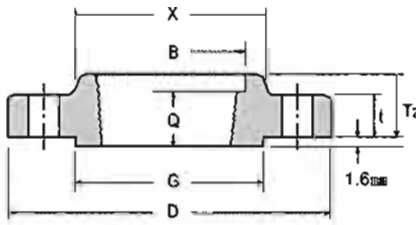

THREADED

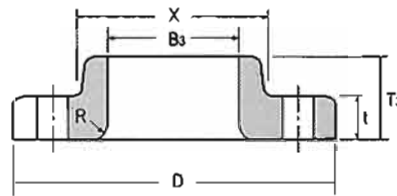

LAP JOINT

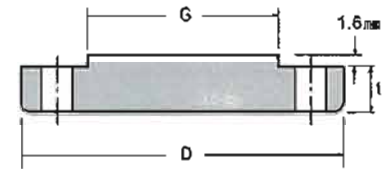

BLIND

CLASS 300 FLANGES

ANSI B16.5 FORGED FLANGES

Unit:mm

Nominal Pipe Size	Depth of Socket Y	DRILLING			BOLTING			APPROXIMATE WEIGHT							
		Bolt Circle Diam	Number of Holes	Diam of Holes	Diam of Bolts (inch)	Stud Bolt Length			Welding Neck			Slip-on and Threaded	Lap Joint	Blind	Socket Welding
						Machine Bolt Length	Raised Face	Ring Joint	SCH40	SCH80	SCH160				
1/2	9.7	66.5	4	15.7	1/2	57.2	63.5	76.2	0.91	0.91	0.91	0.63	0.63	0.63	0.63
3/4	11.2	82.6	4	19.1	5/8	63.5	76.2	88.9	1.36	1.36	1.36	1.16	1.16	1.16	1.19
1	12.7	88.9	4	19.1	5/8	63.5	76.2	88.9	1.82	1.87	1.93	1.39	1.39	1.42	1.44
1 1/4	14.2	98.6	4	19.1	5/8	69.9	82.6	95.3	2.27	2.35	2.41	1.75	1.75	1.88	1.75
1 1/2	15.7	114.3	4	22.4	3/4	76.2	88.9	101.6	3.18	3.28	3.40	2.53	2.53	2.68	2.62
2	17.5	127.0	8	19.1	5/8	76.2	88.9	101.6	3.36	3.49	3.75	2.90	2.91	3.22	2.94
2 1/2	19.1	149.4	8	22.4	3/4	82.6	101.6	114.3	5.45	5.72	6.02	4.25	4.25	4.80	4.49
3	20.6	168.1	8	22.4	3/4	88.9	108.0	120.7	7.32	7.52	8.94	5.92	5.94	6.89	6.2
3 1/2	22.4	184.2	8	22.4	3/4	95.3	108.0	127.0	8.93	9.31	10.10	7.72	7.74	9.53	
4	23.9	200.2	8	22.4	3/4	95.3	114.3	127.0	12.10	12.62	13.69	10.13	10.15	11.2	
5	23.9	235.0	8	22.4	3/4	108.0	120.7	133.4	16.30	17.42	19.08	12.58	12.6	15.96	
6	26.9	269.7	12	22.4	3/4	108.0	120.7	139.7	20.40	21.86	24.07	16.04	16.05	21.40	
8	31.8	330.2	12	25.4	7/8	120.7	139.7	152.4	31.30	33.75	38.69	24.5	24.53	34.6	
10	33.3	387.4	16	28.4	1	139.7	158.8	171.5	45.40	50.43	58.38	34.16	39.92	53.50	
12	39.6	450.9	16	31.8	1 1/8	146.1	171.5	184.2	64.50	72.35	85.10	51.26	58.7	78.9	
14	41.4	514.4	20	31.8	1 1/8	158.8	177.8	190.5	93.50	105.61	122.49	72.12	83.46	107.5	
16	44.5	571.5	20	35.1	1 1/4	165.1	190.5	203.2	113.10	130.25	152.56	90.4	106.14	139.25	
18	49.3	628.7	24	35.1	1 1/4	171.5	196.9	209.6	138.90	164.74	195.07	109	133.95	176.9	
20	54.1	685.8	24	35.1	1 1/4	184.2	203.2	222.3	167.70	202.32	240.17	136	157.65	223.17	
24	63.5	812.8	24	41.1	1 1/2	203.2	228.6	254.0	238.68	288.15	348.28	204	240.4	342	

- (4) Blind Flanges may be made with the same hub as that used for Slip-on Flanges or without hub.
- (5) The gasket surface and backside (bearing surface for bolting) are made parallel within 1 degree. To accomplish parallelism, spot facing is carried out according to MSS SP-9, without reducing thickness(t).
- (6) Depth of Socket (Y) is covered by ANSI B16.5 only in sizes through 3 inch, over 3 inch is at the manufacture's option.

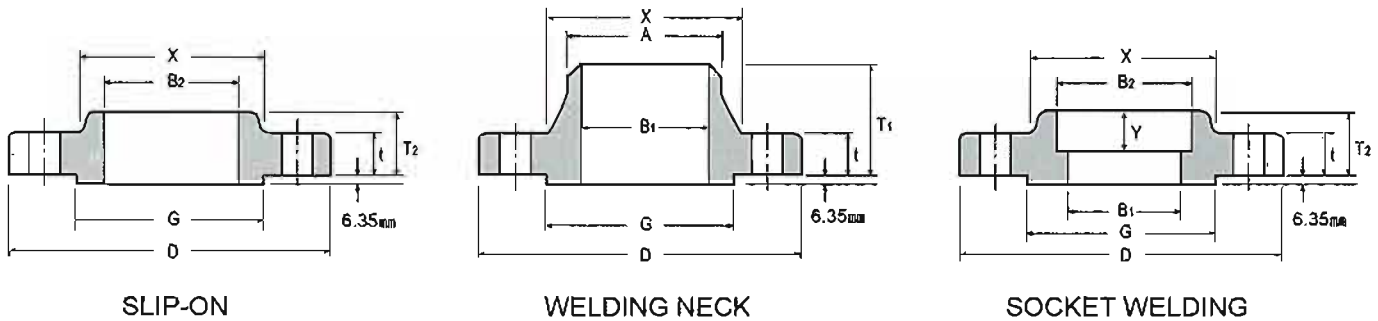

CLASS 600 FLANGES

ANSI B16.5 FORGED FLANGES

Unit:mm

Nominal Pipe Size	Outside Diam. D	Diam. at Base of Hub X	O.D of Raised Face G	Thick-ness t	BORE				LENGTH THRU HUB			Diam. of Hub at Bevel A	Radius of Fillet R	Thread Length Q
					Welding Neck Socket Welding	Slip-on Socket Welding	Lap Joint	Counter Bore Min.	Welding Neck	Slip-on Threaded Socket Welding	Lap Joint			
					B1	B2	B3	B	T1	T2	T3			
1/2	95.3	38.1	35.1	14.2	See Note(1) To be specified by purchaser	22.4	22.9	23.6	52.3	22.4	22.4	21.3	3.0	15.7
3/4	117.3	47.8	42.9	15.7		27.7	28.2	29.0	57.2	25.4	25.4	26.7	3.0	15.7
1	124	53.8	50.8	17.5		34.5	35.1	35.8	62.0	26.9	26.9	33.5	3.0	17.5
1 1/4	133.4	63.5	63.5	20.6		43.2	43.7	44.5	66.5	28.4	28.4	42.2	4.8	20.6
1 1/2	155.4	69.9	73.2	22.4		49.5	50.0	50.5	69.9	31.8	31.8	48.3	6.4	22.4
2	165.1	84.1	91.9	25.4		62.0	62.5	63.5	73.2	36.6	36.6	60.5	7.9	28.4
2 1/2	190.5	100.1	104.6	28.4		74.7	75.4	76.2	79.2	41.1	41.1	73.2	7.9	31.8
3	209.6	117.3	127.0	31.8		90.7	91.4	92.2	82.6	46.0	46.0	88.9	9.7	35.1
3 1/2	228.6	133.4	139.7	35.1		103.4	104.1	104.9	85.9	49.3	49.3	101.6	9.7	39.6
4	273.1	152.4	157.2	38.1		116.1	116.8	117.6	101.6	53.8	53.8	114.3	11.2	41.1
5	330.2	189.0	185.7	44.5		143.8	144.5	144.5	114.3	60.5	60.5	141.2	11.2	47.8
6	355.6	222.3	215.9	47.8		170.7	171.5	171.5	117.3	66.5	66.5	168.4	12.7	50.8
8	419.1	273.1	269.7	55.6		221.5	222.3	222.3	133.4	76.2	76.2	219.2	12.7	57.2
10	508	342.9	323.9	63.5		276.4	277.4	276.4	152.4	85.9	111.3	273.1	12.7	65.0
12	558.8	400.1	381.0	66.5		327.2	328.2	328.7	155.4	91.9	117.3	323.9	12.7	69.9
14	603.3	431.8	412.8	69.9		359.2	360.2	360.4	165.1	93.7	127.0	355.6	12.7	73.2
16	685.8	495.3	469.9	76.2		410.5	411.2	411.2	177.8	106.4	139.7	406.4	12.7	77.7
18	743	546.1	533.4	82.6		461.8	462.3	462.0	184.2	117.3	152.4	457.2	12.7	79.2
20	812.8	609.6	584.2	88.9		513.1	514.4	512.8	190.5	127.0	165.1	508.0	12.7	82.6
24	939.8	717.6	692.2	101.6		616.0	616.0	614.4	203.2	139.7	184.2	609.6	12.7	91.9

Notes:

- (1) For the inside diameter of pipes (corresponding to 'Bore' (B1) of Welding Neck Flanges), refer to page 83.
- (2) Class 600 flanges except Lap Joint will be furnished with 0.25" (6.35mm) raised face, which is included in 'Thickness' (t) and 'Length through Hub' (T1), (T2).
- (3) For Slip-on, Threaded and Lap joint Flanges, the hubs can be shaped either vertical from base to top or tapered within the limits of 7 degrees.

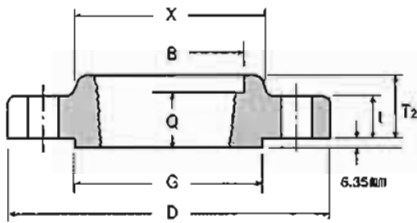

THREADED

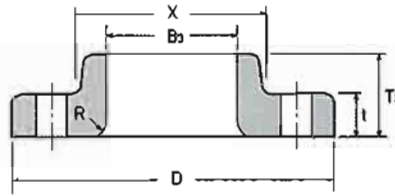

LAP JOINT

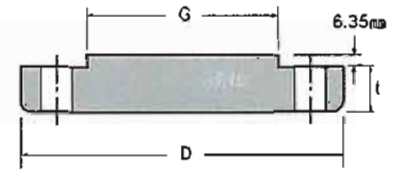

BLIND

CLASS 600 FLANGES

ANSI B16.5 FORGED FLANGES

Unit:mm

Nominal Pipe Size	Depth of Socket Y	DRILLING			BOLTING				APPROXIMATE WEIGHT						
		Bolt Circle Diam	Number of Holes	Diam of Holes	Diam of Bolts (inch)	Stud Bolt Length			Welding Neck			Slip-on and Threaded	Lap Joint	Blind	Socket Welding
						0.25" Raised Face	Male-Female Tongue-Groove	Ring Joint	SCH40	SCH80	SCH160				
1/2	9.7	66.5	4	15.7	1/2	76.2	69.9	76.2	1.36	1.36	1.36	0.91	0.91	0.91	0.91
3/4	11.2	82.6	4	19.1	5/8	88.9	82.6	88.9	1.59	1.63	1.67	1.4	1.4	1.4	1.36
1	12.7	88.9	4	19.1	5/8	88.9	82.6	88.9	1.82	1.87	1.94	1.7	1.7	1.81	1.81
1 1/4	14.2	98.6	4	19.1	5/8	95.3	88.9	95.3	2.50	2.59	2.66	2.27	2.27	2.4	2.6
1 1/2	15.7	114.3	4	22.4	3/4	108.0	101.6	108.0	3.63	3.74	3.88	3.1	3.1	3.4	3.18
2	17.5	127.0	8	19.1	5/8	108.0	101.6	108.0	4.54	4.69	4.98	3.71	3.85	4.4	3.9
2 1/2	19.1	149.4	8	22.4	3/4	120.7	114.3	120.7	6.36	6.66	7.00	5.44	5.44	6.8	5.9
3	20.6	168.1	8	22.4	3/4	127.0	120.7	127.0	8.17	8.58	9.04	7.26	7.26	8.9	7.4
3 1/2	22.4	184.2	8	25.4	7/8	139.7	133.4	139.7	12.00	12.44	13.28	9.53	9.53	13.17	
4	23.9	215.9	8	25.4	7/8	146.1	139.7	146.1	16.80	17.46	18.79	14.97	15.40	18.6	
5	23.9	266.7	8	28.4	1	165.1	158.8	165.1	30.90	32.27	34.30	28.5	29	30.84	
6	26.9	292.1	12	28.4	1	171.5	165.1	171.5	36.77	34.93	37.69	36.32	36.5	33.80	
8	31.8	349.3	12	31.8	1 1/8	190.5	184.2	196.9	50.90	53.98	60.16	44	50.8	62.2	
10	33.3	431.8	16	35.1	1 1/4	215.9	209.6	215.9	86.26	92.59	103.34	76.2	82	102	
12	39.6	489.0	20	35.1	1 1/4	222.3	215.9	222.3	102.60	112.36	128.19	97.52	108.86	132	
14	41.4	527.1	20	38.1	1 3/8	235.0	228.6	235.0	121.60	136.13	156.38	102	111.20	158	
16	44.5	603.3	20	41.1	1 1/2	254.0	247.7	254.0	177.10	198.70	226.80	149.82	165.71	224.13	
18	49.3	654.1	20	44.5	1 5/8	273.1	266.7	273.1	215.70	246.66	283.01	180.1	219.4	285	
20	54.1	723.9	24	44.5	1 5/8	285.8	279.4	292.1	268.00	310.23	356.13	231.54	258.8	365	
24	63.5	838.2	24	50.8	1 7/8	330.2	323.9	336.6	372.00	495.71	512.38	330	362	536.80	

- (4) Blind Flanges may with the same hub as that used for Slip-on Flanges or without hub.
- (5) The gasket surface and backside (bearing surface for bolting) are made parallel within 1 degree. To accomplish parallelism, spot facing is carried out according to MSS SP-9, without reducing thickness (t).
- (6) Dimensions of sizes 1/2" through 3 1/2" are the same as for Class 400 Flanges.
- (7) Depth of Socket (Y) is covered by ANSI B16.5 only in sizes through 3 inch, over 3 inch is at the manufacture's option.

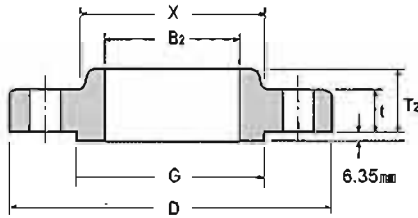

SLIP-ON

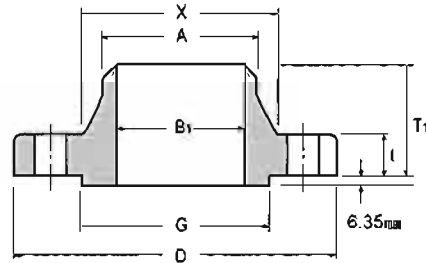

WELDING NECK

CLASS 900 FLANGES

ANSI B16.5 FORGED FLANGES

Unit:mm

Nominal Pipe Size	Outside Diam.	Diam. at Base of Hub	O.D of Raised Face	Thick-ness	BORE				LENGTH THRU HUB			Diam. of Hub at Bevel
					Welding Neck	Slip-on	Lap Joint	Counter Bore Min.	Welding Neck	Slip-on Threaded Socket Welding	Lap Joint	
					B1	B2	B3	B	T1	T2	T3	
1/2	120.7	38.1	35.1	22.4	---	22.4	22.9	23.6	60.5	31.8	31.8	21.3
3/4	130	44.5	42.9	25.4	---	27.7	28.2	29.0	69.9	35.1	35.1	26.7
1	149.4	52.3	50.8	28.4	---	34.5	35.1	35.8	73.2	41.1	41.1	33.5
1 1/4	158.8	63.5	63.5	28.4	---	43.2	43.7	44.5	73.2	41.1	41.1	42.2
1 1/2	177.8	69.9	73.2	31.8	---	49.5	50.0	50.5	82.6	44.5	44.5	48.3
2	215.9	104.6	91.9	38.1	---	62.0	62.5	63.5	101.6	57.2	57.2	60.5
2 1/2	244.3	124.0	104.6	41.1	---	74.7	75.4	76.2	104.6	63.5	63.5	73.2
3	241.3	127.0	127.0	38.1	---	90.7	91.4	92.2	101.6	53.8	53.8	88.9
4	292.1	158.8	157.2	44.5	---	116.1	116.8	117.6	114.3	69.9	69.9	114.3
5	349.3	190.5	185.7	50.8	---	143.8	144.5	144.5	127.0	79.2	79.2	141.2
6	381	235.0	215.9	55.6	---	170.7	171.5	171.5	139.7	85.9	85.9	168.4
8	469.9	298.5	269.7	63.5	---	221.5	222.3	222.3	162.1	101.6	114.3	219.2
10	546.1	368.3	323.9	69.9	---	276.4	277.4	276.4	184.2	108.0	127.0	273.1
12	609.6	419.1	381.0	79.2	---	327.2	328.2	328.7	200.2	117.3	142.7	323.9
14	641.4	450.9	412.8	85.9	---	359.2	360.4	360.4	212.9	130	155.4	355.6
16	704.9	508.0	469.9	88.9	---	410.5	411.2	411.2	215.9	133.4	165.1	406.4
18	787.4	565.2	533.4	101.6	---	461.8	462.3	462.0	228.6	152.4	190.5	457.2
20	857.3	622.3	584.2	108.0	---	513.1	514.4	512.8	247.7	158.8	209.6	508.0
24	1041.4	749.3	692.2	139.7	---	616.0	616.0	614.4	292.1	203.2	266.7	609.6

See Note(1)
To be specified by purchaser

Notes:

- (1) For the inside diameter of pipes (corresponding to 'Bore' (B1) of Welding Neck Flanges), refer to page 83.
- (2) Class 900 flanges except Lap Joint will be furnished with 0.25" (6.35mm) raised face, which is included in 'Thickness' (t) and 'Length through Hub' (T1), (T2).
- (3) For Slip-on, Threaded, and Lap Joint Flanges, the hubs can be shaped either vertical from base to top or tapered within the limits of 7 degrees.

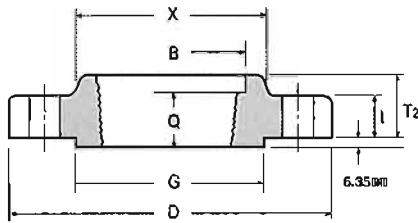

THREADED

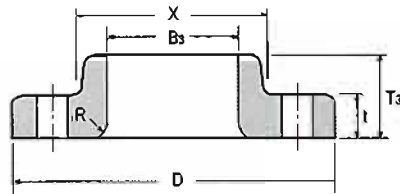

LAP JOINT

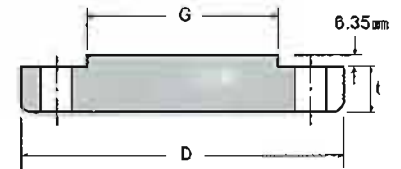

BLIND

CLASS 900 FLANGES

ANSI B16.5 FORGED FLANGES

Unit:mm

Nominal Pipe Size	Radius of fillet R	Thread Length Q	DRILLING			BOLTING			APPROXIMATE WEIGHT						
			Bolt Circle Diam	Number of Holes	Diam of Holes	Diam of Bolts (inch)	Stud Bolt Length			Welding Neck			Slip-on and Threaded	Lap Joint	Blind
							0.25" Raised Face	Male-Female Tongue-Groove	Ring Joint	SCH40	SCH80	SCH160			
1/2	3.0	22.4	82.6	4	22.4	3/4	108.0	101.6	108.0	3.10	3.10	3.10	1.81	1.8	1.9
3/4	3.0	25.4	88.9	4	22.4	3/4	114.3	108.0	114.3	3.18	3.18	3.18	2.4	2.4	2.7
1	3.0	28.4	101.6	4	25.4	7/8	127.0	120.7	127.0	3.86	3.92	4.00	3.50	3.60	4.09
1 1/4	4.8	30.2	111.3	4	25.4	7/8	127.0	120.7	127.0	4.54	4.64	4.71	4.1	4.1	4.54
1 1/2	6.4	31.8	124.0	4	28.4	1	139.7	133.4	139.7	6.36	6.49	6.65	5.52	5.55	5.93
2	7.9	38.1	165.1	8	25.4	7/8	146.1	139.7	146.1	10.90	11.10	11.50	9.98	9.98	11.34
2 1/2	7.9	47.8	190.5	8	28.4	1	158.8	152.4	158.8	16.30	16.69	17.14	15.8	15.8	16.00
3	9.7	41.1	190.5	8	25.4	7/8	146.1	139.7	146.1	15.00	15.50	16.10	11.8	11.8	13.17
4	11.2	47.8	235.0	8	31.8	1 1/8	171.5	165.1	171.5	23.20	23.94	25.43	23.2	23.2	24.5
5	11.2	53.8	279.4	8	35.1	1 1/4	190.5	184.2	190.5	39.10	40.62	42.86	37.65	36.74	39.46
6	12.7	57.2	317.5	12	31.8	1 1/8	190.5	184.2	196.9	49.90	52.06	55.33	48.3	49	51.5
8	12.7	63.5	393.7	12	38.1	1 3/8	222.3	215.9	222.3	84.90	88.61	96.09	75	86	89
10	12.7	71.4	469.9	16	38.1	1 3/8	235.0	228.6	235.0	121.70	129.87	142.79	111.3	125.64	131.54
12	12.7	76.2	533.4	20	38.1	1 3/8	254.0	247.7	254.0	157.00	169.48	189.74	146	167.00	187
14	12.7	82.6	558.8	20	41.1	1 1/2	273.1	266.7	292.1	181.00	199.62	225.55	172.36	180.07	224.07
16	12.7	85.9	616.0	20	44.5	1 5/8	285.8	279.4	298.5	225.00	251.11	285.08	192.95	211.10	272.4
18	12.7	88.9	685.8	20	50.8	1 7/8	323.9	317.5	333.6	309.00	347.24	392.13	272.4	295.10	385.9
20	12.7	91.9	749.3	20	53.8	2	349.3	342.9	362.0	377.00	431.59	490.91	331.42	367.70	488
24	12.7	101.6	901.7	20	66.5	2 1/2	438.2	431.8	457.2	685.00	778.36	885.21	632	703.70	905

- (4) Blind Flanges may be made with the same hub as that used for Slip-on Flanges or without hub.
- (5) The gasket surface and backside (bearing surface for bolting) are made parallel within 1 degree. To accomplish parallelism, spot facing is carried out according to MSS SP-9, without reducing thickness (t).
- (6) Dimensions of sizes 1/2' through 2 1/2' are the same as for Class 1500 Flanges.

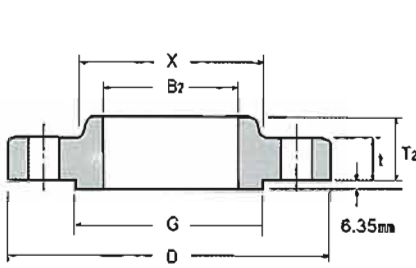

SLIP-ON

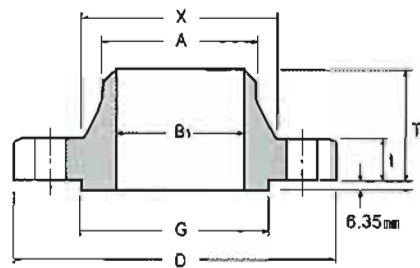

WELDING NECK

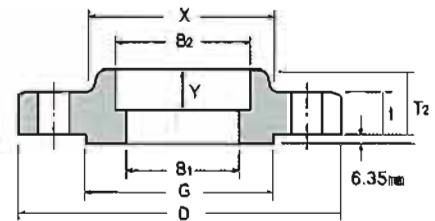

SOCKET WELDING

CLASS 1500 FLANGES

ANSI B16.5 FORGED FLANGES

Unit:mm

Nominal Pipe Size	Outside Diam. D	Diam. at Base of Hub X	O.D of Raised Face G	Thick-ness t	BORE				LENGTH THRU HUB			Diam. of Hub at Bevel A	Radius of Fillet R	Thread Length Q	
					Welding Neck Socket Welding B1	Slip-on Socket Welding B2	Lap Joint B3	Counter Bore Min. Threaded Min. B	Welding Neck T1	Slip-on Threaded Socket Welding T2	Lap Joint T3				
1/2	120.7	38.1	35.1	22.4		22.4	22.9	23.6		60.5	31.8	31.8	21.3	3.0	22.4
3/4	130	44.5	42.9	25.4		27.7	28.2	29.0		69.9	35.1	35.1	26.7	3.0	25.4
1	149.4	52.3	50.8	28.4		34.5	35.1	35.8		73.2	41.1	41.4	33.5	3.0	28.4
1 1/4	158.8	63.5	63.5	28.4		43.2	43.7	44.5		73.2	41.1	41.1	42.2	4.8	30.2
1 1/2	177.8	69.9	73.2	31.8		49.5	50.0	50.5		82.6	44.5	44.5	48.3	6.4	31.8
2	215.9	104.6	91.9	38.1		62.0	62.5	63.5		101.6	57.2	57.2	60.5	7.9	38.1
2 1/2	244.3	124.0	104.6	41.1		74.7	75.4	76.2		104.6	63.5	63.5	73.2	7.9	47.8
3	266.7	133.4	127.0	47.8		90.7	91.4	92.2		117.3	73.2	73.2	88.9	9.7	50.8
4	311.2	162.1	157.2	53.8		116.1	116.8	117.6		124.0	90.4	90.4	114.3	11.2	57.2
5	374.7	196.9	185.7	73.2		143.8	144.5	144.5		155.4	104.6	104.6	141.2	11.2	63.5
6	393.7	228.6	215.9	82.6		170.7	171.5	171.5		171.5	119.1	119.1	168.4	12.7	69.9
8	482.6	292.1	269.7	91.9		221.5	222.3	222.3		212.9	142.7	142.7	219.2	12.7	76.2
10	584.2	368.3	323.9	108.0		276.4	277.4	276.4		254.0	158.8	177.8	273.1	12.7	84.1
12	673.1	450.9	381.0	124.0		327.2	328.2	328.7		282.4	180.8	218.9	323.9	12.7	91.9
14	749.3	495.3	412.8	133.4		359.2	360.2	360.4		298.5	-	241.3	355.6	12.7	-
16	825.5	552.5	469.9	146.1		410.5	411.2	411.2		311.2	-	260.4	406.4	12.7	-
18	914.4	596.9	533.4	162.1		461.8	462.3	462.0		327.2	-	276.4	457.2	12.7	-
20	984.3	641.4	584.2	177.8		513.1	514.4	512.8		355.6	-	292.1	508.0	12.7	-
24	1168.4	762.0	692.2	203.2		616.0	616.0	614.4		406.4	-	330.2	609.6	12.7	-

See Note(1)
To be specified by purchaser

Notes:

- (1) For the inside diameter of pipes (corresponding to 'Bore' (B1) of Welding Neck Flanges), refer to page 83.
- (2) Class 1500 flanges except Lap Joint will be furnished with 0.25" (6.35mm) raised face, which is not included in 'Thickness' (t) and 'Length through Hub' (T1), (T2).
- (3) For Slip-on, Threaded Lap Joint and Socket Welding Flanges, the hubs can be shaped either vertical from base to top or tapered within the limits 7 degrees.

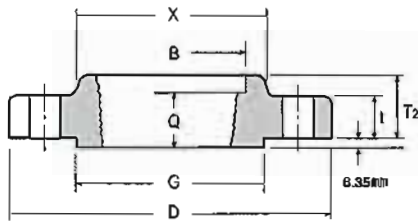

THREADED

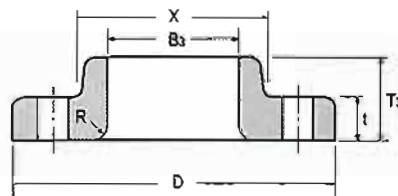

LAP JOINT

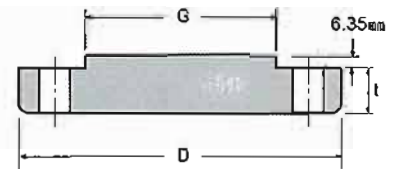

BLIND

CLASS 1500 FLANGES

ANSI B16.5 FORGED FLANGES

Unit:mm

Nominal Pipe Size	Depth of Socket Y	DRILLING			BOLTING				APPROXIMATE WEIGHT						
		Bolt Circle Diam	Number of Holes	Diam of Holes	Diam of Bolts (inch)	Stud Bolt Length			Welding Neck			Slip-on and Threaded	Lap Joint	Blind	Socket Welding
						0.25" Raised Face	Male-Female Tongue-Groove	Ring Joint	SCH40	SCH80	SCH160				
1/2	9.7	82.6	4	22.4	3/4	108.0	101.6	108.0	3.10	3.10	3.10	1.8	1.9	1.9	1.81
3/4	11.2	88.9	4	22.4	3/4	114.3	108.0	114.3	3.18	3.18	3.18	2.35	2.35	2.72	2.81
1	12.7	101.6	4	25.4	7/8	127.0	120.7	127.0	3.86	3.92	4.00	3.50	3.60	4.08	3.61
1 1/4	14.21	113	4	25.4	7/8	127.0	120.7	127.0	4.54	4.64	4.71	4.1	4.10	4.3	4.99
1 1/2	15.71	124.0	4	28.4	1	139.7	133.4	139.7	6.36	6.49	6.65	5.45	5.45	5.9	6.76
2	17.5	165.1	8	25.4	7/8	146.1	139.7	146.1	10.90	11.10	11.50	10.5	10.45	11.3	10.89
2 1/2	19.1	190.5	8	28.4	1	158.8	152.4	158.8	16.34	16.69	17.14	15.8	15.8	16	16.34
3	20.6	203.2	8	31.8	1 1/8	177.8	171.5	177.8	21.80	22.37	23.01	21.80	21.80	21.79	
4	23.9	241.3	8	35.1	1 1/4	196.9	190.5	196.9	31.30	32.10	33.71	33.10	34.10	33.11	
5	23.9	292.1	8	41.1	1 1/2	247.7	241.3	247.7	59.90	61.75	64.47	59.00	63.60	60	
6	26.9	317.5	12	38.1	1 3/8	260.4	254.0	266.7	74.19	77.13	81.12	74	77	75	
8	31.8	393.7	12	44.5	1 5/8	292.1	285.8	323.9	124.00	128.83	138.56	117.73	129.73	136.98	
10	33.3	482.6	12	50.8	1 7/8	336.6	330.2	342.9	206.00	217.16	234.82	197.50	220.19	229.97	
12	39.6	571.5	16	53.8	2	374.7	368.3	387.4	306	330.75	359.07	264	288.00	316.40	
14	41.4	635.0	16	60.5	2 1/4	406.4	400.1	425.5	416	431.88	467.94		404.10	421	
16	44.5	704.9	16	66.5	2 1/2	444.5	438.2	469.9	567	562.30	610.84		522.10	559	
18	49.3	774.7	16	73.2	2 3/4	495.3	489.0	527.1	736	741.28	790.00		670.00	761.60	
20	54.1	831.9	16	79.2	3	539.8	533.4	565.2	929	892.00	980.00		806.00	967	
24	63.5	990.6	16	91.9	3 1/2	616.0	609.6	647.7	1504	1430.00	1580.00		1285.5	1568	

(4) Blind Flanges may be made with the same hub as that used for Slip-on Flanges or without hub.

(5) The gasket surface and backside (bearing surface for bolting) are made parallel within 1 degree. To accomplish parallelism, and facing is carried out according to MSS SP-9, without reducing thickness (t).

(6) Dimensions of sizes 1/2" through 2 1/2" are the same as for Class 900 Flanges.

(7) Depth of Socket (Y) is covered by ANSI B16.5 only in sizes through 2 1/2 inch, over 2 1/2 inch is at the manufacturer's option.

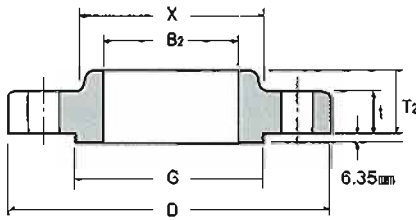

SLIP-ON

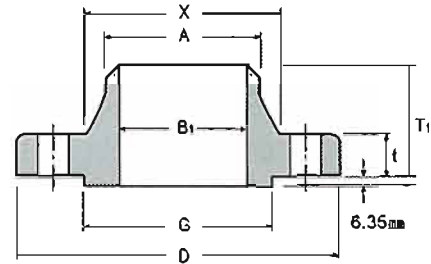

WELDING NECK

CLASS 2500 FLANGES

ANSI B16.5 FORGED FLANGES

Unit:mm

Nominal Pipe Size	Outside Diam.	Diam. at Base of Hub	O.D of Raised Face	Thick-ness	BORE				LENGTH THRU HUB			Diam. of Hub at Bevel	Radius of Fillet	Thread Length
					Welding Neck Socket Welding	Slip-on Socket Welding	Lap Joint	Counter Bore Min. Threaded Min.	Welding Neck	Slip-on Threaded Socket Welding	Lap Joint			
					B1	B2	B3	B	T1	T2	T3			
1/2	133.4	42.9	35.1	30.2	To be specified by purchaser	22.4	22.9	23.6	73.2	39.6	39.6	21.3	3.0	28.4
3/4	139.7	50.8	42.9	31.8		27.7	28.2	29.0	79.2	42.9	42.9	26.7	3.0	31.8
1	158.8	57.2	50.8	35.1		34.5	35.1	35.8	88.9	47.8	47.8	33.5	3.0	35.1
1 1/4	184.2	73.2	63.5	38.1		43.2	43.7	44.5	95.3	52.3	52.3	42.2	4.8	38.1
1 1/2	203.2	79.2	73.2	44.5		49.5	50.0	50.5	111.3	60.5	60.5	48.3	6.4	44.5
2	235	95.3	91.9	50.8		62.0	62.5	63.5	127.0	69.9	69.9	60.5	7.9	50.8
2 1/2	266.7	114.3	104.6	57.2		74.7	75.4	76.2	142.7	79.2	79.2	73.2	7.9	57.2
3	304.8	133.4	127.0	66.5		90.7	91.4	92.2	168.1	91.9	91.9	88.9	9.7	63.5
4	355.6	165.1	157.2	76.2		116.1	116.8	117.6	190.5	108.0	108.0	114.3	11.2	69.9
5	419.1	203.2	185.7	91.9		143.8	144.5	144.5	228.6	130.0	130.0	141.2	11.2	76.2
6	482.6	235.0	215.9	108.0		170.7	171.5	171.5	273.1	152.4	152.4	168.4	12.7	82.6
8	552.5	304.8	269.7	127.0		221.5	222.3	222.3	317.5	177.8	177.8	219.2	12.7	95.3
10	673.1	374.7	323.9	165.1	276.4	277.4	276.4	419.1	228.6	228.6	273.1	12.7	108.0	
12	762	441.5	381.0	184.2	327.2	328.2	328.7	463.6	254.0	254.0	232.9	12.7	120.7	

Notes:

- (1) For the inside diameter of pipes (corresponding to 'Bore' (B1) of Welding Neck Flanges.), refer to page 83.
- (2) Class 2500 flanges except Lap Joint will be furnished with 0.25" (6.35mm) raised face, which is included in Thickness (t) and 'Length through Hub' (T1), (T2).
- (3) For Slip-on, Threaded and Lap Joint Flanges, the hubs can be shaped either vertical from base to top or tapered within the limits of 7 degrees.

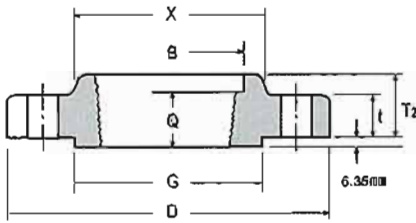

THREADED

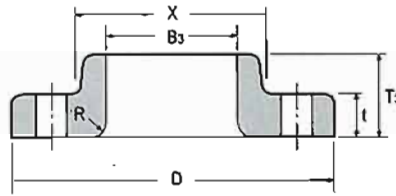

LAP JOINT

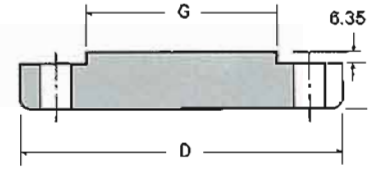

BLIND

CLASS 2500 FLANGES

ANSI B16.5 FORGED FLANGES

Unit:mm

Nominal Pipe Size	DRILLING			BOLTING				APPROXIMATE WEIGHT			
	Bolt Circle Diam	Number of Holes	Diam of Holes	Diam of Bolts (inch)	Stud Bolt Length			Welding Neck	Slip-on and Threaded	Lap Joint	Blind
					0.25" Flaired Face	Male-Female Tongue-Groove	Ring Joint				
1/2	88.9	4	22.4	3/4	120.7	114.3	120.7	3.63	3.20	3.20	3.11
3/4	95.3	4	22.4	3/4	127.0	120.7	127.0	4.09	4.08	4.08	4.54
1	108.0	4	25.4	7/8	139.7	133.4	139.7	5.90	5.44	5.44	5.44
1 1/4	130.0	4	28.4	1	152.4	146.1	152.4	9.08	8.16	8.16	8.16
1 1/2	146.1	4	31.8	1 1/8	171.5	165.1	171.5	12.70	11.00	11.00	10.44
2	171.5	8	28.4	1	177.8	171.5	177.8	19.10	17.25	17.25	17.71
2 1/2	196.9	8	31.8	1 1/8	196.9	190.5	203.2	23.60	25.00	25.00	25.42
3	228.6	8	35.1	1 1/4	222.3	215.9	228.6	42.70	37.70	37.70	39.04
4	273.1	8	41.1	1 1/2	254.0	247.7	260.4	66.30	58.00	58.00	60.38
5	323.9	8	47.8	1 3/4	298.5	292.1	311.2	110.80	95.30	95.30	101.15
6	368.3	8	53.8	2	342.9	336.6	355.6	176.46	146.51	147.00	156.63
8	438.2	12	53.8	2	381.0	374.7	393.7	261.50	220.00	220.00	240.62
10	539.8	12	66.5	2 1/2	489.0	482.6	508.0	484.50	421.00	421.00	465.36
12	619.3	12	73.2	2 3/4	539.8	533.4	558.8	730.00	590.00	590.00	664.1

(4) Blind Flanges may be made with the same hub as that used for Slip-on Flanges or without hub.

(5) The gasket surface and backside (bearing surface for bolting) are made parallel within 1 degree. To accomplish parallelism, spot facing is carried out according to MSS SP-9, without reducing thickness (t).

(6) Class 2500 Slip-on Flanges are not covered by ANSI B16.5, slip-on flanges are at the manufacturer's option.

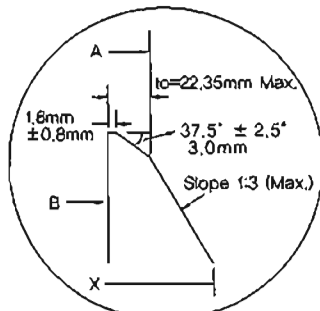

BEVEL FOR WALL THICKNESS(*t*)
0.68" IN.(22.36mm) OR LESS.

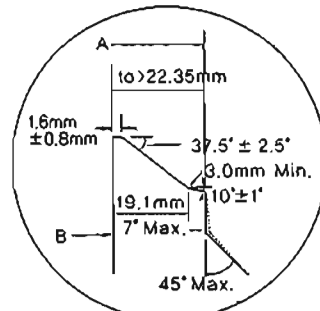

BEVEL FOR WALL THICKNESS(*t*)
GREATER THAN 0.68 IN.(22.35mm)

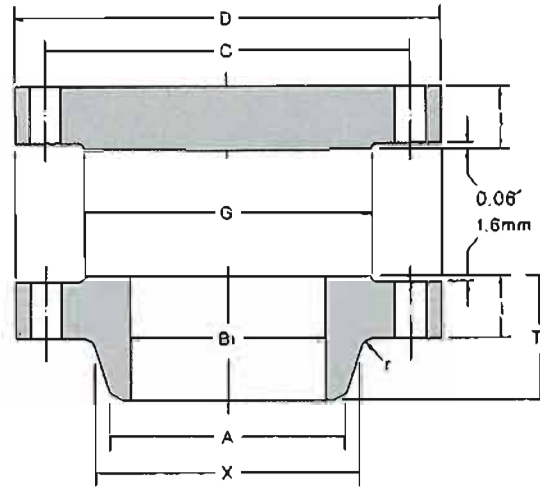

CLASS 75 FLANGES

ASME B16.47 SER.B (API 605)

Unit:mm

Nominal Pipe Size	Outside Diam.	O.D of Raised Face	Diam. of Hub at Base	Diam. of Hub at Bevel	BORE			Length Thru Hub	THICKNESS		Radius at Base of Hub	DRILLING			Approximate Weight(kg)	
					Wall Thickness				Blind	Welding Neck		Bolt Circle Diam	Number of Holes	Diam. of Holes	Welding neck	Blind
					6.35mm	9.5mm	12.7mm									
D	G	X	A	B1			T1	t	t	r	c					
26	762	704.9	676.1	661.9	647.7	641.4	635.0	58.7	33.3	33.3	7.9	723.9	36	19.1	36.3	115.7
28	813	755.7	726.9	712.7	698.5	692.2	685.8	62.0	33.3	33.3	7.9	774.7	40	19.1	38.6	131.5
30	864	806.5	777.7	763.5	749.3	743.0	736.6	65.0	33.3	33.3	7.9	825.5	44	19.1	40.8	149.7
32	914	857.3	828.5	814.3	800.1	793.8	787.4	69.9	36.6	35.1	7.9	876.3	48	19.1	47.6	176.9
34	965	908.1	879.3	865.1	850.9	844.6	838.2	73.2	38.1	35.1	7.9	927.1	52	19.1	49.9	195.0
36	1034	965.2	935.0	915.9	850.9	895.4	889.0	85.9	42.4	36.6	9.7	992.1	40	22.4	65.8	235.0
38	1084	1016.0	985.8	966.7	952.5	946.2	939.8	88.9	44.5	38.1	9.7	1042.9	40	22.4	72.6	269.9
40	1135	1066.8	1036.6	1017.5	1003.3	997.0	990.6	91.9	44.5	38.1	9.7	1093.7	44	22.4	77.1	344.7
42	1186	1117.6	1087.4	1068.3	1054.1	1047.8	1041.4	95.3	47.8	39.6	9.7	1144.5	48	22.4	83.9	406.0
44	1251	1174.8	1140.0	1119.1	1104.9	1098.6	1092.2	104.6	49.3	42.9	9.7	1203.5	36	25.4	104.3	483.1
46	1302	1225.6	1190.8	1169.9	1155.7	1149.4	1143.0	108.0	50.8	44.5	9.7	1254.3	40	25.4	111.1	537.5
48	1353	1276.4	1241.6	1220.7	1206.5	1200.2	1193.8	111.3	53.8	46.0	9.7	1305.1	44	25.4	122.5	596.5
50	1403	1327.2	1293.9	1271.5	1257.3	1251.0	1244.6	115.8	55.4	47.8	9.7	1355.9	44	25.4	131.5	682.7
52	1457	1378.0	1344.7	1322.3	1308.1	1301.8	1295.4	120.7	57.2	47.8	9.7	1409.7	48	25.4	140.6	755.2
54	1508	1428.8	1397.0	1373.1	1358.9	1352.6	1346.2	125.5	60.5	49.3	9.7	1460.5	48	25.4	154.2	834.6
56	1575	1485.9	1450.8	1423.9	1409.7	1403.4	1397.0	134.9	62.0	50.8	11.2	1521.0	40	28.4	181.4	957.1
58	1626	1536.7	1501.6	1474.7	1460.5	1454.2	1447.8	138.2	63.5	52.3	11.2	1571.8	44	28.4	195.0	1043.3
60	1676	1587.5	1552.4	1525.5	1511.3	1505.0	1498.6	144.5	66.5	55.6	11.2	1622.6	44	28.4	215.5	1134.0

Notes

(1) 'Bore' (B1) of flanges shall be specified by the purchaser.

(2) Class 300 flanges will be furnished with 0.06" (1.6mm) raised face which is included in 'Thickness' (t) and 'Length thru Hub' (T1).

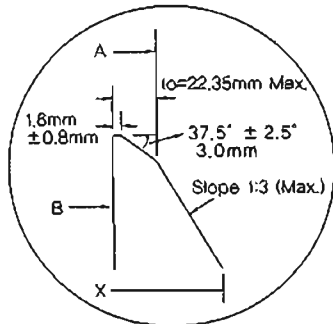

BEVEL FOR WALL THICKNESS(*t*)
0.88" IN.(22.35mm) OR LESS.

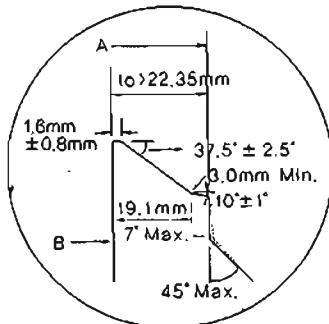

BEVEL FOR WALL THICKNESS(*t*)
GREATER THAN 0.88 IN.(22.35mm)

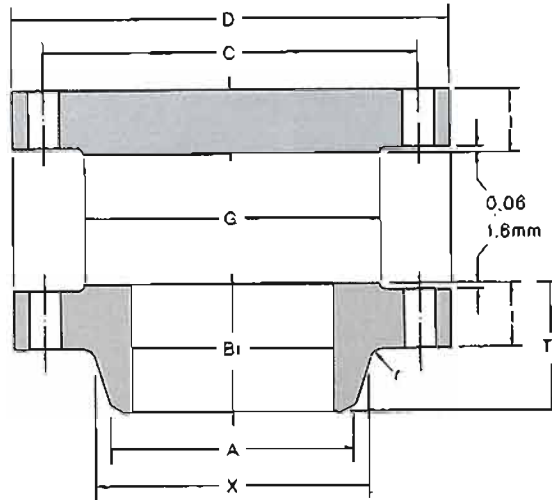

CLASS 150 FLANGES

ASME B16.47 SER.B (API 605)

Unit:mm

Nominal Pipe Size	Outside Diam.	O.D of Raised Face	Diam. of Hub at Base	Diam. of Hub at Bevel	BORE			Length Thru Hub	THICKNESS		Radius at Base of Hub	DRILLING			Approximate Weight(kg)	
					Wall Thickness				Blind	Welding		Bolt Circle Diam	Number of Holes	Diam. of Holes	Welding neck	Blind
					6.35mm	9.5mm	12.7mm									
D	G	X	A	B1			T1	t	t	r	c					
26	786	711.2	684.3	661.9	647.7	641.4	635.0	88.9	44.5	41.1	9.7	744.5	36	22.4	54.4	169.2
28	837	762.0	735.1	712.7	698.5	692.2	685.8	95.3	47.8	44.5	9.7	795.3	40	22.4	63.5	205.9
30	887	812.8	787.4	763.5	749.3	743.0	736.6	100.1	50.8	44.5	9.7	846.1	44	22.4	68.0	246.3
32	941	863.6	839.7	814.3	800.1	793.8	787.4	108.0	53.8	46.0	9.7	900.2	48	22.4	77.1	293.9
34	1005	920.8	892.0	865.1	850.9	844.6	838.2	110.2	57.2	49.3	9.7	957.3	40	25.4	95.3	355.2
36	1057	971.6	944.6	915.9	901.7	895.4	889.0	117.3	58.7	52.3	9.7	1009.7	44	25.4	108.9	403.7
38	1124	1022.4	997.0	968.2	952.5	946.2	939.8	124.0	63.5	53.8	9.7	1069.8	40	28.4	131.5	494.0
40	1175	1079.5	1049.3	1019.0	1003.3	997.0	990.6	128.5	66.5	55.6	9.7	1120.6	44	28.4	140.6	565.6
42	1226	1130.3	1101.9	1069.8	1054.1	1047.8	1041.4	133.4	68.3	58.7	11.2	1171.4	48	28.4	156.5	631.9
44	1276	1181.1	1152.7	1120.6	1104.9	1098.6	1092.2	136.7	71.4	60.5	11.2	1222.2	52	28.4	167.8	716.2
46	1341	1234.9	1205.0	1171.4	1155.7	1149.4	1143.0	144.5	74.7	62.0	11.2	1284.2	40	31.8	197.3	827.4
48	1392	1289.1	1257.3	1222.2	1206.5	1200.2	1193.8	149.4	77.7	65.0	11.2	1335.0	44	31.8	217.7	927.6
50	1443	1339.9	1308.1	1273.0	1257.3	1251.0	1244.6	153.9	80.8	68.3	11.2	1385.8	48	31.8	235.9	1036.0
52	1494	1390.7	1360.4	1323.8	1308.1	1301.8	1295.4	157.2	84.1	69.9	11.2	1438.6	52	31.8	249.5	1155.3
54	1549	1441.5	1412.7	1374.6	1358.9	1352.6	1346.2	162.1	87.4	71.4	11.2	1492.3	56	31.8	281.2	1291.9
56	1800	1492.3	1465.3	1425.4	1409.7	1403.4	1397.0	166.6	90.4	73.2	14.2	1543.1	60	31.8	294.8	1426.1
58	1675	1543.1	1516.1	1476.2	1460.5	1454.2	1447.8	174.8	93.5	74.7	14.2	1611.4	48	35.1	353.8	1614.8
60	1726	1600.2	1570.0	1527.0	1511.3	1505.0	1498.6	179.3	96.8	76.2	14.2	1662.2	52	35.1	385.6	1774.9

Notes

(1) 'Bore' (B1) of flanges shall be specified by the purchaser.

(2) Class 300 flanges will be furnished with 0.06" (1.6mm) raised face which is included in 'Thickness' (t) and 'Length thru Hub' (T1).

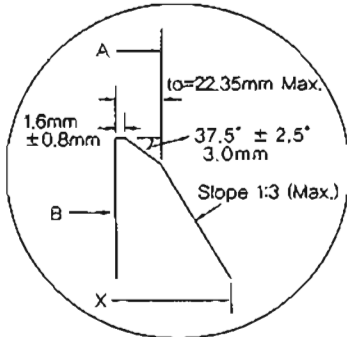

BEVEL FOR WALL THICKNESS(to)
0.88" IN.(22.35mm) OR LESS.

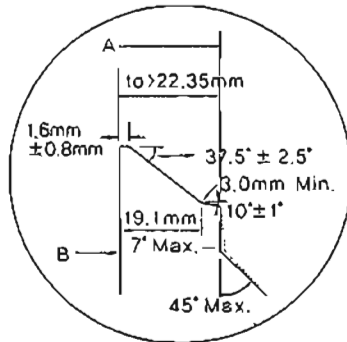

BEVEL FOR WALL THICKNESS(to)
GREATER THAN 0.88 IN.(22.35mm)

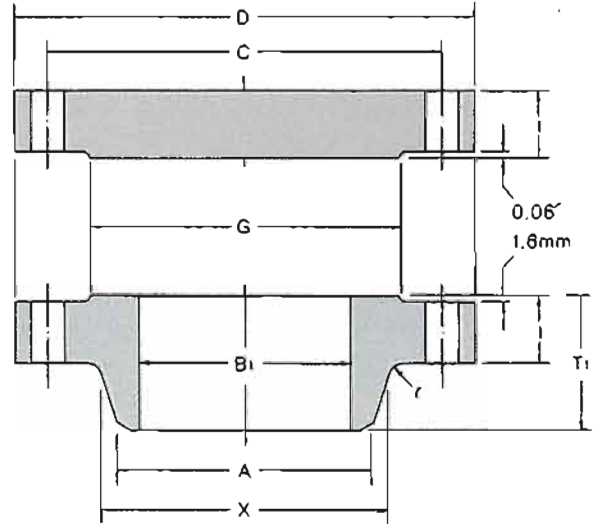

CLASS 300 FLANGES

ASME B16.47 SER.B(API 605)

Unit:mm

Nominal Pipe Size	Outside Diam.	O.D of Raised Face	Diam. of Hub at Base	Diam. of Hub at Bevel	BORE			Length Thru Hub	THICKNESS		Radius at Base of Hub	DRILLING			Approximate Weight(kg)	
					Wall Thickness				Blind	Welding Neck		Bolt Circle Diam	Number of Holes	Diam. of Holes	Welding neck	Blind
					6.35mm	9.5mm	12.7mm									
D	G	X	A	B1			T1	t	t	r	c					
26	867	736.6	701.5	665.2	647.7	641.4	635.0	144.5	88.9	88.9	14.2	803.1	32	35.1	181.4	411.4
28	921	787.4	755.7	716.0	698.5	692.2	685.8	149.4	88.9	88.9	14.2	857.3	36	35.1	204.1	464.0
30	991	844.6	812.8	768.4	749.3	743.0	736.6	158.0	93.7	93.7	14.2	920.8	36	38.1	249.5	566.5
32	1054	901.7	863.6	819.2	800.1	793.8	787.4	168.1	103.1	103.1	15.7	977.9	32	41.1	310.7	705.8
34	1108	952.5	917.4	870.0	850.9	844.6	838.2	173.0	103.1	103.1	15.7	1031.7	36	41.1	340.2	779.7
36	1171	1009.7	965.2	920.8	901.7	895.4	889.0	180.8	103.1	103.1	15.7	1089.2	32	44.5	381.0	871.4
38	1222	1060.5	1016.0	971.6	952.5	946.2	939.8	192.0	111.3	111.3	15.7	1140.0	36	44.5	415.0	1023.8
40	1273	1114.6	1066.8	1022.4	1003.3	997.0	990.6	198.4	115.8	115.8	15.7	1190.8	40	44.5	449.1	1156.2
42	1334	1168.4	1117.6	1074.7	1054.1	1047.8	1041.4	204.7	119.1	119.1	15.7	1244.6	36	47.8	514.8	1304.6
44	1384	1219.2	1173.2	1125.5	1104.9	1098.6	1092.2	214.4	127.0	127.0	15.7	1295.4	40	47.8	560.2	1498.7
46	1461	1270.0	1228.9	1176.3	1155.7	1149.4	1143.0	222.3	130.0	128.5	15.7	1365.3	36	50.8	666.8	1708.3
48	1511	1327.2	1277.9	1227.1	1206.5	1200.2	1193.8	223.8	134.9	128.5	15.7	1416.1	40	50.8	714.4	1897.4
50	1562	1378.0	1330.5	1277.9	1257.3	1251.0	1244.6	235.0	139.7	138.2	15.7	1466.9	44	50.8	775.7	2099.7
52	1613	1428.8	1382.8	1328.7	1308.1	1301.8	1295.4	242.8	144.3	142.7	15.7	1517.7	48	50.8	834.6	2311.5
54	1673	1479.6	1435.1	1379.5	1358.9	1352.6	1346.2	239.8	149.4	136.7	15.7	1577.8	48	50.8	898.1	2575.5
56	1765	1536.7	1493.8	1430.3	1409.7	1403.4	1397.0	268.2	157.0	153.9	17.5	1651.0	36	60.5	1177.1	3012.8
58	1827	1593.9	1547.9	1481.1	1460.5	1454.2	1447.8	274.6	162.1	153.9	17.5	1712.0	40	60.5	1256.6	3332.6
60	1878	1651.0	1598.7	1531.9	1511.3	1505.0	1498.6	271.5	166.6	150.9	17.5	1763.8	40	60.5	1301.8	3619.7

Notes

(1) 'Bore' (B1) of flanges shall be specified by the purchaser.

(2) Class 300 flanges will be furnished with 0.06" (1.6mm) raised face which is included in 'Thickness' (t) and 'Length thru Hub' (T1).

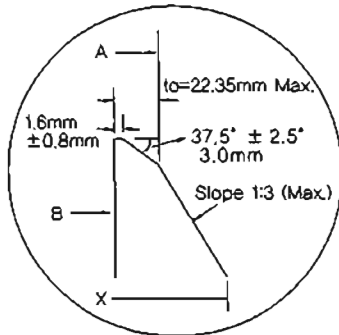

BEVEL FOR WALL THICKNESS(t_o)
0.88" IN.(22.35mm) OR LESS.

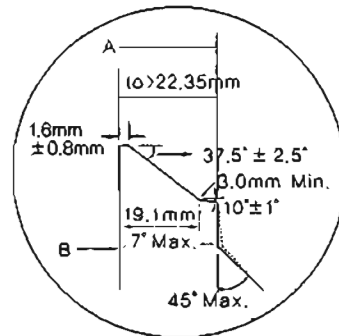

BEVEL FOR WALL THICKNESS(t_o)
GREATER THAN 0.88 IN.(22.35mm)

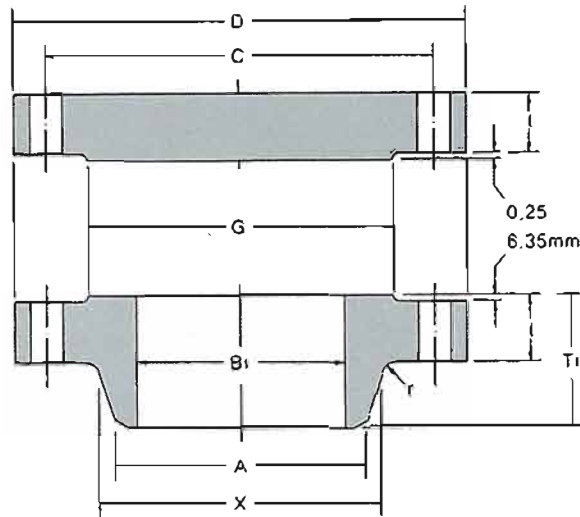

CLASS 400 FLANGES

ASME B16.47 SER.B(API 605)

Unit:mm

Nominal Pipe Size	Outside Diam.	O.D of Raised Face	Diam. of Hub at Base	Diam. of Hub at Bevel	BORE			Length Thru Hub	THICKNESS		Radius at Base of Hub	DRILLING			Approximate Weight(kg)	
					Wall Thickness				Blind	Welding		Bolt Circle Diam	Number of Holes	Diam. of Holes	Welding neck	Blind
					6.35mm	9.5mm	12.7mm									
D	G	X	A	B1			T1	t	t	r	c					
26	850.9	711.2	688.8	660.4	647.7	641.4	635.0	149.4	88.9	88.9	11.2	781.1	28	38.1	163.3	396.4
28	914.4	762.0	739.6	711.2	698.5	692.2	685.8	158.8	95.3	95.3	12.7	838.2	24	41.1	204.1	490.3
30	971.6	819.2	793.8	762.0	749.3	743.0	736.6	169.9	101.6	101.6	12.7	895.4	28	41.1	240.4	590.6
32	1035.1	873.3	844.8	812.8	800.1	793.8	787.4	179.3	108.0	108.0	12.7	952.5	28	44.5	288.0	712.2
34	1085.9	927.1	898.7	863.6	850.9	844.6	838.2	187.5	111.3	111.3	14.2	1003.3	32	44.5	313.0	807.9
36	1155.7	980.9	952.5	914.4	901.7	895.4	889.0	200.2	119.1	119.1	14.2	1066.8	28	47.8	387.8	979.8
38	1206.5	1035.1	1003.3	965.2	952.5	946.2	939.8	206.2	124.0	124.0	14.2	1117.6	32	47.8	424.1	1111.3
40	1270.0	1092.2	1054.1	1016.0	1003.3	997.0	990.6	215.9	130.0	130.0	14.2	1174.8	32	50.8	494.4	1291.9
42	1320.8	1143.0	1107.9	1066.8	1054.1	1047.8	1041.4	223.8	133.4	133.4	14.2	1225.6	32	50.8	539.8	1432.9
44	1384.3	1200.2	1158.7	1117.6	1104.9	1098.6	1092.2	233.2	139.7	139.7	14.2	1282.7	32	53.8	623.7	1648.8
46	1441.5	1257.3	1212.9	1168.4	1155.7	1149.4	1143.0	244.3	146.1	146.1	14.2	1339.9	36	53.8	691.7	1868.8
48	1511.3	1308.1	1267.0	1219.2	1206.5	1200.2	1193.8	257.0	152.4	152.4	14.2	1403.4	28	60.5	811.9	2143.7
50	1568.5	1361.9	1320.8	1270.0	1257.3	1251.0	1244.6	268.2	158.8	157.2	14.2	1460.5	32	60.5	884.5	2405.4
52	1619.3	1412.7	1371.6	1320.8	1308.1	1301.8	1295.4	276.4	163.8	162.1	14.2	1511.3	32	60.5	963.9	2641.3
54	1701.8	1470.2	1425.4	1371.6	1358.9	1352.6	1346.2	289.1	171.5	169.9	14.2	1581.2	28	66.5	1163.5	3058.2
56	1752.6	1527.0	1479.6	1422.4	1409.7	1403.4	1397.0	298.5	176.3	174.8	14.2	1632.0	32	66.5	1229.3	3334.9
58	1803.4	1577.8	1530.4	1473.2	1460.5	1454.2	1447.8	306.3	180.8	177.8	14.2	1682.8	32	66.5	1465.1	3622.4
60	1886.0	1635.3	1584.5	1524.0	1511.3	1505.0	1498.6	319.0	189.0	185.7	14.2	1752.6	32	73.2	1732.8	4139.6

Notes

Dimensions for class 600,900 NPS 36" and larger as the same as for series A flanges.

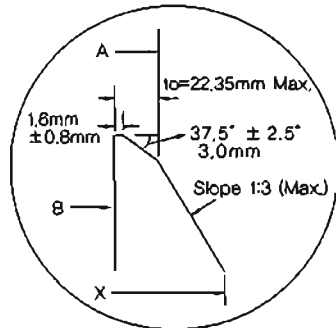

BEVEL FOR WALL THICKNESS(t_o)
0.88" IN.(22.35mm) OR LESS.

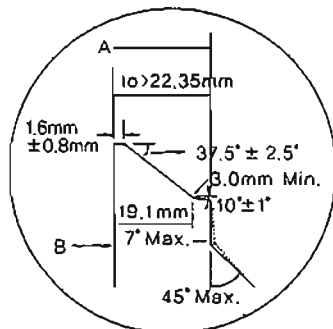

BEVEL FOR WALL THICKNESS(t_o)
GREATER THAN 0.88 IN.(22.35mm)

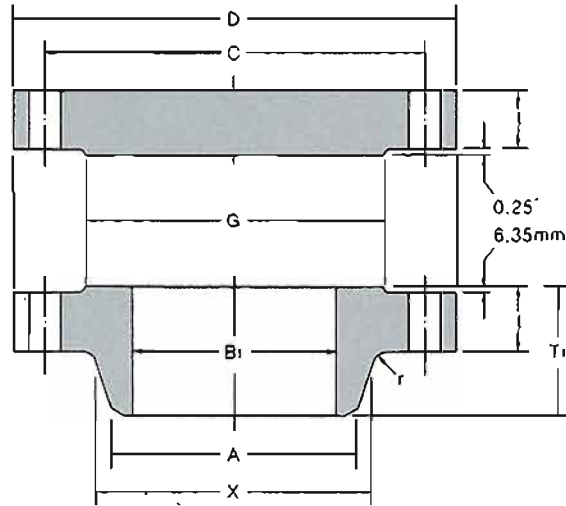

CLASS 600 FLANGES

ASME B16.47 SER.B(API 605)

Unit:mm

Nominal Pipe Size	Outside Diam.	O.D of Raised Face	Diam. of Hub at Base	Diam. of Hub at Bevel	BORE			Length Thru Hub	THICKNESS		Radius at Base of Hub	DRILLING			Approximate Weight(kg)	
					Wall Thickness				Blind	Welding Neck		Bolt Circle Diam	Number of Holes	Diam. of Holes	Welding neck	Blind
					6.35mm	9.5mm	12.7mm									
D	G	X	A	B1			T1	t	t	r	c					
26	889.0	726.9	698.5	660.4	647.7	641.4	635.0	180.8	111.3	111.3	12.70	806.5	28	44.5	249.5	541.6
28	952.5	784.4	752.3	711.2	698.5	692.2	685.8	190.5	115.8	115.8	12.70	863.6	28	47.8	294.8	647.3
30	1022.4	841.2	806.5	762.0	749.3	743.0	736.6	204.7	127.0	125.5	12.70	927.1	28	50.8	367.4	817.4
32	1085.9	895.4	860.6	812.8	800.1	793.8	787.4	215.9	134.9	130.0	12.70	984.3	28	53.8	430.9	979.3
34	1162.1	952.5	914.4	863.6	850.9	844.6	838.2	233.4	144.3	141.2	14.22	1054.1	24	60.5	546.6	1199.8
36	1212.9	1009.7	968.2	914.4	901.7	895.4	889.0	242.8	150.9	146.1	14.22	1104.9	28	60.5	607.8	1366.7
38	1270.0	1054.1	1022.4	965.2	952.5	946.2	939.8	254.0	155.4	152.4	14.22	1162.3	28	60.5	666.8	1544.1
40	1320.8	1111.3	1073.2	1016.0	1003.3	997.0	990.6	263.7	162.1	158.8	14.22	1212.9	32	60.5	739.4	1740.9
42	1403.4	1168.4	1127.3	1066.8	1054.1	1047.8	1041.4	279.4	171.5	168.1	14.22	1282.7	28	66.5	920.8	2079.8
44	1454.2	1225.6	1181.1	1117.6	1104.9	1098.6	1092.2	289.1	177.8	173.0	14.22	1333.5	32	66.5	979.8	2315.6
46	1511.3	1276.4	1234.9	1168.4	1155.7	1149.4	1143.0	300.0	185.7	179.3	14.22	1390.7	32	66.5	1093.2	2611.8
48	1593.9	1333.5	1289.1	1219.2	1206.5	1200.2	1193.8	316.0	195.3	189.0	14.22	1460.5	32	73.2	1295.0	3055.9
50	1670.1	1384.3	1343.2	1270.0	1257.3	1251.0	1244.6	328.7	203.2	196.9	14.22	1524.0	28	79.2	1510.5	3490.5
52	1720.9	1435.1	1394.0	1320.8	1308.1	1301.8	1295.4	336.6	209.6	203.2	14.22	1574.8	32	79.2	1614.8	3822.0
54	1778.0	1492.3	1447.8	1371.6	1358.9	1352.6	1346.2	349.3	217.4	209.6	14.22	1632.0	32	79.2	1778.1	4233.4
56	1854.2	1543.1	1501.6	1422.4	1409.7	1403.4	1397.0	362.0	225.6	217.4	15.75	1695.5	32	85.9	1941.4	4776.0
58	1905.0	1600.2	1552.4	1473.2	1460.5	1454.2	1447.8	369.8	231.6	222.3	15.75	1746.3	32	85.9	2104.7	5177.4
60	1993.9	1657.4	1609.9	1524.0	1511.3	1505.0	1498.6	388.9	242.8	233.4	17.53	1822.5	28	91.9	2268.0	5945.8

Notes

Dimensions for class 600,900 NPS 36" --and larger as the same as for series A flanges.

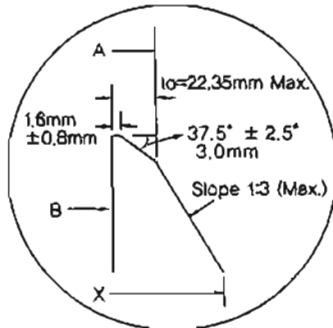

BEVEL FOR WALL THICKNESS(t_o)
0.88" IN.(22.35mm) OR LESS.

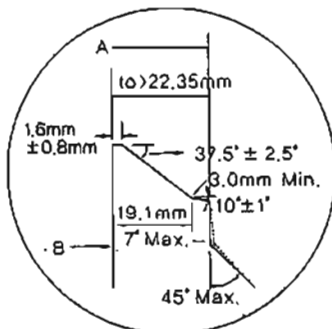

BEVEL FOR WALL THICKNESS(t_o)
GREATER THAN 0.88 IN.(22.35mm)

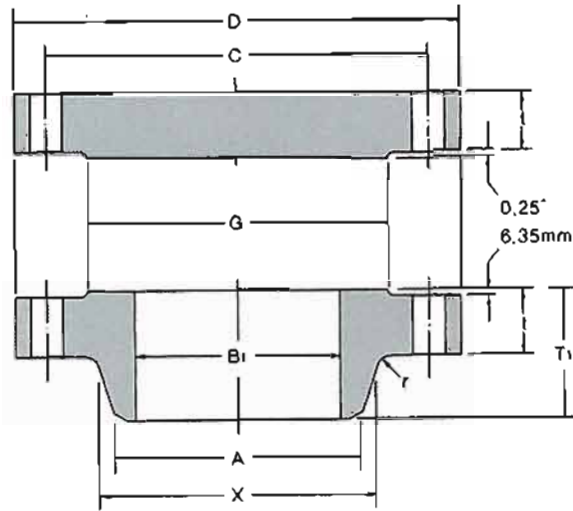

CLASS 900 FLANGES

ASME B16.47 SER.B(API 605)

Unit:mm

Nominal Pipe Size	Outside Diam.	O.D of Raised Face	Diam. of Hub at Base	Diam. of Hub at Bevel	BORE			Length Thru Hub	THICKNESS		Radius at Base of Hub	DRILLING			Approximate Weight(kg)	
					Wall Thickness				Blind	Welding		Bolt Circle Diam	Number of Holes	Diam. of Holes	Welding neck	Blind
					6.35mm	9.5mm	12.7mm									
D	G	X	A	B1			T1	t	t	r	c					
26	1022.4	762.0	743.0	660.4	647.7	641.4	635.0	258.8	153.9	134.9	11.2	901.7	20	66.5	476.3	990.7
28	1104.9	819.2	797.1	711.2	698.5	692.2	685.8	276.4	166.6	147.6	12.7	971.6	20	73.2	689.5	1252.8
30	1181.1	876.3	850.9	762.0	749.3	743.0	736.6	289.1	176.0	155.4	12.7	1035.1	20	79.2	825.6	1512.3
32	1238.3	927.1	908.1	812.8	800.1	793.8	787.4	303.3	185.7	160.3	12.7	1092.2	20	79.2	936.7	1753.2
34	1314.5	990.6	962.2	863.6	850.9	844.6	838.2	319.0	195.1	171.5	14.2	1155.7	20	85.9	1111.3	2075.7
36	1346.2	1028.7	1016.0	914.4	901.7	895.4	889.0	325.4	201.7	173.0	14.2	1200.2	24	79.2	1143.1	2251.2
38	1460.5	1098.6	1073.2	965.2	952.5	946.2	939.8	352.6	215.9	190.5	19.1	1289.1	20	91.9	1535.4	2836.4
40	1511.3	1162.1	1127.3	1016.0	1003.3	997.0	990.6	363.5	223.8	196.9	20.6	1339.9	24	91.9	1642.0	3148.0
42	1562.1	1212.9	1176.3	1066.8	1054.1	1047.8	1041.4	371.3	231.6	206.2	20.6	1390.7	24	91.9	1796.3	3481.4
44	1648.0	1270.0	1234.9	1117.6	1104.9	1098.6	1092.2	390.7	242.8	214.4	22.4	1463.5	24	98.6	1950.5	4061.5
46	1733.6	1333.5	1292.4	1168.4	1155.7	1149.4	1143.0	411.0	255.5	225.6	22.4	1536.7	24	104.6	2104.7	4729.2
48	1784.4	1384.3	1343.2	1219.2	1206.5	1200.2	1193.8	419.1	263.7	233.4	23.9	1587.5	24	104.6	2258.9	5170.1

Notes

Dimensions for class 600,900 NPS 36" –and larger as the same as for series A flanges.

FINISH & TOLERANCE

ANSI B16.47 SER.B Forged Flanges

1. Standard Finishes for Contact Face of Flanges

The flange face shall have a serrated finish consisting of 20 to 40 grooves per inch, 0.002 in. to 0.005 in. deep, cut spirally or concentrically with a round-nose tool.

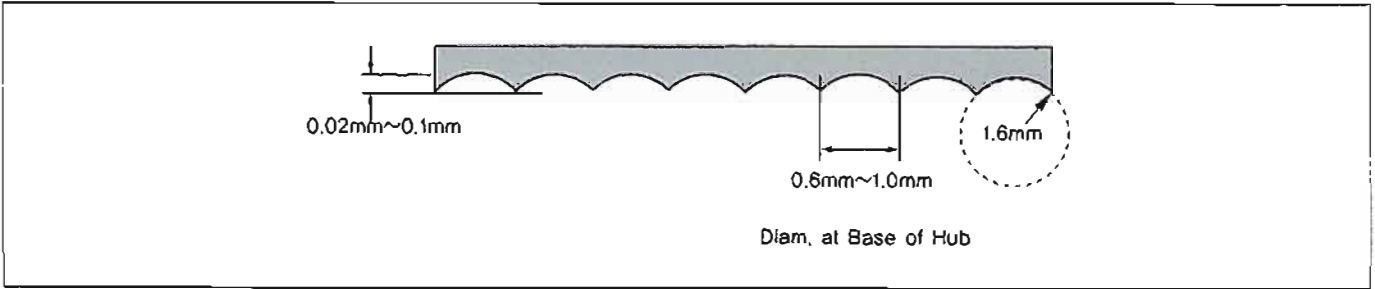

2. Dimensional Tolerances for ASME B16.47 SER. B Flanges.

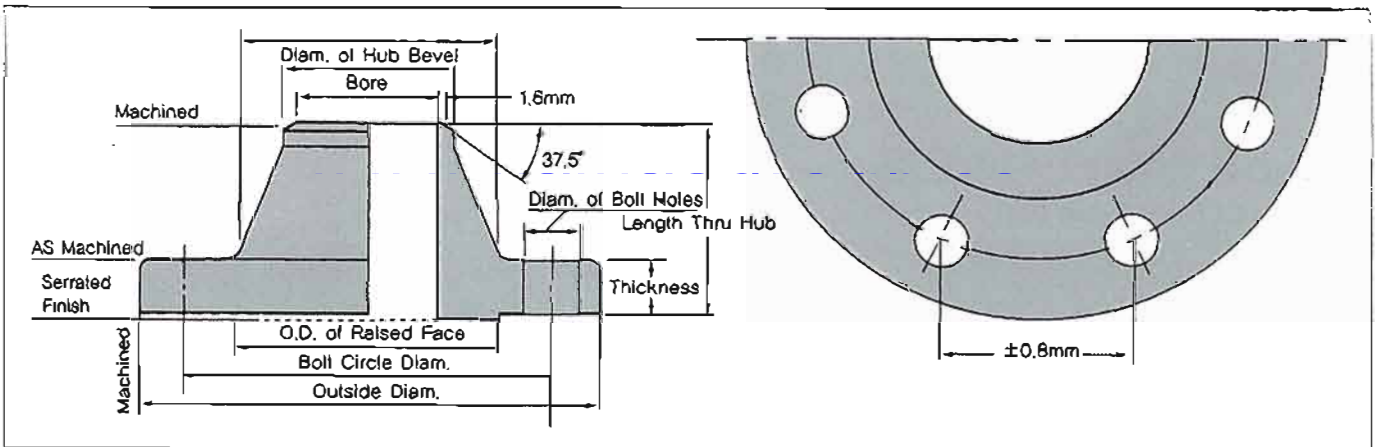

Dimension	Tolerance
outside diameter of raised face	± 0.8mm
Flange thickness	+ 4.8mm, - 0mm
Length thru hub	± 3.0mm
Diam. of hub at bevel	+ 4.1mm, - 0.8mm
Bolt circle diameter	± 1.6mm
Center-to-center of adjacent bolt holes	± 0.8mm
Bore	+ 3.0mm, - 1.6mm
Outside diameter	± 3.0mm
Diameter at base of hub	± 3.0mm

Notes

(1) Flanges shall have bearing surfaces for bolting that are parallel to the flange face within 1 degree. Any back facing or spot facing required to accomplish parallelism between the flange face and nut bearing surface on the back of the flange shall not reduce the flange thickness.

(2) Tolerance for the welding end of a welding neck flange shall be in conformance with ANSI B16.25.

(3) Other tolerances than specified the table shall be in accordance with ANSI B16.5.

(4) The flange shall be either back-faced or spot-faced at the bolt-holes on the flange back if the nut bearing surface at the back of the flange is not parallel with the flange face within the tolerances listed in Note, if the fillet at the hub interferes with the nut bearing surface or if the flange thickness exceed the minimum required thickness by more than 0.19 inch (4.8 millimeters). The nut bearing surface is the spot-facing diameter at the bolt-holes as given in MSS SP-9. Spot-facing shall be in accordance with MSS SP-9.

(5) Tolerances marked * are not covered in API 605.

MATERIAL SPECIFICATIONS

A. MATERIALS

- a. The Steel used in the manufacture of these flanges shall be selected to meet the following requirements.
- b. The F48 and higher grades of Class 400, 600 and 900 flanges shall be killed steel.
- c. The steel used shall be suitable for field welding to other flanges fittings, or pipe manufactured under ASTM specifications A105, A53, A106, A381 or API Standards 5L and 5LX.
- d. The steel used shall have a maximum carbon content of 0.35 and a carbon equivalent computed by the following equation.

$$C_E = C + \frac{Mn}{6} + \frac{Si+Cr+Mo}{5} + \frac{Ni+Cu}{15}$$

that should not exceed 50%, based on check analysis, if the carbon equivalent factor exceeds 0.50%, the acceptance of the flanges shall be based on agreement of customer.

- e. The choice and used of alloying elements, combined with the elements within the limits prescribed in paragraph A. d. to give the required tensile properties prescribed in paragraph A. f. shall be made by AJF. and reported in the chemical analysis to identify the type of steel.
- f. The steel used shall have tensile properties conforming to the requirements prescribed in following table.

B. HEAT TREATMENT

The F42 and higher grades of flanges of all pressure classes and the class 400 and higher classes of Grade F36 flanges shall be normalized or quenched and tempered.

C. TEST SPECIMEN

The test specimens may be taken from the forgings or, at the manufactures option, from the billets or forging bar entering into the finished product, provided such test blank has undergone relatively the same forming and the equivalent heat treatment as the finished flange. The dimensions of the test blank must be such as to adequately reflect the heat treatment properties of the hub of the flange.

MSS SP44 FORGED FLANGES

Grade	Yield Point Min.		Tensile Strength Min.		Elongation in 2 in. Min Recent
	KSI	Mpa	KSI	Mpa	
F36	36	248	60	414	20
F42	42	290	60	414	20
F46	46	317	60	414	20
F48	48	331	62	427	20
F50	50	345	64	441	20
F52	52	359	66	455	20
F56	56	388	68	469	20
F60	60	414	75	517	20
F65	65	448	77	531	18

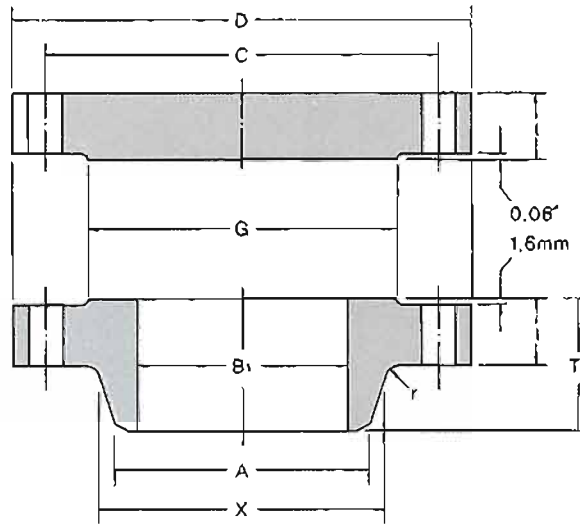

CLASS 150 FLANGES

ASME B16.47 SER.A(MSS SP 44)

Unit:mm

Nominal Pipe Size	Outside Diam.	O.D of Raised Face	Diam. at Base of Hub	Thickness	BORE		Length Thru Hub
					Wall Thickness		
					9.5mm	12.7mm	
	D	G	X	t	B1		T1
12	483	381.0	365.3	31.8	304.8	298.5	114.3
14	533	412.8	400.1	35.1	336.6	330.2	127.0
16	597	469.9	457.2	36.6	387.4	381.0	127.0
18	635	533.4	505.0	39.6	438.2	431.8	139.7
20	699	584.2	558.8	42.9	489.0	482.6	144.5
22	749	641.4	609.6	46.0	539.8	533.4	149.4
24	813	692.2	663.4	47.8	590.6	584.2	152.4
26	870	749.3	676.1	68.3	641.4	635.0	120.7
28	927	800.1	726.9	71.4	692.2	685.8	125.5
30	984	857.3	781.1	74.7	743.0	736.6	136.7
32	1060	914.4	831.9	80.8	793.8	787.4	144.5
34	1111	965.2	882.7	82.6	844.6	838.2	149.4
36	1168	1022.4	933.5	90.4	895.4	889.0	157.0
38	1238	1073.2	990.6	87.4	946.2	939.8	157.2
40	1289	1124.0	1041.4	90.4	997.0	990.6	163.6
42	1346	1193.8	1092.2	96.8	1047.8	1041.4	171.5
44	1403	1244.6	1143.0	101.6	1098.6	1092.2	177.8
46	1454	1295.4	1196.8	103.1	1149.4	1143.0	185.7
48	1511	1358.9	1247.6	108.0	1200.2	1193.8	192.0
50	1568	1409.7	1301.8	111.3	1251.0	1244.6	203.2
52	1626	1460.5	1352.6	115.8	1301.8	1295.4	209.6
54	1683	1511.3	1403.4	120.7	1352.6	1346.2	215.9
56	1746	1574.8	1457.5	124.0	1403.4	1397.0	228.6
58	1803	1625.6	1508.3	128.5	1454.2	1447.8	235.0
60	1854	1676.4	1559.1	131.8	1505.0	1498.6	239.8

Notes

- (1) For the 'Bore' (B1) other than wall thickness 0.375" (9.5mm) and 0.500" (12.7mm), refer to page 83
- (2) Class 150 flanges will be furnished with 0.06" (1.6mm) raised face, which is included in 'Thickness' (t) and 'Length thru Hub' (T1).
- (3) Dimensional tolerance are in accordance with ANSI B16.5.

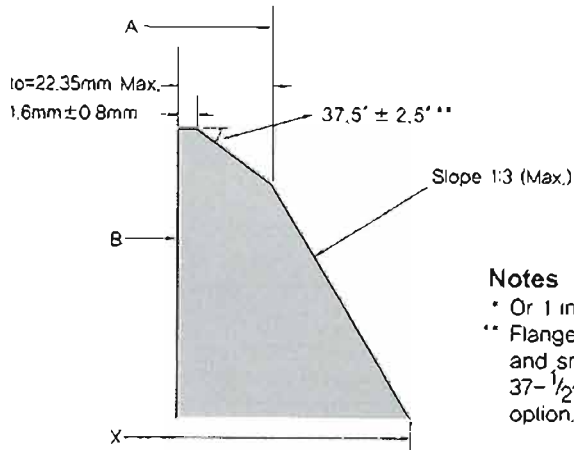

BEVEL FOR WALL THICKNESS(t_o)
0.88" IN.(22.35mm) OR LESS.

Notes

- * Or 1 inch at manufacturer's option
- ** Flanges sizes 24" (609.6mm) and smaller may be furnished with 37-1/2° bevel at manufacturer's option.

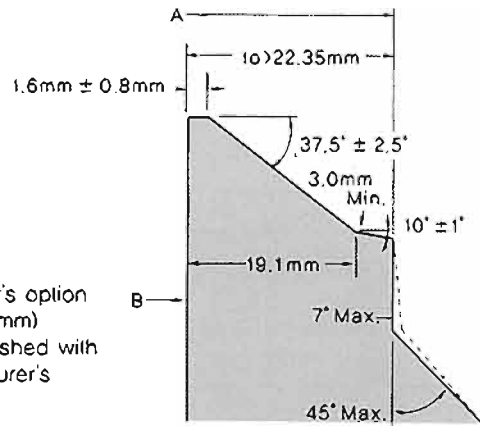

BEVEL FOR WALL THICKNESS(t_o)
GREATER THAN 0.88 IN.(22.35mm)

WELDING-ENDS FOR WELDING-NECK FLANGES

Unit:mm

Nominal Pipe Size	Diam. of Hub Bevel	Radius of Fillet	DRILLING			Approximate Weight(kg)	
			Bolt Circle Diam	Number of Holes	Diam of Holes	Weld-neck	Blind
			C				
A	r	C					
12	304.8	9.7	431.8	12	25.4	38.98	43.70
14	355.6	9.7	476.3	12	28.4	51.71	59.42
16	406.4	9.7	539.8	16	28.4	64.41	77.11
18	457.2	9.7	577.9	16	31.8	74.84	94.80
20	508.0	9.7	635.0	20	31.8	89.36	123.38
22	558.8	9.7	692.2	20	35.1	112.00	-
24	609.6	9.7	749.3	20	35.1	119.66	188.24
26	660.4	9.7	806.5	24	35.1	138.10	318.40
28	711.2	11.2	863.6	28	35.1	156.50	377.80
30	762.0	11.2	914.4	28	35.1	181.40	445.40
32	812.8	11.2	977.9	28	41.1	229.10	561.10
34	863.6	12.7	1028.7	32	41.1	244.90	627.80
36	914.4	12.7	1085.9	32	41.1	290.30	760.20
38	965.2	12.7	1149.4	32	41.1	326.60	825.10
40	1016.0	12.7	1200.2	36	41.1	351.50	925.30
42	1066.8	12.7	1257.3	36	41.1	403.70	1080.00
44	1117.6	12.7	1314.5	40	41.1	449.10	1232.40
46	1168.4	12.7	1365.3	40	41.1	480.80	1343.10
48	1219.2	12.7	1422.4	44	41.1	537.50	1518.70
50	1270.0	12.7	1479.6	44	47.8	576.10	1685.60
52	1320.8	12.7	1536.7	44	47.8	639.60	1885.20
54	1371.6	12.7	1593.9	44	47.8	719.00	2104.30
56	1422.4	12.7	1651.0	48	47.8	798.30	2327.90
58	1473.2	12.7	1708.2	48	47.8	868.60	2574.20
60	1524.0	12.7	1759.0	52	47.8	927.60	2791.50

(4) Maximum Pressure Rating for raised face flanges is 285 psi (19.5BARS) at atmospheric temperature.

(5) Flange dimendlons of size 12" (304.8mm) through 24" (609.6mm) flanges except 22" (558.8mm) are in accordance with ANSI B 16.5.

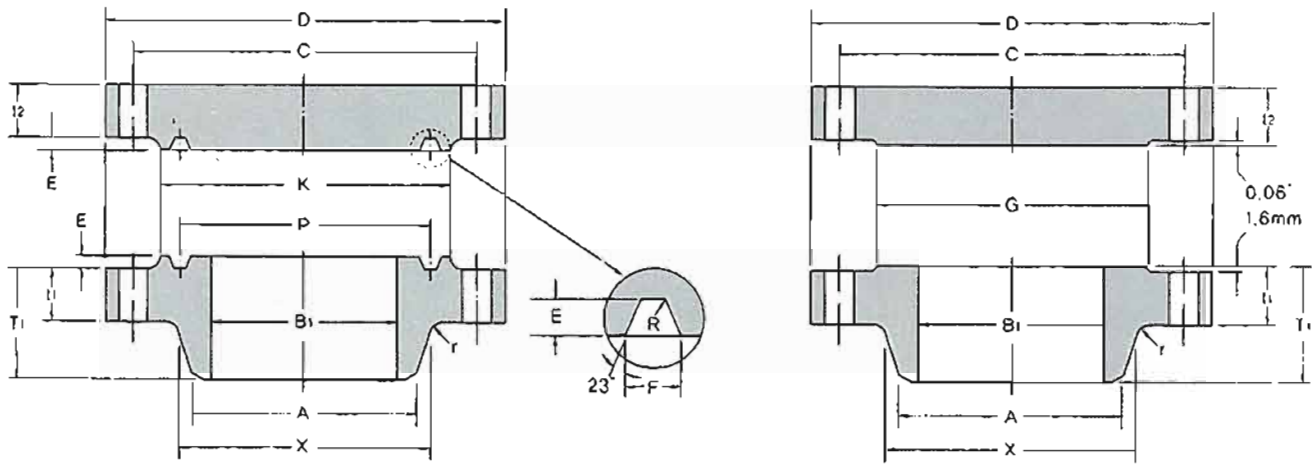

CLASS 300 FLANGES

ASME B16.47 SER.A(MSS SP 44)

Unit:mm

Nominal Pipe Size	Outside Diam.	O.D of Raised Face	Diam. at Base of Hub	Thickness		BORE		Length Thru Hub	Diam. of Hub at Bevel	Radius of Fillet
						Wall Thickness				
						9.5mm	12.7mm			
D	G	X	t1	t2	B1	T1	A	r		
12	521	381.0	374.7	50.8	50.8	304.8	298.5	130.0	304.8	9.7
14	584	412.8	425.5	53.8	53.8	336.6	330.2	142.7	355.6	9.7
16	648	469.9	482.6	57.2	57.2	387.4	381.0	146.1	406.4	9.7
18	711	533.4	533.4	60.5	60.5	468.2	431.8	158.8	457.2	9.7
20	775	584.2	587.2	63.5	63.5	489.0	482.6	162.1	508.0	9.7
22	838	641.4	641.4	66.5	66.5	539.8	533.4	165.1	558.8	9.7
24	914	692.2	701.5	69.9	69.9	590.6	584.2	168.1	609.6	9.7
26	972	749.3	720.9	79.2	84.1	641.4	635.0	184.2	660.4	9.7
28	1035	800.1	774.7	85.9	90.4	692.2	685.8	196.9	711.2	11.2
30	1092	857.3	827.0	91.9	95.3	743.0	736.6	209.6	762.0	11.2
32	1149	914.4	881.1	98.6	100.1	793.8	787.4	222.3	812.8	11.2
34	1207	965.2	936.8	101.6	104.6	844.6	838.2	231.6	863.6	12.7
36	1270	1022.4	990.6	104.6	111.3	895.4	889.0	241.3	914.4	12.7
38	1168	1028.7	993.6	108.0	108.0	946.2	939.8	180.8	965.2	12.7
40	1238	1085.9	1047.8	114.3	114.3	997.0	990.6	193.5	1016.0	12.7
42	1289	1136.7	1098.6	119.1	119.1	1047.8	1041.4	200.2	1066.8	12.7
44	1353	1193.8	1149.4	124.0	124.0	1098.6	1092.2	206.2	1117.6	12.7
46	1416	1244.6	1203.5	128.5	128.5	1149.4	1143.0	215.9	1168.4	12.7
48	1467	1301.8	1254.3	133.4	133.4	1200.2	1193.8	223.8	1219.2	12.7
50	1530	1358.9	1305.1	139.7	139.7	1251.0	1244.6	231.6	1270.0	12.7
52	1581	1409.7	1355.9	144.5	144.5	1301.8	1295.4	238.3	1320.8	12.7
54	1657	1466.9	1409.7	152.4	152.4	1352.6	1346.2	252.5	1371.6	12.7
56	1708	1517.7	1463.5	153.9	153.9	1403.4	1397.0	260.4	1422.4	12.7
58	1759	1574.8	1514.3	158.8	158.8	1454.2	1447.8	266.7	1473.2	12.7
60	1810	1625.6	1565.1	163.6	163.6	1505.0	1498.6	273.1	1524.0	12.7

Notes

- (1) For the 'Bore' (B1) other than wall thickness 0.375" (9.5mm) and 0.500" (12.7mm), refer to page 83.
- (2) Class 300 flanges will be furnished with 0.06" (1.6mm) raised face, which is included in 'Thickness' (t) and 'Length thru Hub' (T1).
- (3) Dimensional tolerance are in accordance with ASME B 16.5.

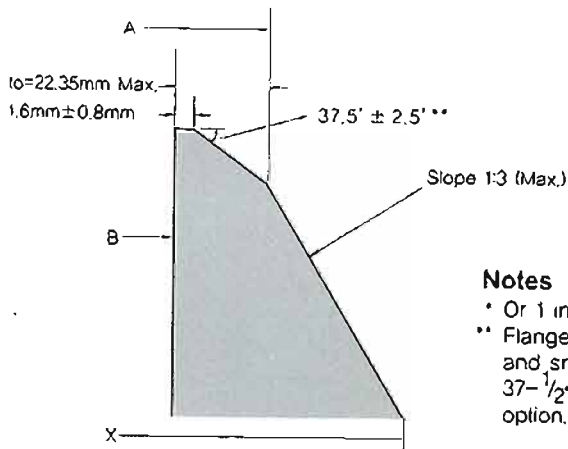

BEVEL FOR WALL THICKNESS(t_o)
0.88" IN.(22.35mm) OR LESS.

Notes

- * Or 1 inch at manufacturer's option
- ** Flanges sizes 24" (609.6mm) and smaller may be furnished with 37- $\frac{1}{2}$ ° bevel at manufacturer's option.

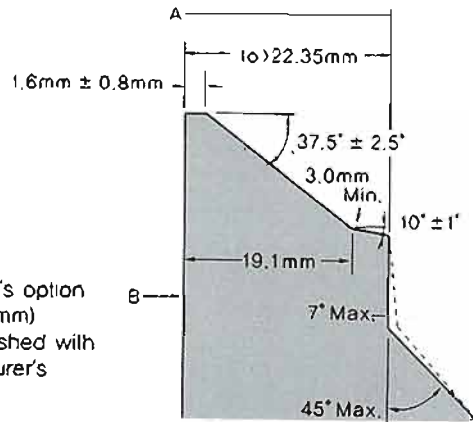

BEVEL FOR WALL THICKNESS(t_o)
GREATER THAN 0.88 IN.(22.35mm)

WELDING-ENDS FOR WELDING-NECK FLANGES

Unit:mm

Nominal Pipe Size	DRILLING			Pitch Dima	GROOVE DIMENSIONS			Diam. of Raised Face	Ring and Groove Number	Approximate Weight(kg)	
	Bolt Circle Diam	Number of Holes	Diam of Holes		Width	Depth	Radius			Weld-neck	Blind
12	450.9	16	31.8	381.0	11.9	7.9	0.8	412.8	R57	64.41	78.90
14	514.4	20	31.8	419.1	11.9	7.9	0.8	457.2	R61	88.30	107.05
16	571.5	20	35.1	469.9	11.9	7.9	0.8	508.0	R65	112.94	139.25
18	628.7	24	35.1	533.4	11.9	7.9	0.8	574.5	R69	138.34	176.90
20	685.8	24	35.1	584.2	13.5	9.5	1.5	635.0	R73	167.37	223.17
22	743.0	24	41.1	635.0	15.1	11.1	1.5	685.8	R81	213.00	-
24	812.8	24	41.1	692.2	16.7	11.1	1.5	749.3	R77	235.41	342.00
26	876.3	28	44.5	749.3	19.8	12.7	1.5	809.8	R93	274.40	489.00
28	939.8	28	44.5	800.1	19.8	12.7	1.5	860.6	R94	337.90	596.50
30	997.0	28	47.8	857.3	19.8	12.7	1.5	917.4	R95	394.60	699.90
32	1054.1	28	50.8	914.4	23.0	14.3	1.5	984.3	R96	455.90	814.20
34	1104.9	28	50.8	965.2	23.0	14.3	1.5	1035.1	R97	519.40	938.00
36	1168.4	32	53.8	1022.4	23.0	14.3	1.5	1092.2	R98	578.30	1105.00
38	1092.2	32	41.1							315.30	907.70
40	1155.7	32	44.5							381.00	1079.60
42	1208.5	32	44.5							430.90	1219.30
44	1263.7	32	47.8							478.50	1396.60
46	1320.8	28	50.8							560.20	1587.10
48	1371.6	32	50.8							626.00	1767.20
50	1428.8	32	53.8							694.00	2014.90
52	1479.6	32	53.8							753.00	2225.40
54	1549.4	28	60.5							928.90	2578.30
56	1600.2	28	60.5							977.50	2766.10
58	1651.0	32	60.5							1029.70	3025.10
60	1701.8	32	60.5							1120.40	3299.50

(4) Maximum Pressure Rating for raised face flanges is 740 psi (51BARS) at atmospheric temperature.

(5) Flange dimendions of size 12" (304.8mm) through 24" (609.6mm) flanges except 22" (558.8mm) are in accordance with ASME B 16.5.

(6) For sizes 26" (660.4mm) and larger. Diameter of Hub at Bevel (A) are in accordance with ASME Boiler and pressure vessel code.

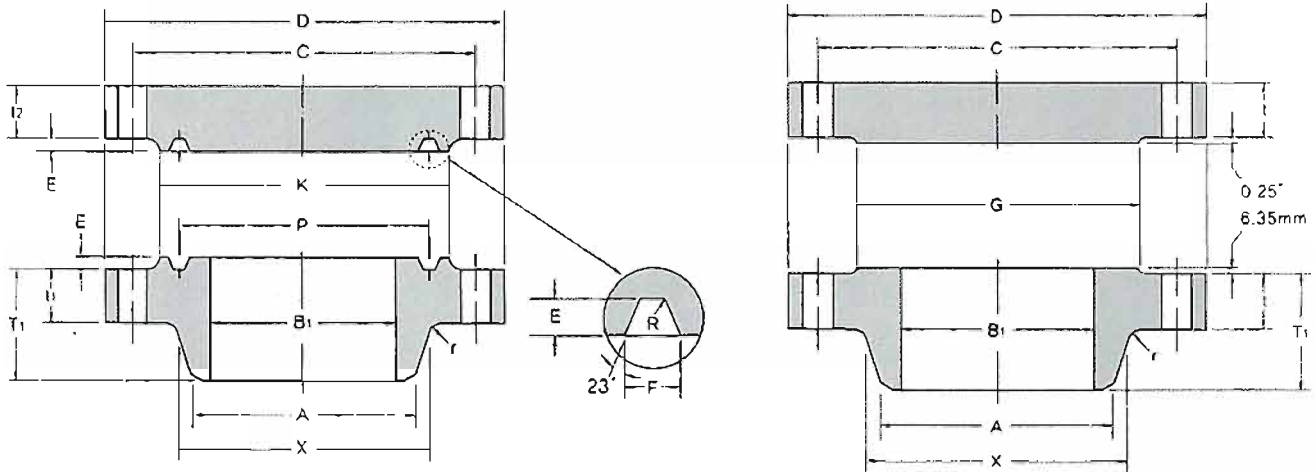

CLASS 400 FLANGES

ASME B16.47 SER.A (MSS SP 44)

Unit:mm

Nominal Pipe Size	Outside Diam.	O.D of Raised Face	Diam. at Base of Hub	Thickness		BORE		Length Thru Hub	Diam. of Hub at Bevel	Radius of Fillet
						Wall Thickness				
						9.5mm	12.7mm			
D	G	X	t1	t2	B1	T1	A	r		
12	521	381.0	374.7	57.2	57.2	304.8	298.5	136.7	323.9	11.2
14	584	412.8	425.5	60.5	60.5	336.6	330.2	149.4	355.6	11.2
16	648	469.9	482.6	63.5	63.5	387.4	381.0	152.4	406.4	11.2
18	711	533.4	533.4	66.5	66.5	438.2	431.8	165.1	457.2	11.2
20	775	584.2	587.2	69.9	69.9	489.0	482.6	168.1	508.0	11.2
22	838	641.4	641.4	73.2	73.2	539.8	533.4	171.5	558.8	11.2
24	914	692.2	701.5	76.2	76.2	590.6	584.2	174.8	609.6	11.2
26	972	749.3	726.9	88.9	98.6	641.4	635.0	193.5	660.4	11.2
28	1035	800.1	782.6	95.3	104.6	692.2	685.8	206.2	711.2	12.7
30	1092	857.3	836.7	101.6	111.3	743.0	736.6	218.9	762.0	12.7
32	1149	914.4	889.0	108.0	115.8	793.8	787.4	231.6	812.8	12.7
34	1207	965.2	944.6	111.3	122.2	844.6	838.2	241.3	863.6	14.2
36	1270	1022.4	1000.3	114.3	128.5	895.4	889.0	251.0	914.4	14.2
38	1207	1035.1	1003.3	124.0	124.0	946.2	939.8	206.2	965.2	14.2
40	1270	1092.2	1054.1	130.0	130.0	997.0	990.6	215.9	1016.0	14.2
42	1321	1143.0	1107.9	133.4	133.4	1047.8	1041.4	223.8	1066.8	14.2
44	1384	1200.2	1158.7	139.7	139.7	1098.6	1092.2	233.4	1117.6	14.2
46	1441	1257.3	1212.9	146.1	146.1	1149.4	1143.0	244.3	1168.4	14.2
48	1511	1308.1	1267.0	152.4	152.4	1200.2	1193.8	257.0	1219.2	14.2
50	1568	1361.9	1320.8	157.2	158.8	1251.0	1244.6	268.2	1270.0	14.2
52	1619	1412.7	1371.6	162.1	163.6	1301.8	1295.4	276.4	1320.8	14.2
54	1702	1470.2	1425.4	169.9	171.5	1352.6	1346.2	289.1	1371.6	14.2
56	1753	1527.0	1479.6	174.8	176.3	1403.4	1397.0	298.5	1422.4	14.2
58	1803	1577.8	1530.4	177.8	180.8	1454.2	1447.8	306.3	1473.2	14.2
60	1886	1635.3	1584.5	185.7	189.0	1505.0	1498.6	319.0	1524.0	14.2

Notes

- (1) For the 'Bore' (B1) other than wall thickness 0.375" (9.5mm) and 0.500" (12.7mm), refer to page 83.
- (2) Class 400 flanges will be furnished with 0.25" (6.4mm) raised face, which is included in 'Thickness' (t) and 'Length thru Hub' (T1).
- (3) Dimensional tolerance are in accordance with ASME B 16.5.

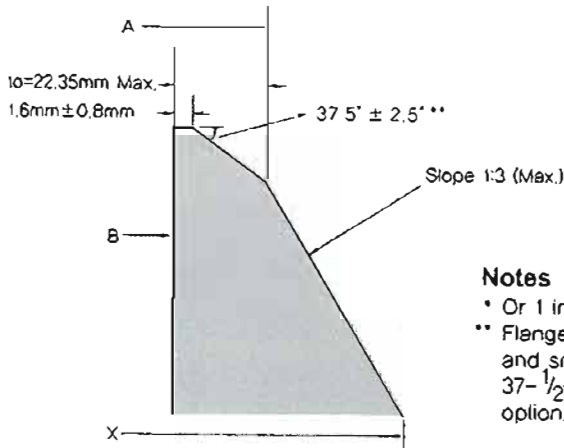

BEVEL FOR WALL THICKNESS(t_o)
0.88" IN.(22.35mm) OR LESS.

Notes

- Or 1 inch at manufacturer's option
- ** Flanges sizes 24" (609.6mm) and smaller may be furnished with 37-1/2° bevel at manufacturer's option.

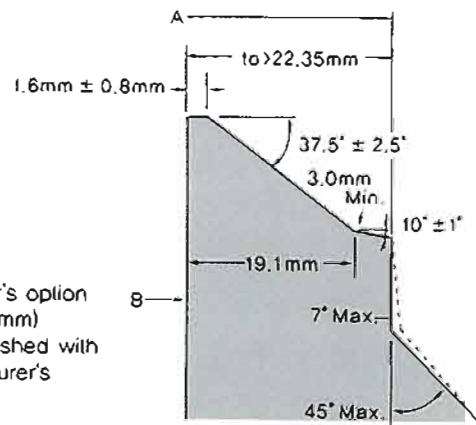

BEVEL FOR WALL THICKNESS(t_o)
GREATER THAN 0.88 IN.(22.35mm)

WELDING-ENDS FOR WELDING-NECK FLANGES

Unit:mm

Nominal Pipe Size	DRILLING			Pitch Dima	GROOVE DIMENSIONS			Diam. of Raised Face	Ring and Groove Number	Approximate Weight(kg)	
	Bolt Circle Diam	Number of Holes	Diam of Holes		Width	Depth	Radius			Weld-neck	Blind
12	450.9	16	35.1	381.0	11.9	7.9	0.8	412.8	R57	72.57	98.00
14	514.4	20	35.1	419.1	11.9	7.9	0.8	457.2	R61	105.69	131.66
16	571.5	20	38.1	469.9	11.9	7.9	0.8	508.0	R65	133.30	167.00
18	628.7	24	38.1	533.4	11.9	7.9	0.8	574.5	R69	158.90	206.57
20	685.8	24	41.1	584.2	13.5	9.5	1.5	635.0	R73	193.00	261.00
22	743.0	24	44.5	635.0	15.1	11.1	1.5	685.8	R81	235.00	-
24	812.8	24	47.8	692.2	16.7	11.1	1.5	749.3	R77	281.48	395.00
26	876.3	28	47.8	749.3	19.8	12.7	1.5	809.8	R93	294.80	572.90
28	939.8	28	50.8	800.1	19.8	12.7	1.5	860.6	R94	356.10	690.40
30	997.0	28	53.8	857.3	19.8	12.7	1.5	917.4	R95	410.50	817.40
32	1054.1	28	53.8	914.4	23.0	14.3	1.5	984.3	R96	483.10	942.10
34	1104.9	28	53.8	965.2	23.0	14.3	1.5	1035.1	R97	544.30	1095.40
36	1168.4	32	53.8	1022.4	23.0	14.3	1.5	1092.2	R98	607.80	1276.90
38	1117.6	32	47.8							424.10	1111.30
40	1174.8	32	50.8							494.40	1291.90
42	1225.6	32	50.8							539.80	1432.90
44	1282.7	32	53.8							623.70	1648.80
46	1339.9	36	53.8							691.70	1868.80
48	1403.4	28	60.5							811.90	2143.70
50	1460.5	32	60.5							884.50	2405.40
52	1511.3	32	60.5							963.90	2641.30
54	1581.2	28	66.5							1163.50	3058.20
56	1632.0	32	66.5							1229.30	3334.90
58	1682.8	32	66.5							1465.10	3622.40
60	1752.6	32	73.2							1732.80	4139.60

(4) Maximum Pressure Rating for raised face flanges is 985 psi (68BARS) at atmospheric temperature.

(5) Flange dimensions of size 12" (304.8mm) through 24" (609.6mm) flanges except 22" (558.8mm) are in accordance with ASME B 16.5.

(6) For sizes 26" (660.4mm) and larger. Diameter of Hub at Bevel (A) are in accordance with ASME Boiler and pressure vessel code.

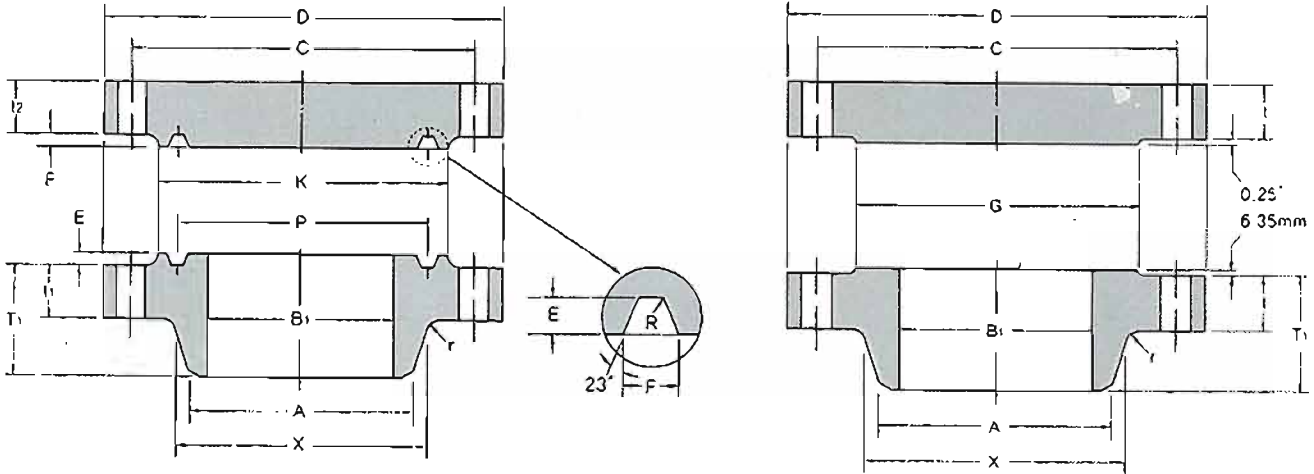

CLASS 600 FLANGES

ASME B16.47 SER.A(MSS SP 44)

Unit:mm

Nominal Pipe Size	Outside Diam.	O.D of Raised Face	Diam. at Base of Hub	Thickness		BORE		Length Thru Hub	Diam. of Hub at Bevel	Radius of Fillet
						Wall Thickness				
						9.5mm	12.7mm			
D	G	X	t1	t2	B1		T1	A	r	
12	559	381.0	400.1	66.5	66.5	304.8	298.5	155.4	323.9	11.2
14	603	412.8	431.8	69.9	69.9	336.6	330.2	165.1	355.6	11.2
16	686	469.9	495.3	76.2	76.2	387.4	381.0	177.8	406.4	11.2
18	743	533.4	546.1	82.6	82.6	438.2	431.8	184.2	457.2	11.2
20	813	584.2	609.6	88.9	88.9	489.0	482.6	190.5	508.0	11.2
22	870	641.2	666.8	95.3	95.3	539.8	533.4	196.9	558.8	11.2
24	940	692.2	717.6	101.6	101.6	590.6	584.2	203.2	609.6	11.2
26	1016	749.3	747.8	108.0	125.5	641.4	635.0	222.3	660.4	12.7
28	1073	800.1	803.1	111.3	131.8	692.2	685.8	235.0	711.2	12.7
30	1130	857.3	862.1	114.3	139.7	743.0	736.6	247.7	762.0	12.7
32	1194	914.4	917.4	117.3	147.6	793.8	787.4	260.4	812.8	12.7
34	1245	965.2	973.1	120.7	153.9	844.6	838.2	269.7	863.6	14.2
36	1314	1022.4	1031.7	124.0	162.1	895.4	889.0	282.4	914.4	14.2
38	1270	1054.1	1022.4	152.4	155.4	946.2	939.8	254.0	965.2	14.2
40	1321	1111.3	1073.2	158.8	162.1	997.0	990.6	263.7	1016.0	14.2
42	1403	1168.4	1127.3	168.1	171.5	1047.8	1041.4	279.4	1066.8	14.2
44	1454	1225.6	1181.1	173.0	177.8	1098.6	1092.2	289.1	1117.6	14.2
46	1511	1276.4	1234.9	179.3	185.7	1149.4	1143.0	300.0	1168.4	14.2
48	1594	1333.5	1289.1	189.0	195.3	1200.2	1193.8	316.0	1219.2	14.2
50	1670	1384.3	1343.2	196.9	203.2	1251.0	1244.6	328.7	1270.0	14.2
52	1721	1435.1	1394.0	203.2	209.6	1301.8	1295.4	336.6	1320.8	14.2
54	1778	1492.3	1447.8	209.6	217.4	1352.6	1346.2	349.3	1371.6	14.2
56	1854	1543.1	1501.6	217.4	225.8	1403.4	1397.0	362.0	1422.4	15.7
58	1905	1600.2	1552.4	222.3	231.6	1454.2	1447.8	369.8	1473.2	15.7
60	1994	1657.4	1609.9	233.4	242.8	1505.0	1498.6	388.9	1524.0	17.5

Notes

- (1) For the 'Bore' (B1) other than wall thickness 0.375" (9.5mm) and 0.500" (12.7mm), refer to page 50, 51.
- (2) Class 600 flanges will be furnished with 0.25" (6.35mm) raised face, which is included in 'Thickness' (t) and 'Length thru Hub' (T1).
- (3) Dimensional tolerance are in accordance with ASME B 16.5.

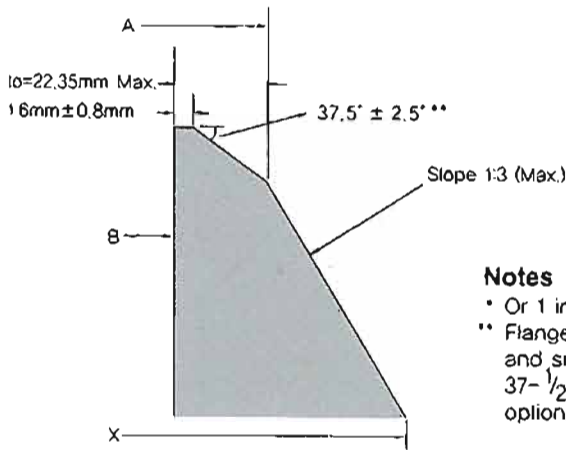

BEVEL FOR WALL THICKNESS(t_o)
0.88" IN.(22.35mm) OR LESS.

Notes

- Or 1 inch at manufacturer's option
- ** Flanges sizes 24" (609.6mm) and smaller may be furnished with 37-1/2° bevel at manufacturer's option.

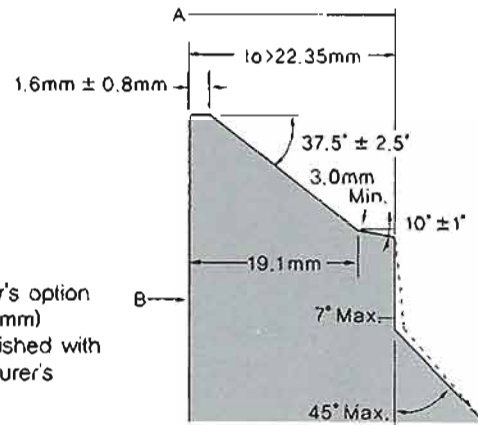

BEVEL FOR WALL THICKNESS(t_o)
GREATER THAN 0.88 IN.(22.35mm)

WELDING-ENDS FOR WELDING-NECK FLANGES

Unit:mm

Nominal Pipe Size	DRILLING			Pitch Dima	GROOVE DIMENSIONS			Diam. of Raised Face	Ring and Groove Number	Approximate Weight(kg)	
	Bolt Circle Diam	Number of Holes	Diam of Holes		Width	Depth	Radius			Weld-neck	Blind
12	489.0	20	35.1	381.0	11.9	7.9	0.8	412.8	R57	102.51	132.00
14	527.1	20	38.1	419.1	11.9	7.9	0.8	457.2	R61	121.56	158.00
16	603.3	20	41.1	469.9	11.9	7.9	0.8	508.0	R65	177.06	224.73
18	654.1	20	44.5	533.4	11.9	7.9	0.8	574.5	R69	215.65	285.00
20	723.9	24	44.5	584.2	13.5	9.5	1.5	635.0	R73	267.86	365.00
22	777.7	24	47.8	635.0	15.1	11.1	1.5	685.8	R81	330.00	-
24	838.2	24	50.8	692.2	16.7	11.1	1.5	749.3	R77	372.00	533.45
26	914.4	28	50.8	749.3	19.8	12.7	1.5	809.8	R93	426.40	797.90
28	965.2	28	53.8	800.1	19.8	12.7	1.5	860.6	R94	480.80	934.90
30	1022.4	28	53.8	857.3	19.8	12.7	1.5	917.4	R95	548.90	1099.10
32	1079.5	28	60.5	914.4	23.0	14.3	1.5	984.3	R96	623.70	1295.50
34	1130.3	28	60.5	965.2	23.0	14.3	1.5	1035.1	R97	698.50	1468.30
36	1193.8	28	66.5	1022.4	23.0	14.3	1.5	1092.2	R98	773.40	1724.60
38	1162.1	28	60.5							666.80	1544.10
40	1212.9	32	60.5							739.40	1740.90
42	1282.7	28	66.5							920.80	2079.80
44	1333.5	32	66.5							979.80	2315.60
46	1390.7	32	66.5							1093.20	2611.80
48	1460.5	32	73.2							1295.00	3055.90
50	1524.0	28	79.2							1510.50	3490.50
52	1574.8	32	79.2							1614.80	3822.00
54	1632.0	32	79.2							1778.10	4233.40
56	1695.5	32	85.9							1941.40	4776.00
58	1746.3	32	85.9							2104.70	5177.40
60	1822.5	28	91.9							2268.00	5945.80

(4) Maximum Pressure Rating for raised face flanges is 1480 psi (102.1 BARS) at atmospheric temperature.

(5) Flange dimensions of size 12" (304.8mm) through 24" (609.6mm) flanges except 22" (558.8mm) are in accordance with ASME B 16.5.

(6) For sizes 26" (660.4mm) and larger. Diameter of Hub at Bevel (A) are in accordance with ASME Boiler and pressure vessel code.

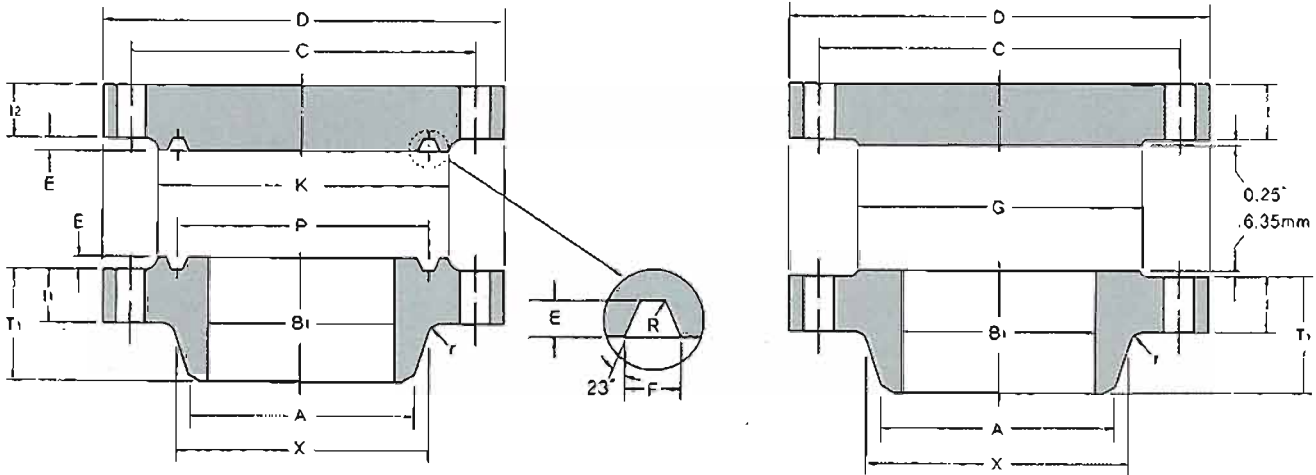

CLASS 900 FLANGES

ASME B16.47 SER.A(MSS SP 44)

Unit:mm

Nominal Pipe Size	Outside Diam.	O.D of Raised Face	Diam. at Base of Hub	Thickness		BORE		Length Thru Hub	Diam. of Hub at Bevel	Radius of Fillet
				Welding Neck	Blind	Wall Thickness				
						9.5mm	12.7mm			
D	G	X	t1	t2	B1		T1	A	r	
12	610	381.0	419.1	79.2	79.2	304.8	298.5	200.2	323.9	11.2
14	641	412.8	450.9	85.9	85.9	336.6	330.2	212.9	355.6	11.2
16	705	469.9	508.0	88.9	88.9	387.4	381.0	215.9	406.4	11.2
18	787	533.4	565.2	101.6	101.6	438.2	431.8	228.6	457.2	11.2
20	857	584.2	622.3	108.0	108.0	489.0	482.6	247.7	508.0	11.2
24	1041	692.2	749.3	139.7	139.7	590.6	584.2	292.1	609.6	11.2
26	1086	749.3	774.7	139.7	160.3	641.4	635.0	285.8	660.4	11.2
28	1168	800.1	831.9	142.7	171.5	692.2	685.8	298.5	711.2	12.7
30	1232	857.3	889.0	149.4	182.4	743.0	736.6	311.2	762.0	12.7
32	1314	914.4	946.2	158.8	193.5	793.8	787.4	330.2	812.8	12.7
34	1397	965.2	1006.3	165.1	204.7	844.6	838.2	349.3	863.6	14.2
36	1461	1022.4	1063.8	171.5	214.4	895.4	889.0	362.0	914.4	14.2
38	1461	1098.6	1073.2	190.5	215.9	946.2	939.8	352.6	965.2	19.1
40	1511	1162.1	1127.3	196.9	223.8	997.0	990.6	363.5	1016.0	20.6
42	1562	1212.9	1176.3	206.2	231.6	1047.8	1041.4	371.3	1066.8	20.6
44	1648	1270.0	1234.9	214.4	242.8	1098.6	1092.2	390.7	1117.6	22.4
46	1734	1333.5	1292.4	225.6	255.5	1149.4	1143.0	411.0	1168.4	22.4
48	1784	1384.3	1343.2	233.4	263.7	1200.2	1193.8	419.1	1219.2	23.9

Notes

- (1) For the 'Bore' (B1) other than wall thickness 0.375" (9.5mm) and 0.500" (12.7mm), refer to page 83.
- (2) Class 900 flanges will be furnished with 0.25" (6.35mm) raised face, which is included in 'Thickness' (t) and 'Length thru Hub' (T1).
- (3) Dimensional tolerance are in accordance with ASME B 16.5.

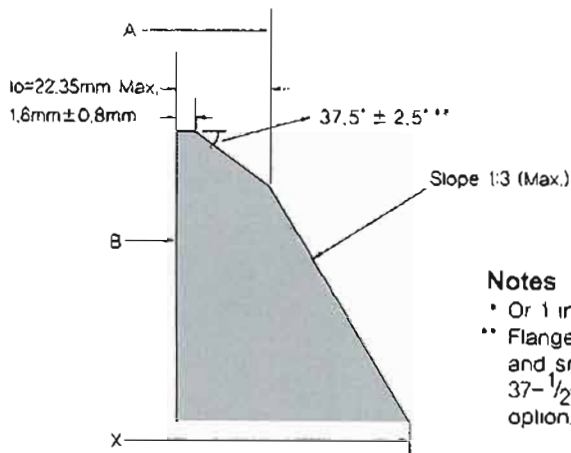

BEVEL FOR WALL THICKNESS(t_o)
0.88" IN.(22.35mm) OR LESS.

Notes

- * Or 1 inch at manufacturer's option
- ** Flanges sizes 24" (609.6mm) and smaller may be furnished with 37-1/2° bevel at manufacturer's option.

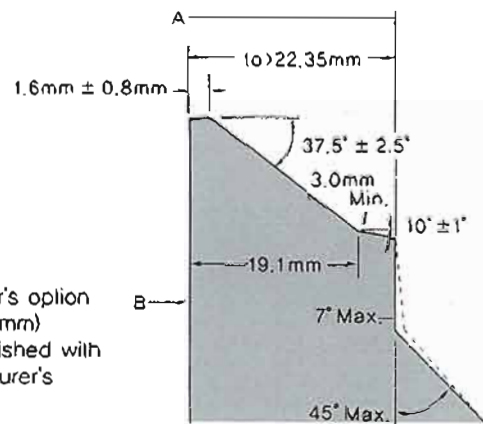

BEVEL FOR WALL THICKNESS(t_o)
GREATER THAN 0.88 IN.(22.35mm)

WELDING-ENDS FOR WELDING-NECK FLANGES

Unit:mm

Nominal Pipe Size	DRILLING			Pitch Dima	GROOVE DIMENSIONS			Diam. of Raised Face	Ring and Groove Number	Approximate Weight(kg)	
	Bolt Circle Diam	Number of Holes	Diam of Holes		Width	Depth	Radius			Weld-neck	Blind
12	533.4	20	38.1	381.0	11.9	7.9	0.8	419.1	R57	157.00	187.00
14	558.8	20	41.1	419.1	16.7	11.1	1.5	466.9	R62	181.00	224.07
16	616.0	20	44.5	469.9	16.7	11.1	1.5	523.7	R66	224.73	272.40
18	685.8	20	50.8	533.4	19.8	12.7	1.5	593.9	R70	308.72	385.90
20	749.3	20	53.8	584.2	19.8	12.7	1.5	647.7	R74	376.82	488.00
24	901.7	20	66.5	692.2	27.0	15.9	2.3	771.7	R78	685.00	905.00
26	952.5	20	73.2	749.3	30.2	17.5	2.3	831.9	R100	691.70	1163.90
28	1022.4	20	79.2	800.1	33.3	17.5	2.3	889.0	R101	821.00	1441.50
30	1085.9	20	79.2	857.3	33.3	17.5	2.3	946.2	R102	961.60	1704.60
32	1155.7	20	85.9	914.4	33.3	17.5	2.3	1003.3	R103	1154.40	2059.80
34	1225.6	20	91.9	965.2	36.5	20.6	2.3	1066.8	R104	1347.20	2460.80
36	1289.1	20	91.9	1022.4	36.5	20.6	2.3	1124.0	R105	1540.00	2816.40
38	1289.1	20	91.9							1535.40	2836.40
40	1339.9	24	91.9							1642.00	3148.00
42	1390.7	24	91.9							1796.30	3481.40
44	1463.5	24	98.6							1950.50	4061.50
46	1536.7	24	104.6							2104.70	4729.20
48	1587.5	24	104.6							2258.90	5170.10

(4) Maximum Pressure Rating for raised face flanges is 2220 psi (153.1 BARS) at atmospheric temperature.

(5) Flange dimensions of size 12" (304.8mm) through 24" (609.6mm) flanges are in accordance with ASME B 16.5.

(6) For sizes 26" (660.4mm) and larger, Diameter of Hub at Bevel (A) are in accordance with ASME Boiler and pressure vessel code.



AWWA C207-07 –Rings & Blinds.
CLASS B

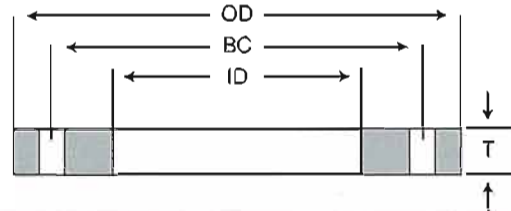

Nominal Size	Outside Diameter (OD)	Slip-on Bore (ID)	NO. of Bolt Holes	Diameter Bolt Holes	Bolt Circle (BC)	Thickness (T)		Weight Each	
						CLASS B			
						Slip-on	Blind	Slip-on	Blind
4	228.6	116.1	8	19.1	190.5	15.9	15.9	3.52	4.84
5	254	143.8	8	22.2	215.9	15.9	15.9	3.91	5.94
6	279.4	170.7	8	22.2	241.3	17.5	17.5	4.86	8
8	342.9	221.5	8	22.2	298.5	17.5	17.5	6.97	12.27
10	406.4	276.4	12	25.4	362	17.5	17.5	8.75	17
12	482.6	327.2	12	25.4	431.8	17.5	18.3	12.75	25.42
14	533.4	360.4	12	28.6	476.3	17.5	20.1	15.64	34.07
16	596.9	411.2	16	28.6	539.8	17.5	22.7	18.8	48.07
18	635	462	16	31.8	577.9	17.5	24.1	18.74	57.55
20	698.5	512.8	20	31.8	635	17.5	26.4	22.1	76.18
22	749.3	563.6	20	34.9	692.2	19.1	28.8	25.86	95.44
24	812.8	614.4	20	34.9	749.3	19.1	30.9	30.5	121.31
26	869.95	666.8	24	34.9	808.5	20.6	33.2	35.96	149.04
28	927.1	717.6	28	34.9	863.3	22.2	35.5	42.52	180.79
30	984.25	768.4	28	34.9	914.4	22.2	37.5	47.15	216.25
32	1060.5	819.2	28	41.3	977.9	23.8	40.2	59.59	267.11
34	1111.3	870	32	41.3	1028.7	23.8	42.2	62.19	307.35
36	1168.4	920.8	32	41.3	1085.9	25.4	44.5	72.51	359.84
38	1238.3	971.6	32	41.3	1149.4	25.4	47.1	83.81	429.75
40	1289.1	1022.4	36	41.3	1200.2	25.4	49.1	86.99	484.83
42	1346.2	1073.2	36	41.3	1257.3	28.6	51.4	105.72	555.26
44	1403.4	1124	40	41.3	1314.5	28.6	53.7	112.57	629.96
48	1511.3	1225.6	44	41.3	1422.4	31.8	58	138.69	790.5
54	1682.8	1378	44	47.6	1593.9	34.9	65	179.42	1095.72
60	1854.2	1530.4	52	47.6	1759	38.1	71.6	229.93	1466.79
66	2032	1682.8	52	47.6	1930.4	41.3	78.5	300.53	1942.81
72	2197.1	1835.2	60	47.6	2095.5	44.5	85.2	363.34	2466.14
78	2362.2	1987.6	64	54	2260.6	50.8		452.23	
84	2533.7	2140	64	54	2425.7	50.8		518.24	
90	2705.1	2292.4	68	61.9	2590.8	57.2		635.94	
96	2876.6	2444.8	68	61.9	2755.9	57.2		718.99	
102	3048	2597.2	72	68.3	2908.3	63.5		865.47	
108	3219.5	2749.6	72	68.3	3067.1	63.5		967.34	
120	3562.4	3054.4	76	74.6	3371.9	69.9		1267.3	
132	3905.3	3359.2	80	81	3702.1	76.2		1618.4	
144	4248.2	3664	84	87.3	4019.6	82.6		2029.5	

AWWA C207-07 –Rings & Blinds. CLASS D

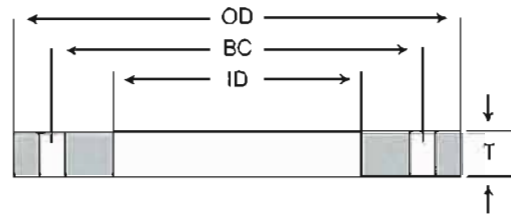

Nominal Size	Outside Diameter (OD)	Slip-on Bore (ID)	NO. of Bolt Holes	Diameter Bolt Holes	Bolt Circle (BC)	Thickness (T)		Weight Each	
						CLASS D			
						Slip-on	Blind	Slip-on	Blind
4	228.6	116.1	8	19.1	190.5	15.9	15.9	3.52	4.84
5	254	143.8	8	22.2	215.9	15.9	16.5	3.91	6.17
6	279.4	170.7	8	22.2	241.3	17.5	17.6	4.86	8.05
8	342.9	221.5	8	22.2	298.5	17.5	20.6	6.97	14.44
10	406.4	276.4	12	25.4	362	17.5	24.2	8.75	23.5
12	482.6	327.2	12	25.4	431.8	20.6	28.4	15.01	39.45
14	533.4	360.4	12	28.6	476.3	23.8	28.8	21.27	48.81
16	596.9	411.2	16	28.6	539.8	25.4	32.1	27.29	67.97
18	635	462	16	31.8	577.9	27	33.8	28.92	80.72
20	698.5	512.8	20	31.8	635	28.6	36.8	36.12	106.19
22	749.3	563.6	20	34.9	692.2	30.2	39.8	40.89	131.89
24	812.8	614.4	20	34.9	749.3	31.8	42.2	50.78	165.67
26	869.95	666.8	24	34.9	806.5	33.3	45.4	58.14	203.81
28	927.1	717.6	28	34.9	863.3	33.3	48.4	63.79	246.49
30	984.25	768.4	28	34.9	914.4	34.9	51	74.12	294.1
32	1060.5	819.2	28	41.3	977.9	38.1	54.6	95.4	362.79
34	1111.3	870	32	41.3	1028.7	38.1	57.2	99.56	416.59
36	1168.4	920.8	32	41.3	1085.9	41.3	60.2	117.91	486.79
38	1238.3	971.6	32	41.3	1149.4	41.3	63.7	136.28	581.21
40	1289.1	1022.4	36	41.3	1200.2	41.3	66.3	141.44	654.67
42	1346.2	1073.2	36	41.3	1257.3	44.5	69.3	164.49	748.63
44	1403.4	1124	40	41.3	1314.5	44.5	72.4	175.15	849.33
48	1511.3	1225.6	44	41.3	1422.4	47.6	78	207.61	1063.09
54	1682.8	1378	44	47.6	1593.9	54	87.2	277.62	1469.95
60	1854.2	1530.4	52	47.6	1759	57.2	96	345.2	1966.64
66	2032	1682.8	52	47.6	1930.4	63.5	105	462.08	2598.66
72	2197.1	1835.2	60	47.6	2095.5	66.7	114	544.61	3299.77
78	2362.2	1987.6	64	54	2260.6	69.9		622.26	
84	2533.7	2140	64	54	2425.7	73		744.71	
90	2705.1	2292.4	68	61.9	2590.8	76.2		847.18	
96	2876.6	2444.8	68	61.9	2755.9	82.6		1038.26	
102	3048	2597.2	72	68.3	2908.3	82.6		1125.79	
108	3219.5	2749.6	72	68.3	3067.1	85.7		1305.53	
120	3562.4	3054.4	76	74.6	3371.9	88.9		1611.74	
132	3905.3	3359.2	80	81	3702.1	98.4		2089.89	
144	4248.2	3664	84	87.3	4019.6	105		2579.82	



河北海浩

EN 1092-1:2007 PN6.....	71-72
EN 1092-1:2007 PN10.....	73-74
EN 1092-1:2007 PN16.....	75-76
EN 1092-1:2007 PN25.....	77-78
EN 1092-1:2007 PN40.....	79-80



欧标
法兰参数系列



EN 1092-1:2007

DIMENSIONS OF PN6 FLANGES

TYPE 01

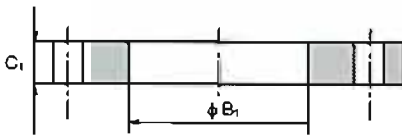

TYPE 02

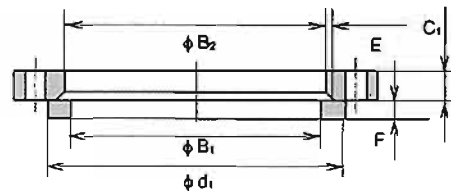

TYPE 05

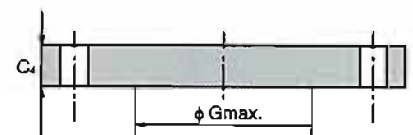

DN	Outside diameter	Diameter of bolt circle	Diameter of bolt hole	Bolt number	Outside diameter of neck A	Bore diameters		Flange thickness			Chamfer E	Wall thickness S	Collar Thickness F	Diameter of shoulder Gmax
						B ₁	B ₂	C ₁	C ₂	C ₄				
						Flange type								
					11	01	02	01	11	05	02	11	32	05
					01,02,05,11,12,13	12	02	02	12,13					
10	75	50	11	4	17.2	18.0	21	12	12	12	3	2	10	-
15	80	55	11	4	21.3	22.0	25	12	12	12	3	2	10	-
20	90	65	11	4	26.9	27.5	31	14	14	14	4	2.3	10	-
25	100	75	11	4	33.7	34.5	38	14	14	14	4	2.6	10	-
32	120	90	14	4	42.4	43.5	46	16	14	14	5	2.6	10	-
40	130	100	14	4	48.3	49.5	53	16	14	14	5	2.6	10	-
50	140	110	14	4	60.3	61.5	65	16	14	14	5	2.9	12	-
65	160	130	14	4	76.1	77.5	81	16	14	14	6	2.9	12	55
80	190	150	18	4	88.9	90.5	94	18	16	16	6	3.2	12	70
100	210	170	18	4	114.3	116.0	120	18	16	16	6	3.6	14	90
125	240	200	18	8	139.7	141.5	145	20	18	18	6	4.0	14	115
150	265	225	18	8	168.3	170.5	174	20	18	18	6	4.5	14	140
200	320	280	18	8	219.1	221.5	226	22	20	20	6	6.3	16	190
250	375	335	18	12	273.0	276.5	281	24	22	22	8	6.3	18	235
300	440	395	22	12	323.9	327.5	333	24	22	22	8	7.1	18	285
350	490	445	22	12	355.6	359.5	365	26	22	22	8	7.1	18	330
400	540	495	22	16	406.4	411.0	416	28	22	22	8	7.1	20	380
450	595	550	22	16	457.0	462.0	467	30	22	24	8	7.1	20	425
500	645	600	22	20	508.0	513.5	519	30	24	24	8	7.1	22	475
600	755	705	26	20	610.0	616.5	622	32	30	30	8	7.1	22	575
700	860	810	26	24	711.0	To be specified by the purchaser	721	40	30	40	4	8	-	670
800	975	920	30	24	813.0		824	44	30	44	4	8	-	770
900	1075	1020	30	24	914.0		926	48	34	48	4	8	-	860
1000	1175	1120	30	28	1016.0		1028	52	38	52	4	8	-	960
1200	1405	1340	33	32	1219.0		1234	60	42	60	5	8.8	-	1160
1400	1630	1560	36	36	1422		-	72	56	68	-	8.8	-	1346
1600	1830	1760	36	40	1626		-	80	63	76	-	10	-	1546
1800	2045	1970	39	44	1829		-	88	69	84	-	11	-	1746
2000	2265	2180	42	48	2032	-	96	74	92	-	12.5	-	1950	

EN 1092-1:2007

DIMENSIONS OF PN6 FLANGES

TYPE 11

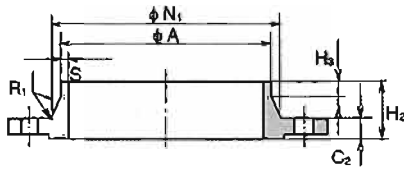

TYPE 12

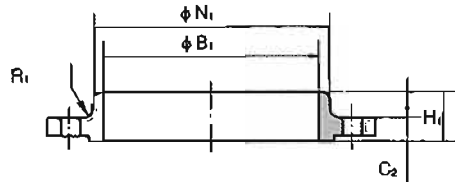

TYPE 13

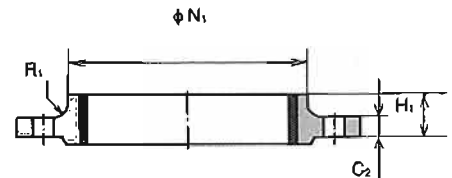

DN	Raised face		Length			Neck diameters		Corner radii	APPROXIMATE WEIGHT				
	d ₁	f ₁	H ₁	H ₂	H ₃	N ₁	N ₂	R ₁	Flange type				
	01,05,11,12,13		12 13	11	11	11	12 13	11 12,13	Type01	Type02	Type05	Type11	Type12
10	35	2	20	28	6	26	25	4	0.356	0.345	0.38	0.353	0.326
15	40	2	20	30	6	30	30	4	0.402	0.388	0.438	0.408	0.373
20	50	2	24	32	6	38	40	4	0.592	0.568	0.657	0.621	0.584
25	60	2	24	35	6	42	50	4	0.719	0.688	0.821	0.762	0.729
32	70	2	26	35	6	55	60	6	1.16	1.12	1.18	1.11	1.04
40	80	3	26	38	7	62	70	6	1.35	1.29	1.39	1.26	1.20
50	90	3	28	38	8	74	80	6	1.48	1.42	1.62	1.43	1.34
65	110	3	32	38	9	88	100	6	1.86	1.76	2.14	1.77	1.83
80	128	3	34	42	10	102	110	8	2.95	2.84	3.43	2.88	2.75
100	148	3	40	45	10	130	130	8	3.26	3.10	4.22	3.41	3.01
125	178	3	44	48	10	155	160	8	4.31	4.12	6.10	4.65	4.30
150	202	3	44	48	12	184	185	10	4.76	4.53	7.51	5.50	4.63
200	258	3	44	55	15	236	240	10	6.88	6.51	12.3	8.60	6.97
250	312	3	44	60	15	290	295	12	8.92	8.32	18.5	11.7	9.13
300	365	4	44	62	15	342	355	12	11.9	11.1	25.5	15.3	12.4
350	415	4	-	62	15	385	-	12	16.8	15.9	31.8	20.3	-
400	465	4	-	65	15	438	-	12	19.8	18.8	38.5	23.1	-
450	520	4	-	65	15	492	-	12	24.6	23.3	51.2	27.0	-
500	570	4	-	68	15	538	-	12	26.4	24.9	60.1	30.8	-
600	670	5	-	70	16	640	-	12	34.8	33.0	103	44.0	-
700	775	5	-	76	16	740	-	12	-	-	178	53.7	-
800	880	5	-	76	16	842	-	12	-	-	252	64.4	-
900	980	5	-	78	16	942	-	12	-	-	336	79.2	-
1000	1080	5	-	82	16	1045	-	16	-	-	435	98.6	-
1200	1295	5	-	104	20	1248	-	16	-	-	717	152	-
1400	1510	5	-	114	20	1452	-	16	-	-	1094	246	-
1600	1710	5	-	119	20	1655	-	16	-	-	1545	309	-
1800	1920	5	-	133	20	1855	-	16	-	-	2131	400	-
2000	2125	5	-	146	25	2058	-	16	-	-	2862	516	-



EN 1092-1:2007

DIMENSIONS OF PN10 FLANGES

TYPE 01

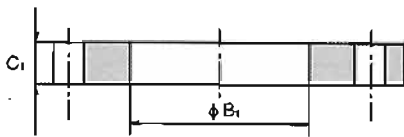

TYPE 02

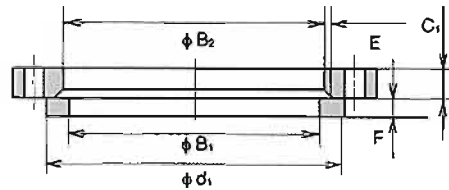

TYPE 05

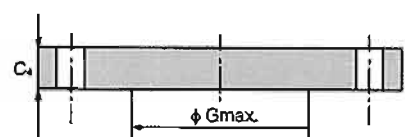

DN	Outside diameter	Diameter of bolt circle	Diameter of bolt hole	Bolt number	Outside diameter of neck A	Bore diameters		Flange thickness			Chamfer E	Wall thickness S	Collar Thickness F	Diameter of shoulder Gmax		
						B ₁	B ₂	C ₁	C ₂	C ₄						
						Flange type										
						01,02,05,11,12,13	11	01,12	02	01,02	11,12,13	05	02	11	32	05
10	90	60	14	4	17.2	18.0	21	14	16	16	3	2	12	-	-	-
15	95	65	14	4	21.3	22.0	25	14	16	16	3	2	12	-	-	-
20	105	75	14	4	26.9	27.5	31	16	18	18	4	2.3	14	-	-	-
25	115	85	14	4	33.7	34.5	38	16	18	18	4	2.6	14	-	-	-
32	140	100	18	4	42.4	43.5	47	18	18	18	5	2.6	14	-	-	-
40	150	110	18	4	48.3	49.5	53	18	18	18	5	2.6	14	-	-	-
50	165	125	18	4	60.3	61.5	65	20	18	18	5	2.9	16	-	-	-
65	185	145	18	8	76.1	77.5	81	20	18	18	6	2.9	16	55	-	-
80	200	160	18	8	88.9	90.5	94	20	20	20	6	3.2	16	70	-	-
100	220	180	18	8	114.3	116.0	120	22	20	20	6	3.6	18	90	-	-
125	250	210	18	8	139.7	141.5	145	22	22	22	6	4.0	18	115	-	-
150	285	240	22	8	168.3	170.5	174	24	22	22	6	4.5	20	140	-	-
200	340	295	22	8	219.1	221.5	226	24	24	24	6	6.3	20	190	-	-
250	395	350	22	12	273.0	276.5	281	26	26	26	8	6.3	22	235	-	-
300	445	400	22	12	323.9	327.5	333	26	26	26	8	7.1	22	285	-	-
350	505	460	22	16	355.6	359.5	365	30	26	26	8	7.1	22	330	-	-
400	565	515	26	16	406.4	411.0	416	32	26	26	8	7.1	24	380	-	-
450	615	565	26	20	457.0	462.0	467	36	28	28	8	7.1	24	425	-	-
500	670	620	26	20	508.0	513.5	519	38	28	28	8	7.1	26	475	-	-
600	780	725	30	20	610.0	616.5	622	42	30	34	8	8.0	26	575	-	-
700	895	840	30	24	711.0		721	50	35	38	8	8.8	-	670	-	-
800	1015	950	33	24	813.0		824	56	38	48	8	8.8	-	770	-	-
900	1115	1050	33	28	914.0		926	62	38	50	8	12.5	-	860	-	-
1000	1230	1160	36	28	1016.0		1028	70	44	54	8	12.5	-	960	-	-
1200	1455	1380	39	32	1219.0		1234	83	55	66	8	12.5	-	1160	-	-
1400	1675	1590	42	36	1422		-	-	65	-	-	14.2	-	-	-	-
1600	1915	1820	48	40	1626		-	-	75	-	-	16	-	-	-	-
1800	2115	2020	48	44	1829		-	-	85	-	-	17.5	-	-	-	-
2000	2325	2230	48	48	2032		-	-	90	-	-	17.5	-	-	-	-

EN 1092-1:2007

DIMENSIONS OF PN10 FLANGES

TYPE 11

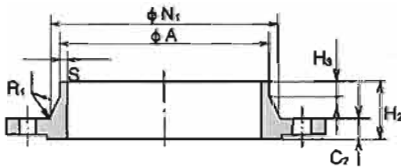

TYPE 12

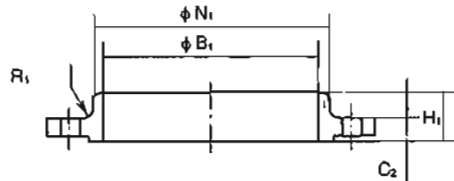

TYPE 13

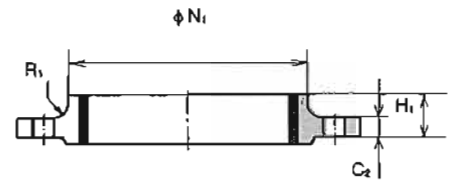

DN	Raised face		Length			Neck diameters		Corner radii	APPROXIMATE WEIGHT				
	d ₁	f ₁	H ₁	H ₂	H ₃	N ₁	N ₂	R ₁	Flange type				
	01,05,11,12,13		12 13	11	11	11	12 13	11 12,13	Type01	Type02	Type05	Type11	Type12
10	40	2	22	35	6	28	30	4	0.604	0.591	0.722	0.678	0.646
15	45	2	22	38	6	32	35	4	0.670	0.654	0.813	0.768	0.722
20	58	2	26	40	6	40	45	4	0.936	0.909	1.14	1.09	1.04
25	68	2	28	40	6	46	52	4	1.11	1.08	1.38	1.30	1.25
32	78	2	30	42	6	56	60	6	1.82	1.77	2.03	1.91	1.81
40	88	3	32	45	7	64	70	6	2.08	2.02	2.35	2.15	2.06
50	102	3	28	45	8	74	84	6	2.73	2.52	2.88	2.53	2.39
65	122	3	32	45	10	92	104	6	3.16	3.05	3.51	3.03	2.97
80	138	3	34	50	10	105	118	6	3.79	3.48	4.61	3.92	3.78
100	158	3	40	52	12	131	140	8	4.39	4.20	5.65	4.62	4.38
125	188	3	44	55	12	156	168	8	5.41	5.21	8.13	6.30	6.07
150	212	3	44	55	12	184	195	10	7.14	6.89	10.5	7.81	7.24
200	268	3	44	62	16	234	246	10	9.27	8.87	16.5	11.6	10.1
250	320	3	46	68	16	292	298	12	11.8	11.2	24.1	15.8	12.8
300	370	4	46	68	16	342	350	12	13.6	12.8	30.8	18.3	14.5
350	430	4	53	68	16	385	400	12	20.4	19.4	39.6	25.3	22.7
400	482	4	57	72	16	440	456	12	27.5	26.4	49.4	30.6	28.0
450	532	4	63	72	16	488	502	12	33.6	32.2	63	35.1	32.3
500	585	4	67	75	16	542	559	12	40.2	38.5	75.2	40.5	38.7
600	685	5	75	82	18	642	658	12	54.5	52.2	124	52.9	48.9
700	800	5	-	85	18	746	-	12	-	79.4	183	75.8	-
800	905	5	-	96	18	850	-	12	-	112	297	102	-
900	1005	5	-	99	20	950	-	12	-	135	374	121	-
1000	1110	5	-	105	20	1052	-	16	-	180	492	161	-
1200	1330	5	-	132	25	1256	-	16	-	278	842	258	-
1400	1535	5	-	143	25	1460	-	16	-	-	-	371	-
1600	1760	5	-	159	25	1666	-	16	-	-	-	547	-
1800	1960	5	-	175	30	1868	-	16	-	-	-	691	-
2000	2170	5	-	186	30	2072	-	16	-	-	-	830	-



EN 1092-1:2007

DIMENSIONS OF PN16 FLANGES

TYPE 01

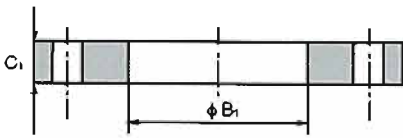

TYPE 02

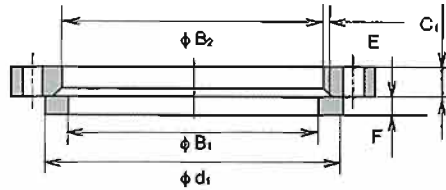

TYPE 05

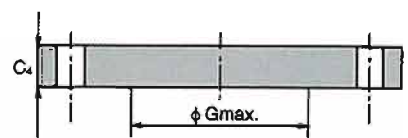

DN	Outside diameter	Diameter of bolt circle	Diameter of bolt hole	Bolt number	Outside diameter of neck A	Bore diameters		Flange thickness			Chamfer E	Wall thickness S	Collar Thickness F	Diameter of shoulder Gmax	
						B ₁	B ₂	C ₁	C ₂	C ₄					
						Flange type									01
						01,02,05,11,12,13									
					11	01	02	01	11	05	02	11	32	05	
					12	12		02	12,13						
10	90	60	14	4	17.2	18.0	21	14	16	16	3	2	12	-	
15	95	65	14	4	21.3	22.0	25	14	16	16	3	2	12	-	
20	105	75	14	4	26.9	27.5	31	16	18	18	4	2.3	14	-	
25	115	85	14	4	33.7	34.5	38	16	18	18	4	2.6	14	-	
32	140	100	18	4	42.4	43.5	47	18	18	18	5	2.6	14	-	
40	150	110	18	4	48.3	49.5	53	18	18	18	5	2.6	14	-	
50	165	125	18	4	60.3	61.5	65	20	18	18	5	2.9	16	-	
65	185	145	18	8	76.1	77.5	81	20	18	18	6	2.9	16	55	
80	200	160	18	8	88.9	90.5	94	20	20	20	6	3.2	16	70	
100	220	180	18	8	114.3	116.0	120	22	20	20	6	3.6	18	90	
125	250	210	18	8	139.7	141.5	145	22	22	22	6	4.0	18	115	
150	285	240	22	8	168.3	170.5	174	24	22	22	6	4.5	20	140	
200	340	295	22	12	219.1	221.5	226	26	24	24	6	6.3	20	190	
250	405	355	26	12	273.0	276.5	281	29	26	26	8	6.3	22	235	
300	460	410	26	12	323.9	327.5	333	32	28	28	8	7.1	24	285	
350	520	470	26	16	355.6	359.5	365	35	30	30	8	8.0	26	330	
400	580	525	30	16	406.4	411.0	416	38	32	32	8	8.0	28	380	
450	640	585	30	20	457.0	462.0	467	42	34	40	8	8.8	30	425	
500	715	650	33	20	508.0	513.5	519	46	38	44	8	8.8	32	475	
600	840	770	36	20	610.0	616.5	622	55	40	54	8	10.0	32	575	
700	910	840	36	24	711.0		721	63	40	58	8	10.0	-	670	
800	1025	950	39	24	813.0		824	74	41	62	8	12.5	-	770	
900	1125	1050	39	28	914.0		926	82	48	64	8	12.5	-	860	
1000	1255	1170	42	28	1016.0		1030	90	59	68	8	12.5	-	960	
1200	1485	1390	48	32	1219		-	-	78	-	-	14.2	-	1160	
1400	1685	1590	48	36	1422		-	-	84	-	-	16	-	1346	
1600	1930	1820	56	40	1626		-	-	102	-	-	17.5	-	1546	
1800	2130	2020	56	44	1829		-	-	110	-	-	20	-	1746	
2000	2345	2230	62	48	2032		-	-	124	-	-	22	-	1950	

EN 1092-1:2007

DIMENSIONS OF PN16 FLANGES

TYPE 11

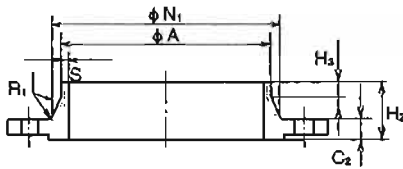

TYPE 12

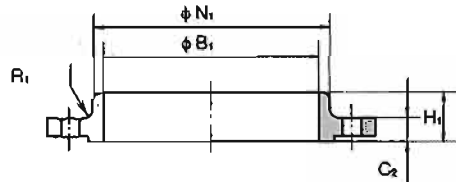

TYPE 13

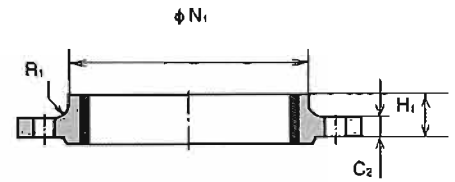

DN	Raised face		Length			Neck diameters		Corner radii	APPROXIMATE WEIGHT				
	d ₁	f ₁	H ₁	H ₂	H ₃	N ₁	N ₂	R ₁					
	Flange type												
	01,05,11,12,13	12 13	11	11	11	12 13	11 12,13		Type01	Type02	Type05	Type11	Type12
10	40	2	22	35	6	28	30	4	0.604	0.591	0.722	0.678	0.646
15	45	2	22	38	6	32	35	4	0.670	0.654	0.813	0.768	0.722
20	58	2	26	40	6	40	45	4	0.936	0.909	1.14	1.09	1.04
25	68	2	28	40	6	46	52	4	1.11	1.08	1.38	1.3	1.25
32	78	2	30	42	6	56	60	6	1.82	1.77	2.03	1.91	1.81
40	88	3	32	45	7	64	70	6	2.08	2.02	2.35	2.15	2.06
50	102	3	28	45	8	74	84	6	2.73	2.52	2.88	2.53	2.39
65	122	3	32	45	10	92	104	6	3.16	3.05	3.51	3.03	2.97
80	138	3	34	50	10	105	118	6	3.79	3.48	4.61	3.92	3.78
100	158	3	40	52	12	131	140	8	4.39	4.20	5.65	4.62	4.38
125	188	3	44	55	12	156	168	8	5.41	5.21	8.13	6.30	6.07
150	212	3	44	55	12	184	195	10	7.14	6.89	10.5	7.81	7.24
200	268	3	44	62	16	235	246	10	9.73	9.31	16.2	11.5	9.8
250	320	3	46	70	16	292	298	12	14.2	13.5	25.0	16.70	13.6
300	378	4	46	78	16	344	350	12	19	18.0	35.1	22.1	17.2
350	438	4	57	82	16	390	400	12	28.2	27.0	48.0	32.8	27.9
400	490	4	63	85	16	445	456	12	35.9	34.6	63.5	41.1	35.7
450	550	4	68	83	16	490	502	12	46.1	44.6	96.8	50.6	45.0
500	610	4	73	84	16	548	559	12	64.0	62.0	133	66.2	60.4
600	725	5	83	88	18	670	658	12	102	98.8	226	104	94
700	795	5	83	104	18	755	760	12	-	107	285	96.5	-
800	900	5	90	108	20	855	864	12	-	152	388	122	-
900	1000	5	94	118	20	955	968	12	-	184	483	155	-
1000	1115	5	100	137	22	1058	1072	16	-	257	640	233	-
1200	1330	5	-	160	30	1262	-	16	-	-	-	390	-
1400	1530	5	-	177	30	1465	-	16	-	-	-	495	-
1600	1750	5	-	204	35	1668	-	16	-	-	-	760	-
1800	1950	5	-	218	35	1870	-	16	-	-	-	929	-
2000	2150	5	-	238	40	2072	-	16	-	-	-	1185	-



EN 1092-1:2007

DIMENSIONS OF PN25 FLANGES

TYPE 01

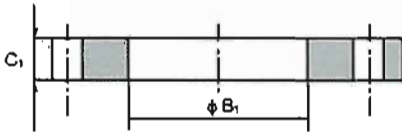

TYPE 02

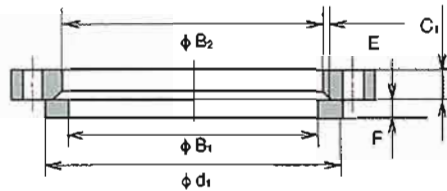

TYPE 05

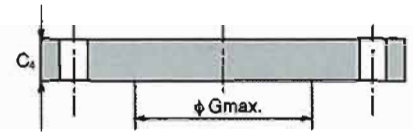

DN	Outside diameter	Diameter of bolt circle	Diameter of bolt hole	Bolt number	Outside diameter of neck A	Bore diameters		Flange thickness			Chamfer E	Wall thickness S	Collar Thickness F	Diameter of shoulder Gmax
						B ₁	B ₂	C ₁	C ₂	C ₄				
						Flange type								
	01,02,05,11,12,13				11	01 12	02	01 02	11 12,13	05	02	11	32	05
10	90	80	14	4	17.2	18.0	21	14	16	16	3	2.0	12	-
15	95	85	14	4	21.3	22.0	25	14	16	16	3	2.0	12	-
20	105	95	14	4	26.9	27.5	31	16	18	18	4	2.3	14	-
25	115	105	14	4	33.7	34.5	38	16	18	18	4	2.6	14	-
32	140	130	18	4	42.4	43.5	47	18	18	18	5	2.6	14	-
40	150	140	18	4	48.3	49.5	53	18	18	18	5	2.6	14	-
50	165	155	18	4	60.3	61.5	65	20	20	20	5	2.9	16	-
65	185	175	18	8	76.1	77.5	81	22	22	22	6	2.9	16	55
80	200	190	18	8	88.9	90.5	94	24	24	24	6	3.2	18	70
100	235	225	22	8	114.3	116.0	120	28	24	24	6	3.6	20	90
125	270	260	26	8	139.7	141.5	145	28	26	26	6	4.0	22	115
150	300	290	26	8	168.3	170.5	174	30	28	28	6	4.5	24	140
200	360	350	26	12	219.1	221.5	226	32	30	30	6	6.3	26	190
250	425	415	30	12	273.0	276.5	281	35	32	32	8	7.1	26	235
300	485	475	30	16	323.9	327.5	333	38	34	34	8	8.0	28	285
350	555	545	33	16	355.6	359.5	365	42	38	38	8	8.0	32	332
400	620	610	36	16	406.4	411.0	416	48	40	40	8	8.8	34	380
450	670	660	36	20	457.0	462.0	467	54	46	50	8	8.8	36	425
500	730	720	36	20	508.0	513.5	519	58	48	51	8	10.0	38	475
600	845	835	39	20	610.0	616.5	622	68	48	66	8	12.5	40	575
700	960	950	42	24	711	-	721	85	50	-	8	14.2	-	-
800	1085	1075	48	24	813	-	824	95	53	-	8	16	-	-
900	1185	1175	48	28	914	-	-	-	57	-	-	17.5	-	-
1000	1320	1310	56	28	1016	-	-	-	63	-	-	20	-	-

EN 1092-1:2007

DIMENSIONS OF PN25 FLANGES

TYPE 11

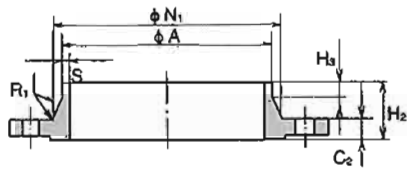

TYPE 12

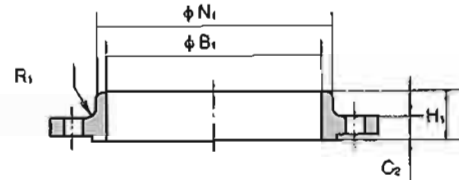

TYPE 13

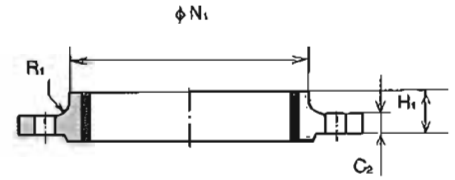

DN	Raised face		Length			Neck diameters		Corner radii	APPROXIMATE WEIGHT				
	d_1	f_1	H_1	H_2	H_3	N_1	N_2	R_1	Flange type				
	01,05,11,12,13		12 13	11	11	11	12 13	11 12,13	Type01	Type02	Type05	Type11	Type12
10	40	2	22	35	6	28	30	4	0.604	0.591	0.722	0.678	0.646
15	45	2	22	38	6	32	35	4	0.670	0.654	0.813	0.768	0.722
20	58	2	26	40	6	40	45	4	0.936	0.909	1.14	1.09	1.04
25	68	2	28	40	6	46	52	4	1.11	1.08	1.38	1.3	1.25
32	78	2	30	42	6	56	60	6	1.82	1.77	2.03	1.91	1.81
40	88	3	32	45	7	64	70	6	2.08	2.02	2.35	2.15	2.06
50	102	3	34	48	8	75	84	6	2.73	2.65	3.20	2.85	2.74
65	122	3	38	52	10	90	104	8	3.48	3.36	4.29	3.68	3.65
80	138	3	40	58	12	105	118	8	4.32	4.18	5.54	4.78	4.59
100	162	3	44	65	12	134	145	8	6.07	5.87	7.60	6.46	6.1
125	188	3	48	68	12	162	170	8	8.19	7.95	10.8	8.86	8.22
150	218	3	52	75	12	192	200	10	10.3	9.97	14.6	11.7	10.6
200	278	3	52	80	16	244	256	10	14.3	13.8	22.5	17.1	14.9
250	335	3	60	88	18	298	310	12	20.1	19.4	33.5	24.3	20.9
300	395	4	67	92	18	352	364	12	26.6	25.5	46.3	31.8	27.3
350	450	4	72	100	20	398	418	12	41.8	40.5	68.1	48.8	45.1
400	505	4	78	110	20	452	472	12	57.6	56.1	89.7	63.3	57.7
450	555	4	84	110	20	500	520	12	69.8	67.8	130	76	69.6
500	615	4	90	125	20	558	580	12	87.0	84.6	159	97	87
600	720	5	100	125	20	660	684	12	127	124	278	121	111
700	820	5	-	129	20	760	-	12	-	-	-	155	-
800	930	5	-	138	22	864	-	12	-	-	-	205	-
900	1030	5	-	148	24	968	-	12	-	-	-	249	-
1000	1140	5	-	160	24	1070	-	16	-	-	-	338	-



EN 1092-1:2007

DIMENSIONS OF PN40 FLANGES

TYPE 01

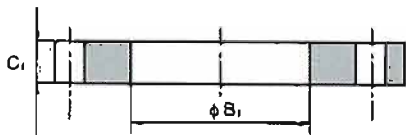

TYPE 02

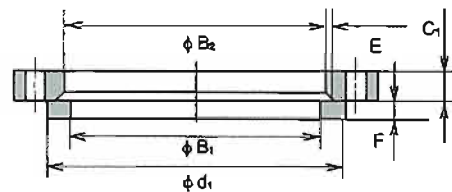

TYPE 05

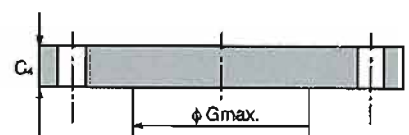

DN	Outside diameter	Diameter of bolt circle	Diameter of bolt hole	Bolt number	Outside diameter of neck A	Bore diameters		Flange thickness			Chamfer E	Wall thickness S	Collar Thickness F	Diameter of shoulder Gmax
						B ₁	B ₂	C ₁	C ₂	C ₄				
						Flange type								
01,02,05,11,12,13					11	01 12	02	01 02	11 12,13	05	02	11	32	05
10	90	60	14	4	17.2	18.0	21	14	16	16	3	2.0	12	-
15	95	65	14	4	21.3	22.0	25	14	16	16	3	2.0	12	-
20	105	75	14	4	26.9	27.5	31	16	18	18	4	2.3	14	-
25	115	85	14	4	33.7	34.5	38	16	18	18	4	2.6	14	-
32	140	100	18	4	42.4	43.5	47	18	18	18	5	2.6	14	-
40	150	110	18	4	48.3	49.5	53	18	18	18	5	2.6	14	-
50	165	125	18	4	60.3	61.5	65	20	20	20	5	2.9	16	-
65	185	145	18	8	76.1	77.5	81	22	22	22	6	2.9	16	55
80	200	160	18	8	88.9	90.5	94	24	24	24	6	3.2	18	70
100	235	190	22	8	114.3	116.0	120	26	24	24	6	3.6	20	90
125	270	220	26	8	139.7	141.5	145	28	26	26	6	4.0	22	115
150	300	250	26	8	168.3	170.5	174	30	28	28	6	4.5	24	140
200	375	320	30	12	219.1	221.5	226	36	34	36	6	6.3	28	190
250	450	385	33	12	273.0	276.5	281	42	38	38	8	7.1	30	235
300	515	450	33	16	323.9	327.5	333	52	42	42	8	8.0	34	285
350	580	510	36	16	355.6	359.5	365	58	46	46	8	8.8	36	330
400	660	585	39	16	406.4	411.0	416	65	50	50	8	11.0	42	380
450	685	610	39	20	457.0	462.0	467	To be specified by the purchaser	57	57	8	12.5	46	425
500	755	670	42	20	508.0	513.5	519		57	57	8	14.2	50	475
600	890	795	48	20	610.0	616.5	622		72	72	8	16.0	54	575

EN 1092-1:2007

DIMENSIONS OF PN40 FLANGES

TYPE 11

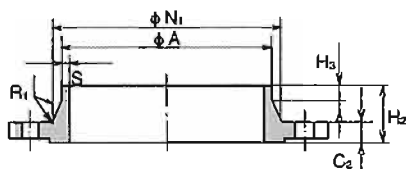

TYPE 12

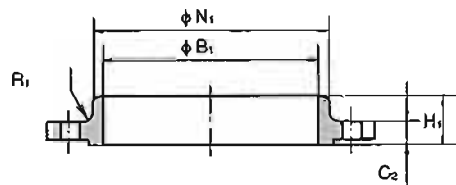

TYPE 13

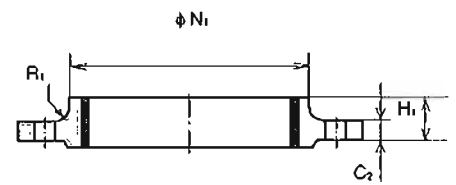

DN	Raised face		Length			Neck diameters		Corner radii	APPROXIMATE WEIGHT				
	d_1	f_1	H_1	H_2	H_3	N_1	N_2	R_1					
	Flange type									Type01	Type02	Type05	Type11
	01,05,11,12,13	12,13	11	11	11	12,13	11,12,13						
10	40	2	22	35	6	28	30	4	0.604	0.591	0.722	0.678	0.646
15	45	2	22	38	6	32	35	4	0.67	0.654	0.813	0.768	0.722
20	58	2	26	40	6	40	45	4	0.936	0.909	1.14	1.09	1.04
25	68	2	28	40	6	46	52	4	1.11	1.08	1.38	1.30	1.25
32	78	2	30	42	6	56	60	6	1.82	1.77	2.03	1.91	1.81
40	88	3	32	45	7	64	70	6	2.08	2.02	2.35	2.15	2.06
50	102	3	34	48	8	75	84	6	2.73	2.65	3.20	2.85	2.74
65	122	3	38	52	10	90	104	6	3.48	3.36	4.29	3.68	3.65
80	138	3	40	58	12	105	118	8	4.32	4.18	5.54	4.78	4.59
100	162	3	44	65	12	134	145	8	6.07	5.87	7.60	6.46	6.10
125	188	3	48	68	12	162	170	8	8.19	7.95	10.8	8.86	8.22
150	218	3	52	75	12	192	200	10	10.3	9.97	14.6	11.7	10.6
200	285	3	52	88	16	244	260	10	17.9	17.4	28.8	21.0	18.3
250	345	3	60	105	18	306	312	12	29.3	28.4	44.4	34.2	28.3
300	410	4	67	115	18	362	380	12	45.1	43.6	64.2	47.6	40.4
350	465	4	72	125	20	408	424	12	66.7	64.9	89.5	69.3	58.8
400	535	4	78	135	20	462	478	12	97.1	95.1	127	98	82.1
450	560	4	84	135	20	500	522	12	-	-	154	105	86.2
500	615	4	90	140	20	562	576	12	-	-	188	130	105
600	735	5	100	150	20	666	686	12	-	-	331	209	172



河北海浩

GOST 12820-80 PN6.....	82	GOST 12821-80 PN16.....	88
GOST 12820-80 PN10.....	83	GOST 12821-80 PN25.....	89
GOST 12820-80 PN16.....	84	GOST 12821-80 PN40.....	90
GOST 12820-80 PN25.....	85	GOST 12821-80 PN63.....	91
GOST 12821-80 PN6.....	86	GOST 12821-80 PN100.....	92
GOST 12821-80 PN10.....	87	GOST 12821-80 PN160.....	93



俄标
法兰参数系列

GOST 12820-80 PN6 STEEL PLAIN WELDED FLANGES

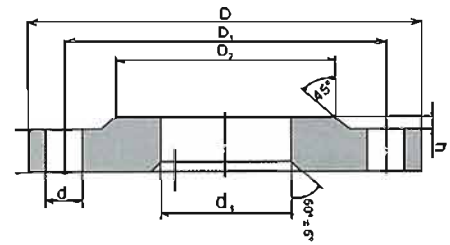

UNIT:mm

Nomenclature	Dimensions,mm								Weight,kg
	D	D ₁	D ₂	d ₁	b	h	n	d	
$P_{nom}=0.6\text{Mpa}(6\text{kgf/cm}^2)$									
1-10-6	75	50	35	15	10	2	4	11	0.31
1-15-6	80	55	40	19	10	2	4	11	0.33
1-20-6	90	65	50	26	12	2	4	11	0.53
1-25-6	100	75	60	33	12	2	4	11	0.64
1-32-6	120	90	70	39	13	2	4	14	1.01
1-40-6	130	100	80	46	13	3	4	14	1.21
1-50-6	140	110	90	59	13	3	4	14	1.33
1-65-6	160	130	110	78	13	3	4	14	1.63
1-80-6	185	150	128	91	15	3	4	18	2.44
1-100-6	205	170	148	110	15	3	4	18	2.85
1-125-6	235	200	178	135	17	3	8	18	3.88
1-150-6	260	225	202	161	17	3	8	18	4.39
1-175-6	290	255	232	196	19	3	8	18	5.36
1-200-6	315	280	258	222	19	3	8	18	5.89
1-225-6	340	305	282	245	19	3	8	18	6.60
1-250-6	370	335	312	273	20	3	12	18	7.67
1-300-6	435	395	365	325	20	4	12	22	10.28
1-350-6	485	445	415	377	22	4	12	22	12.58
1-400-6	535	495	465	426	24	4	16	22	15.20
1-450-6	590	550	520	480	24	4	16	22	17.25
1-500-6	640	600	570	530	25	4	16	22	19.72
1-600-6	755	705	670	630	25	5	20	26	26.24
1-700-6	860	810	775	720	27	5	24	26	36.68
1-800-6	975	920	880	820	27	5	24	30	46.14
1-900-6	1075	1020	980	920	29	5	24	30	55.10
1-1000-6	1175	1120	1080	1020	31	5	28	30	64.36
1-1200-6	1400	1340	1295	1220	34	5	32	33	99.03



GOST 12820-80 PN10

STEEL PLAIN WELDED FLANGES

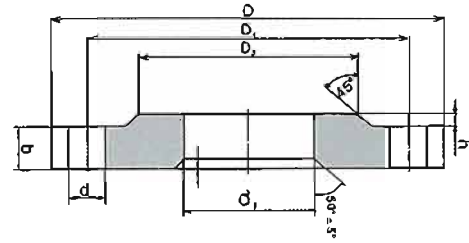

UNIT:mm

Nomenclature	Dimensions,mm								Weight,kg
	D	D ₁	D ₂	d ₁	b	h	n	d	
P _{nom} =1.0Mpa(10kgf/cm ²)									
1-10-10	90	60	42	15	10	2	4	14	0.46
1-15-10	95	65	47	19	10	2	4	14	0.51
1-20-10	105	75	58	26	12	2	4	14	0.74
1-25-10	115	85	68	33	12	2	4	14	0.89
1-32-10	135	100	78	39	14	2	4	18	1.40
1-40-10	145	110	88	46	15	3	4	18	1.71
1-50-10	160	125	102	59	15	3	4	18	2.06
1-65-10	180	145	122	78	17	3	4	18	2.80
1-80-10	195	160	133	91	17	3	4	18	3.19
1-100-10	215	180	158	110	19	3	8	18	3.96
1-125-10	245	210	184	135	21	3	8	18	5.40
1-150-10	280	240	212	161	21	3	8	22	6.62
1-175-10	310	270	242	196	21	3	8	22	7.32
1-200-10	335	295	268	222	21	3	8	22	8.05
1-225-10	365	325	295	245	21	3	8	22	9.30
1-250-10	390	350	320	273	23	3	12	22	10.65
1-300-10	440	400	370	325	24	4	12	22	12.90
1-350-10	500	460	430	377	24	4	16	22	15.85
1-400-10	565	515	482	426	26	4	16	26	21.56
1-450-10	615	565	532	480	26	4	20	26	22.76
1-500-10	670	620	585	530	28	4	20	26	27.70
1-600-10	780	725	685	630	31	5	20	30	39.40
1-700-10	895	840	800	720	34	5	24	30	59.46
1-800-10	1010	950	905	820	37	5	24	33	79.16
1-900-10	1110	1050	1005	920	40	5	28	33	94.13
1-1000-10	1220	1160	1110	1020	43	5	28	33	118.43
1-1200-10	1455	1380	1330	1222	51	5	32	39	197.44

GOST 12820-80 PN16

STEEL PLAIN WELDED FLANGES

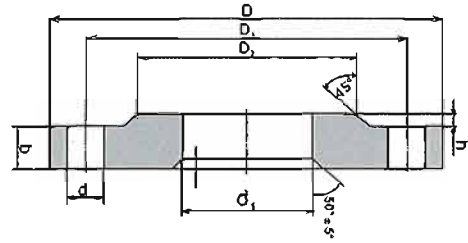

UNIT:mm

Nomenclature	Dimensions,mm								Weight,kg
	D	D ₁	D ₂	d ₁	b	h	n	d	
$P_{nom}=1.6\text{Mpa}(16\text{kgf/cm}^2)$									
1-10-16	90	60	42	15	12	2	4	14	0.54
1-15-16	95	65	47	19	12	2	4	14	0.61
1-20-16	105	75	58	26	14	2	4	14	0.86
1-25-16	115	85	68	33	16	2	4	14	1.17
1-32-16	135	100	78	39	16	2	4	18	1.58
1-40-16	145	110	88	46	17	3	4	18	1.96
1-50-16	160	125	102	59	19	3	4	18	2.58
1-65-16	180	145	122	78	21	3	4	18	3.42
1-80-16	195	160	133	91	21	3	4	18	3.71
1-100-16	215	180	158	110	23	3	8	18	4.73
1-125-16	245	210	184	135	25	3	8	18	6.38
1-150-16	280	240	212	161	25	3	8	22	7.81
1-175-16	310	270	242	196	25	3	8	22	8.64
1-200-16	335	295	268	222	27	3	12	22	10.10
1-225-16	365	325	295	245	27	3	12	22	11.70
1-250-16	405	355	320	273	28	3	12	26	14.49
1-300-16	460	410	370	325	28	4	12	26	17.78
1-350-16	520	470	430	377	30	4	16	26	22.88
1-400-16	580	525	482	426	34	4	16	30	31.00
1-450-16	640	585	532	480	38	4	20	30	39.64
1-500-16	710	650	585	530	44	4	20	33	57.01
1-600-16	840	770	685	630	45	5	20	39	80.03
1-700-16	910	840	800	720	47	5	24	39	84.21
1-800-16	1020	950	905	820	49	5	24	39	104.41
1-900-16	1120	1050	1005	920	54	5	28	39	128.60
1-1000-16	1255	1170	1110	1020	58	5	28	45	179.37
1-1200-16	1485	1390	1330	1220	71	5	32	52	297.78



GOST 12820-80 PN25

STEEL PLAIN WELDED FLANGES

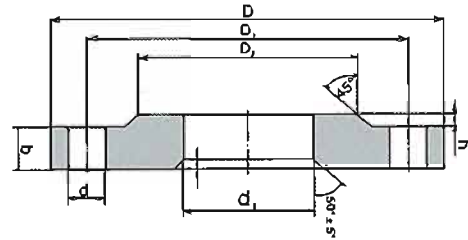

UNIT:mm

Nomenclature	Dimensions,mm								Weight,kg
	D	D ₁	D ₂	d ₁	b	h	n	d	
$P_{nom}=2.5\text{Mpa}(25\text{kgf/cm}^2)$									
1-10-25	90	60	42	15	14	2	4	14	0.63
1-15-25	95	65	47	19	14	2	4	14	0.70
1-20-25	105	75	58	26	16	2	4	14	0.98
1-25-25	115	85	68	33	16	2	4	14	1.17
1-32-25	135	100	78	39	18	2	4	18	1.77
1-40-25	145	110	88	46	19	3	4	18	2.18
1-50-25	160	125	102	59	21	3	4	18	2.71
1-65-25	180	145	122	78	21	3	8	18	3.22
1-80-25	195	160	133	91	23	3	8	18	4.06
1-100-25	230	190	158	110	25	3	8	22	5.92
1-125-25	270	220	184	135	27	3	8	26	8.26
1-150-25	300	250	212	161	27	3	8	26	10.12
1-200-25	360	310	278	222	29	3	12	26	13.34
1-250-25	425	370	335	273	31	3	12	30	18.90
1-300-25	485	430	390	325	32	4	16	30	23.95
1-350-25	550	490	450	377	38	4	16	33	34.35
1-400-25	610	550	505	426	40	4	16	33	44.62
1-500-25	730	660	615	530	48	4	20	39	67.30
1-600-25	840	770	720	630	49	5	20	39	90.87
1-800-25	1075	990	930	820	63	5	24	45	181.43

GOST 12821-80 PN6 STEEL PLAIN WELDED FLANGES

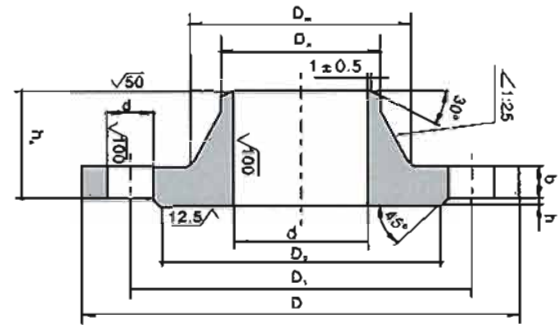

Nomenclature	Dimensions, mm											Weight, Kg
	D	D ₁	D ₂	h	d ₁	b	h _a	D _m	D _n	n, Number of holes	d	
$P_{nom} = 0,6 \text{ MPa (6 kgf/cm}^2\text{)}$												
1-10-6	75	50	35	2	8	10	27	22	15	4	11	0.34
1-15-6	80	55	40	2	12	10	28	28	19	4	11	0.40
1-20-6	90	65	50	2	18	10	30	36	26	4	11	0.53
1-25-6	100	75	60	2	25	12	30	42	33	4	11	0.76
1-32-6	120	90	70	2	31	12	33	50	39	4	14	1.10
1-40-6	130	100	80	3	38	12	35	60	46	4	14	1.36
1-50-6	140	110	90	3	49	12	35	70	58	4	14	1.53
1-65-6	160	130	110	3	66	12	35	88	77	4	14	1.97
1-80-6	185	150	128	3	78	13	37	102	90	4	18	2.76
1-100-6	205	170	148	3	96	13	38	122	110	4	18	3.35
1-125-6	235	200	178	3	121	15	40	148	135	8	18	4.66
1-150-6	260	225	202	3	146	15	43	172	161	8	18	5.37
1-175-6	290	255	232	3	177	17	47	210	196	8	18	7.32
1-200-6	315	280	258	3	202	17	50	235	222	8	18	8.37
1-225-6	340	305	282	3	226	17	50	260	248	8	18	9.45
1-250-6	370	335	312	3	254	18	50	288	278	12	18	10.99
1-300-6	435	395	365	4	303	18	50	340	330	12	22	14.82
1-350-6	485	445	415	4	351	18	50	390	382	12	22	17.69
1-400-6	535	495	465	4	398	18	50	440	432	16	22	20.55
1-450-6	590	550	520	4	450	18	50	494	484	16	22	23.63
1-500-6	640	600	570	4	501	19	50	545	535	16	22	26.63
1-600-6	755	705	670	5	602	19	55	650	636	20	26	35.79
1-700-6	860	810	775	5	692	19	55	740	726	24	26	44.31
1-800-6	975	920	880	5	792	19	60	844	826	24	30	56.17
1-900-6	1075	1020	980	5	892	21	60	944	926	24	30	66.79
1-1000-6	1175	1120	1080	5	992	21	60	1044	1028	28	30	73.51
1-1200-6	1400	1340	1295	5	1192	23	70	1248	1228	32	33	111.43



GOST 12821-80 PN10

STEEL PLAIN WELDED FLANGES

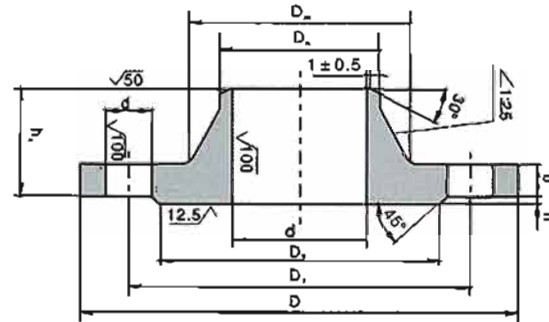

Nomenclature	Dimensions, mm											Weight, Kg
	D	D ₁	D ₂	h	d ₁	b	h ₄	D _m	D _n	n, Number of holes	d	
$P_{nom} = 1,0 \text{ MPa (10 kgf/cm}^2\text{)}$												
1-10-10	90	60	42	2	8	10	33	25	15	4	14	0.50
1-15-10	95	65	47	2	12	10	33	30	19	4	14	0.58
1-20-10	105	75	58	2	18	12	36	38	26	4	14	0.87
1-25-10	115	85	68	2	25	12	38	45	33	4	14	1.05
1-32-10	135	100	78	2	31	13	40	55	39	4	18	1.54
1-40-10	145	110	88	3	38	13	42	62	46	4	18	1.83
1-50-10	160	125	102	3	49	13	42	76	58	4	18	2.26
1-65-10	180	145	122	3	66	15	45	94	77	4	18	3.17
1-80-10	195	160	133	3	78	15	47	105	90	4	18	3.67
1-100-10	215	180	158	3	96	17	48	128	110	8	18	4.70
1-125-10	245	210	184	3	121	19	57	156	135	8	18	6.71
1-150-10	280	240	212	3	146	19	57	180	161	8	22	8.17
1-175-10	310	270	242	3	177	19	57	210	196	8	22	9.71
1-200-10	335	295	268	3	202	19	58	240	222	8	22	11.35
1-225-10	365	325	295	3	226	19	60	268	248	8	22	13.24
1-250-10	390	350	320	3	254	21	60	290	278	12	22	14.64
1-300-10	440	400	370	4	303	22	60	345	330	12	22	18.66
1-350-10	500	460	430	4	351	22	60	400	382	16	22	24.00
1-400-10	565	515	482	4	398	22	60	445	432	16	26	30.00
1-450-10	615	565	532	4	450	22	65	500	484	20	26	33.33
1-500-10	670	620	585	4	501	24	65	550	535	20	26	39.20
1-600-10	780	725	685	5	602	24	65	650	636	20	30	48.80
1-700-10	895	840	800	5	692	25	65	744	726	24	30	65.26
1-800-10	1010	950	905	5	792	27	75	850	826	24	33	87.24
1-900-10	1110	1050	1005	5	892	29	80	950	926	28	33	103.02
1-1000-10	1220	1160	1110	5	992	29	80	1050	1028	28	33	119.19
1-1200-10	1455	1380	1330	5	1192	33	90	1256	1228	32	39	179.91

GOST 12821-80 PN16

STEEL PLAIN WELDED FLANGES

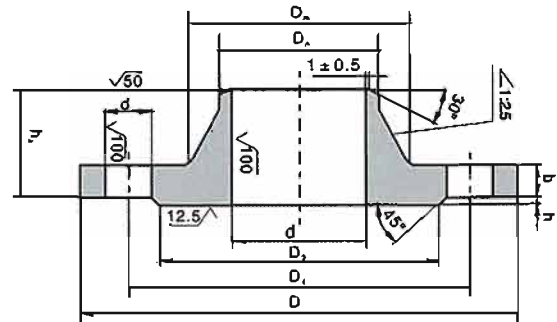

Nomenclature	Dimensions, mm											Weight, Kg
	D	D ₁	D ₂	h	d ₁	b	h ₁	D _m	D _a	n, Number of holes	d	
$P_{nom} = 1,6 \text{ MPa (16 kgf/cm}^2\text{)}$												
1-10-16	90	60	42	2	8	12	33	26	15	4	14	0.59
1-15-16	95	65	47	2	12	12	33	30	19	4	14	0.68
1-20-16	105	75	58	2	18	12	36	28	26	4	14	0.87
1-25-16	115	85	68	2	25	12	38	45	33	4	14	1.05
1-32-16	135	100	78	2	31	13	40	55	39	4	18	1.54
1-40-16	145	110	88	3	38	13	42	64	46	4	18	1.85
1-50-16	160	125	102	3	49	13	45	78	58	4	18	2.28
1-65-16	180	145	122	3	66	15	47	94	77	4	18	3.19
1-80-16	195	160	133	3	78	17	50	110	90	4	18	4.21
1-100-16	215	180	158	3	96	17	50	130	110	8	18	4.90
1-125-16	245	210	184	3	121	19	57	156	135	8	18	6.75
1-150-16	280	240	212	3	146	19	57	180	161	8	22	8.3
1-175-16	310	270	242	3	177	21	57	210	196	8	22	10.37
1-200-16	335	295	268	3	202	21	58	240	222	12	22	11.79
1-225-16	365	325	295	3	226	21	65	268	248	12	22	14.12
1-250-16	405	355	320	3	254	23	65	292	278	12	26	17.36
1-300-16	480	410	370	4	303	24	66	346	330	12	26	22.76
1-350-16	520	470	430	4	351	28	70	400	382	16	26	32.04
1-400-16	580	525	482	4	398	32	75	450	432	16	30	43.00
1-450-16	640	585	532	4	450	34	85	506	484	20	30	54.00
1-500-16	710	650	585	4	501	38	90	559	535	20	33	70.97
1-600-16	840	770	685	5	602	41	90	660	636	20	39	99.30
1-700-16	910	840	800	5	692	43	95	750	726	24	39	105.90
1-800-16	1020	950	905	5	792	45	95	850	826	24	39	130.57
1-900-16	1120	1050	1005	5	892	47	110	958	926	28	39	157.83
1-1000-16	1255	1170	1110	5	992	49	110	1060	1028	28	45	203.39
1-1200-16	1485	1390	1330	5	1192	51	125	1268	1228	32	52	284.94



GOST 12821-80 PN25

STEEL PLAIN WELDED FLANGES

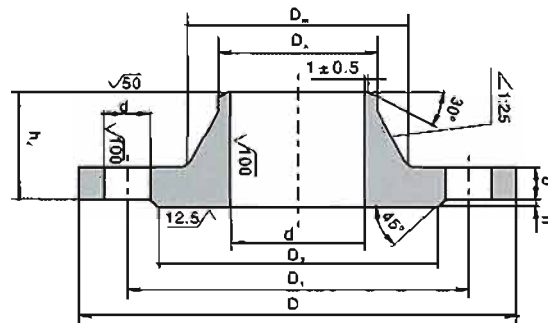

Nomenclature	Dimensions, mm											Weight, Kg
	D	D ₁	D ₂	h	d ₁	b	h ₁	D _m	D _n	n, Number of holes	d	
$P_{nom} = 2,5 \text{ MPa (25 kgf/cm}^2\text{)}$												
1-10-25	90	60	42	2	8	14	33	28	15	4	14	0.68
1-15-25	95	65	47	2	12	14	33	30	19	4	14	0.79
1-20-25	105	75	58	2	18	14	34	38	26	4	14	0.97
1-25-25	145	85	68	2	25	14	36	45	33	4	14	1.18
1-32-25	135	100	78	2	31	16	43	56	39	4	18	1.83
1-40-25	115	110	88	3	38	16	45	64	46	4	18	2.19
1-50-25	160	125	102	3	49	17	45	76	58	4	18	2.78
1-65-25	180	145	122	3	66	19	50	96	77	8	18	3.71
1-80-25	195	160	133	3	78	19	52	110	90	8	18	4.44
1-100-25	230	190	158	3	96	21	58	132	110	8	22	6.51
1-125-25	270	220	184	3	121	23	65	160	135	8	26	9.41
1-150-25	300	250	212	3	146	25	68	186	161	8	26	12.52
1-175-25	330	280	242	3	177	25	70	216	196	12	26	13.88
1-200-25	360	310	278	3	202	27	75	245	222	12	26	17.44
1-225-25	395	340	305	3	228	29	75	270	248	12	30	21.56
1-250-25	425	370	335	3	254	29	75	300	278	12	30	24.40
1-300-25	485	430	390	4	303	32	80	352	330	16	30	33.29
1-350-25	550	490	450	4	351	36	85	406	382	16	33	46.57
1-400-25	610	550	505	4	398	40	100	464	432	16	33	64.81
1-450-25	660	600	555	4	450	42	100	515	484	20	33	72.26
1-500-25	730	680	615	4	500	44	100	570	535	20	39	88.91
1-600-25	840	770	720	5	600	49	115	670	636	20	39	123.70
1-700-25	960	875	820	5	690	53	125	766	726	24	45	186.81
1-800-25	1075	990	930	5	790	55	135	874	826	24	45	213.9
1-900-25	1185	1090	1030	5	892	57	145	980	926	28	52	213.90
1-1000-25	1315	1210	1140	5	992	59	150	1084	1028	28	56	312.12
1-1200-25	1525	1420	1350	5	1192	62	160	1288	1228	32	56	387.50

GOST 12821-80 PN40

STEEL PLAIN WELDED FLANGES

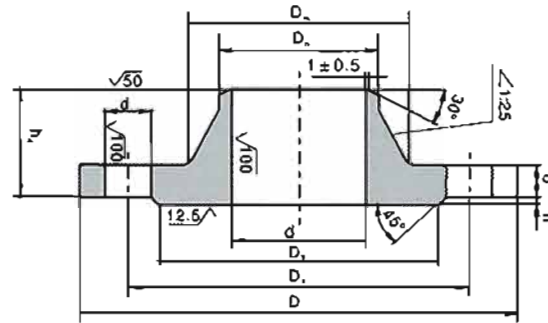

Nomenclature	Dimensions, mm											Weight kg
	D	D ₁	D ₂	h	d ₁	b	h ₁	D _m	D _n	n, Number of holes	d	
$P_{nom} = 4.0 \text{ MPa (40 kgf/cm}^2\text{)}$												
1-10-40	90	60	42	2	8	14	33	26	15	4	14	0.68
1-15-40	95	65	47	2	12	14	33	30	19	4	14	0.79
1-20-40	105	75	58	2	18	14	34	38	26	4	14	0.97
1-25-40	115	85	68	2	25	14	36	45	33	4	14	1.18
1-32-40	135	100	78	2	31	16	43	56	39	4	18	1.83
1-40-40	145	110	88	3	38	16	45	64	46	4	18	2.19
1-50-40	160	125	102	3	48	17	45	76	58	4	18	2.81
1-65-40	180	145	122	3	66	19	50	96	77	8	18	3.71
1-80-40	195	160	133	3	78	21	55	112	90	8	18	4.8
1-100-40	230	190	158	3	98	23	65	138	110	8	22	7.4
1-125-40	270	220	184	3	120	25	65	160	135	8	26	10.00
1-150-40	300	250	212	3	145	27	68	186	161	8	26	13.03
1-175-40	350	295	242	3	177	33	85	226	196	12	30	20.75
1-200-40	375	320	285	3	200	35	85	250	222	12	30	24.44
1-225-40	415	355	315	3	226	37	95	280	248	12	33	31.33
1-250-40	445	385	345	3	252	39	98	310	278	12	33	37.59
1-300-40	510	450	410	4	301	42	112	368	330	16	33	57.10
1-350-40	570	510	465	4	351	48	116	418	382	16	33	70.34
1-400-40	655	585	535	4	398	54	135	480	432	16	39	106.76
1-450-40	680	610	560	4	448	56	135	530	484	20	39	107.00
1-500-40	755	670	615	4	495	58	140	580	535	20	45	132.33
1-600-40	890	795	735	5	595	58	140	686	636	20	52	180.95
1-700-40	995	900	810	5	695	63	160	790	726	24	52	228.25
1-800-40	1135	1030	960	5	795	71	190	908	826	24	56	343.69
1-900-40	1250	1140	1070	5	895	74	215	1024	926	28	56	436.54
1-1000-40	1360	1250	1180	5	995	77	235	1140	1028	28	56	540.75
1-1200-40	1575	1460	1380	5	1195	80	250	1350	1228	32	62	690.59



GOST 12821-80 PN63

STEEL PLAIN WELDED FLANGES

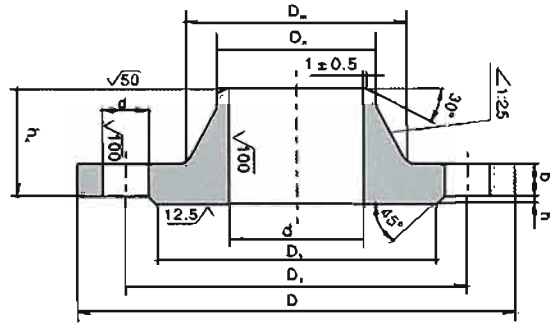

Nomenclature	Dimensions, mm											Weight kg
	D	D ₁	D ₂	h	d ₁	b	h ₄	D _m	D _n	n, Number of holes	d	
$P_{nom} = 6.3 \text{MPa} (63 \text{kgf/cm}^2)$												
1-10-63	100	70	42	2	8	16	46	34	15	4	14	1.03
1-15-63	105	75	47	2	12	16	46	38	19	4	14	1.15
1-20-63	125	90	58	2	18	18	54	48	26	4	18	1.80
1-25-63	135	100	68	2	25	20	56	52	33	4	18	2.30
1-32-63	150	110	78	2	31	21	60	64	39	4	22	2.94
1-40-63	165	125	88	3	37	21	65	74	48	4	22	3.75
1-50-63	175	135	102	3	47	23	67	86	58	4	22	4.63
1-65-63	200	160	122	3	64	25	72	106	77	8	22	6.29
1-80-63	210	170	133	3	77	27	72	120	90	8	22	7.22
1-100-63	250	200	158	3	94	29	77	140	110	8	26	10.71
1-125-63	295	240	184	3	118	33	95	172	135	8	30	17.13
1-150-63	340	280	212	3	142	35	105	206	161	8	33	24.60
1-175-63	370	310	212	3	174	39	105	232	196	12	33	28.61
1-200-63	405	345	285	3	198	41	110	264	222	12	33	36.60
1-225-63	430	370	315	3	222	43	115	290	248	12	33	42.54
1-250-63	470	400	345	3	246	45	115	316	278	12	39	50.89
1-300-63	530	460	410	4	294	50	120	370	330	16	39	68.15
1-350-63	595	525	465	4	342	56	140	430	382	16	39	98.68
1-400-63	670	585	535	4	386	62	155	484	432	16	45	135.80
1-500-63	800	705	615	4	485	66	165	594	535	20	52	192.74
1-600-63	925	820	735	5	585	71	180	704	636	20	56	269.27
1-700-63	1045	935	840	5	685	76	225	820	726	24	56	300.86
1-800-63	1165	1050	960	5	785	85	225	920	826	24	62	463.87
1-900-63	1285	1170	1070	5	885	88	265	1050	926	28	62	954.41
1-1000-63	1415	1290	1180	5	985	92	280	1160	1028	28	70	980.60
1-1200-63	1665	1530	1380	5	1185	95	315	1388	1228	32	78	1263.72

GOST 12821-80 PN100

STEEL PLAIN WELDED FLANGES

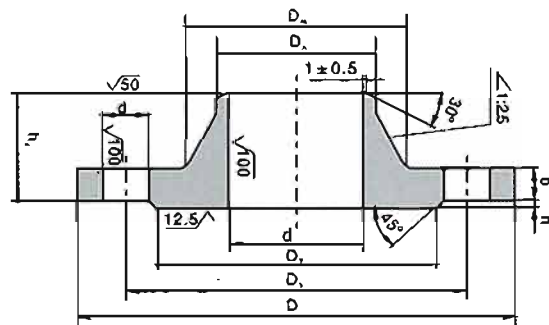

Nomenclature	Dimensions, mm											Weight kg
	D	D ₁	D ₂	h	d ₁	b	h ₄	D _m	D _n	n, Number of holes	d	
$P_{nom} = 10 \text{MPa} (100 \text{kgf/cm}^2)$												
1-10-100	100	70	42	2	8	16	43	34	15	4	14	1.02
1-15-100	105	75	47	2	12	18	46	38	19	4	14	1.26
1-20-100	125	90	58	2	18	20	51	48	26	4	18	1.98
1-25-100	135	100	68	2	25	22	56	52	33	4	18	2.48
1-32-100	150	110	78	2	31	22	60	64	39	4	22	3.05
1-40-100	165	125	88	3	37	23	67	76	46	4	22	4.06
1-50-100	195	145	102	3	45	25	68	86	58	4	26	6.03
1-65-100	220	170	122	3	62	29	80	110	77	8	26	8.52
1-80-100	230	180	133	3	75	31	87	124	90	8	26	9.91
1-100-100	265	210	158	3	92	35	97	146	110	8	30	14.65
1-125-100	310	250	184	3	112	39	112	180	135	8	33	23.32
1-150-100	350	290	212	3	136	43	125	214	161	12	33	32.87
1-175-100	380	320	242	3	166	45	125	246	196	12	33	39.00
1-200-100	430	360	265	3	190	51	140	276	222	12	39	54.24
1-225-100	470	400	315	3	212	53	155	312	248	12	39	71.19
1-250-100	500	430	345	3	236	57	160	340	278	12	39	85.24
1-300-100	585	500	410	4	284	66	180	400	330	16	45	127.78
1-350-100	655	560	465	4	332	72	195	460	382	16	52	170.94
1-400-100	715	620	535	4	376	78	200	510	432	16	52	216.44



GOST 12821-80 PN160

STEEL PLAIN WELDED FLANGES

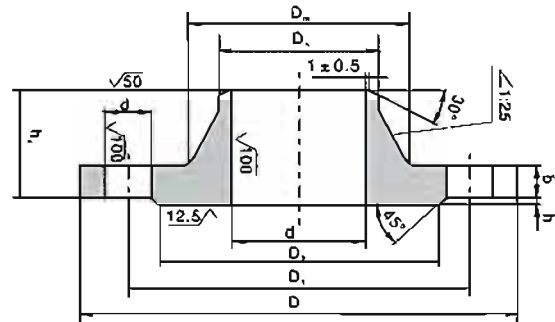

Nomenclature	Dimensions, mm											Weight kg
	D	D ₁	D ₂	h	d ₁	b	h ₄	D _m	D _n	n, Number of holes	d	
$P_{nom}=16\text{MPa} (160\text{kgf/cm}^2)$												
1-15-160	105	75	47	2	12	18	50	38	19	4	14	1.27
1-20-160	125	90	58	2	18	20	56	48	26	4	18	1.98
1-25-160	135	100	68	2	25	22	56	52	33	4	18	2.48
1-32-160	150	110	78	2	31	22	65	64	39	4	22	3.07
1-40-160	165	125	88	3	37	25	72	76	46	4	22	4.01
1-50-160	195	145	102	3	45	27	75	86	58	4	26	6.43
1-65-160	220	170	122	3	62	31	85	110	77	8	26	9.38
1-80-160	230	180	133	3	75	33	90	124	90	8	26	10.40
1-100-160	265	210	158	3	92	37	100	146	110	8	30	15.40
1-125-160	310	250	184	3	112	41	115	180	135	8	33	24.87
1-150-160	350	290	212	3	136	47	130	214	161	12	33	35.04
1-175-160	380	320	242	3	166	51	135	246	196	12	33	43.10
1-200-160	430	360	285	3	190	57	145	276	222	12	39	60.10
1-225-160	470	400	315	3	212	60	160	312	248	12	39	78.80
1-250-160	500	430	345	3	236	65	165	340	278	12	39	94.40
1-300-160	585	500	410	4	284	74	185	400	330	16	45	141.00



河北海浩

SABS 1123-1600/3	95
SABS 1123-1600/4	96
BS 10 TABLE D SCREWED	97
BS 10 TABLE D	98
BS 10 TABLE E	99



南非标 法兰参数系列



SABS 1123-1600/3

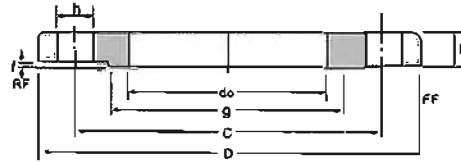

Nominal Pipe Size	Outside Diam	Pipe	BORE	Thickness	Bolt circle diam	Raise Face		Diam of Bolt	Number of holes	Weight / kg	
						g	f			Slip on	Blind
1600/3	D	OD	do	t	C	g	f	H	N	Slip on	Blind
15MM	95	21.3	22	10	65	45	2	14	4	0.48	0.51
20MM	105	26.9	27.6	10	75	58	2	14	4	0.58	0.63
25MM	115	33.7	34.4	10	85	68	2	14	4	0.69	0.77
32MM	140	42.4	43.1	10	100	78	2	18	4	1.01	1.13
40MM	150	48.3	49	10	110	88	3	18	4	1.16	1.31
50MM	165	60.3	61.1	12	125	102	3	18	4	1.64	1.92
65MM	185	76.1	77.1	12	145	122	3	18	4	1.99	2.44
80MM	200	88.9	90.3	14	160	138	3	18	8	2.52	3.23
100MM	220	114.3	115.9	14	180	158	3	18	8	2.8	3.96
125MM	250	139.7	141.6	16	210	188	3	18	8	3.96	5.91
150MM	285	168.3	170.5	18	240	212	3	22	8	5.47	8.59
200MM	340	219.1	221.8	22	295	268	3	22	12	8.29	14.9
250MM	405	273	276.2	25	355	320	3	26	12	12.4	24.05
300MM	460	323.9	327.6	28	410	378	4	26	12	16.82	35.15
350MM	520	355.6	359.7	30	470	438	4	26	16	24.37	48.05
400MM	580	406.4	411	35	525	490	4	26	16	34.42	70.31
450MM	640	457	462.5	40	585	550	4	26	20	45.83	97.75
500MM	715	508	513.6	40	650	610	4	33	20	56.69	120.8
600MM	840	610	616.5	50	770	725	5	33	20	95.19	210.96

SABS 1123-1600/4

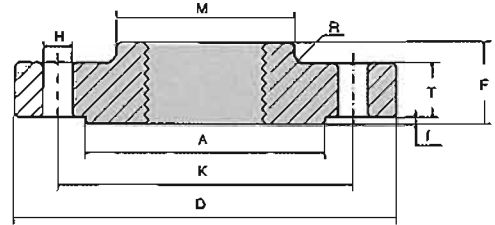

压力	通径	外径	中心距	孔径	孔数	内径	盘厚	总高	突台径	R	台径	台高	RF 单重	FF 单重
PN	DN	D	K	H	—	BSP	T	F	M	R	A	f	KG	KG
Nominal pressure 1600/4kPa	10	90	60	14	4	15.00	8	14	30	4	40	2	0.38	0.45
	15	95	65	14	4	17.00	8	14	35	4	45	2	0.44	0.51
	20	105	75	14	4	22.50	8	16	45	4	58	2	0.57	0.66
	25	115	85	14	4	29.00	8	16	52	4	68	2	0.69	0.78
	32	140	100	18	4	37.50	10	20	60	6	78	2	1.21	1.36
	40	150	110	18	4	43.50	10	20	70	6	88	3	1.43	1.68
	50	165	125	18	4	55.00	12	22	85	6	102	3	2.01	2.30
	65	185	145	18	4	71.00	12	26	105	6	122	3	2.65	2.99
	80	200	160	18	8	83.50	14	28	118	8	138	3	3.32	3.66
	100	220	180	18	8	108.50	14	34	140	8	158	3	4.01	4.39
	*125	250	210	18	8	134.00	16	38	168	8	188	3	5.67	6.12
150	285	240	22	8	159.50	18	40	195	10	212	3	7.60	8.20	



BS 10 TABLE D SCREWED

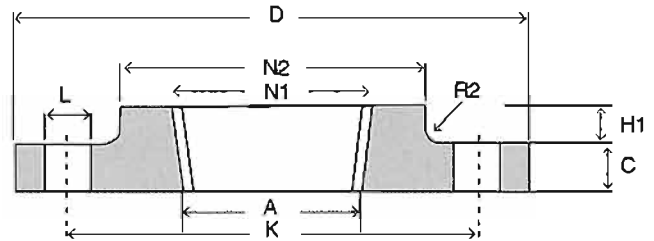

N.B Size		外径	中心距	孔径	内径	板厚	大内径	颈外径	颈高		孔数	单重
		D	K	L	A	C	N1	N2	H1	R2	No. Holes	Unit Weight
Ins	mm	mm	mm	mm	mm	mm	mm	mm	mm			KG
1/2 "	15	95.3	66.8	14.5	18.7	4.8	19.7	33.3	9.5	1.6	4	0.28
3/4 "	20	101.6	73.2	14.5	24.3	4.8	25.3	38.1	11.1	1.6	4	0.32
1 "	25	114.3	82.6	14.5	30.5	4.8	31.7	47.6	11.1	1.6	4	0.43
1 1/4 "	32	120.7	87.4	14.5	39	6.4	40.4	55.6	11.1	1.6	4	0.59
1 1/2 "	40	133.4	98.6	14.5	44.9	6.4	46.3	61.9	12.7	1.6	4	0.73
2 "	50	152.4	114.3	17.5	56.7	7.9	58	74.6	12.7	1.6	4	1.1
2 1/2 "	65	165.1	127	17.5	72.2	7.9	73.7	90.5	15.9	1.6	4	1.31
3 "	80	184.2	146.1	17.5	85	9.7	86.5	106.4	15.9	1.6	4	1.93
4 "	100	215.9	177.8	17.5	110.1	9.7	111.6	133.4	19.1	3.2	4	2.66
5 "	125	254	209.6	17.5	137	12.7	138.5	160.3	19.1	3.2	8	4.21
6 "	150	279.4	235	17.5	164.5	12.7	166	185.7	19.1	3.2	8	4.68
8 "	200	336.6	292.1	17.5	215.5	12.7	217	241.3	22.2	3.2	8	6.66
10 "	250	406.4	355.6	22.2	269.5	16	271	298.5	27	3.2	8	11.49
12 "	300	457.2	406.4	22.2	321	19.1	322.5	349.3	28.6	4.8	12	15.14

BS10 TABLE D

BS10:1962

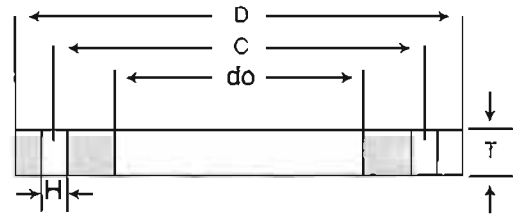

Nominal Pipe Size	Outside Diam	BORE	Thickness	Bolt circle diam	Diam of Bolt	Number of holes	Weight / kg	
							Slip on	Blind
T/D	D	do	T	C	H	N		
15MM	95.3	22	4.8	66.7	14.3	4	0.23	0.25
20MM	101.6	27.6	4.8	73	14.3	4	0.26	0.29
25MM	114.3	34.4	4.8	82.6	14.3	4	0.33	0.37
32MM	120.7	43.1	6.4	87.3	14.3	4	0.46	0.55
40MM	133.4	49	6.4	98.4	14.3	4	0.56	0.68
50MM	152.4	61.1	7.9	114.3	17.5	4	0.89	1.08
65MM	165.1	77.1	7.9	127	17.5	4	0.97	1.28
80MM	184.2	90.3	9.5	146.1	17.5	4	1.43	1.93
100MM	215.9	115.9	9.5	177.8	17.5	4	1.87	2.67
125MM	254	141.6	12.7	209.6	17.5	8	3.31	4.90
150MM	279.4	170.5	12.7	235	17.5	8	3.72	5.96
200MM	336.6	221.8	12.7	292.1	17.5	8	4.87	8.72
250MM	406.4	276.2	15.9	355.6	22.2	8	8.41	15.92
300MM	457.2	327.6	19.1	406.4	22.2	12	11.37	24.12
350MM	527.1	359.7	22.2	489.9	25.4	12	19.47	37.24
400MM	577.9	411.0	22.2	520.7	25.4	12	21.92	44.93
450MM	641.4	462.5	25.4	584.2	25.4	12	30.29	63.54
500MM	704.9	513.6	28.6	641.4	25.4	16	40.03	86.29
600MM	825.5	616.5	31.8	755.7	28.6	16	57.5	131.68



BS10 TABLE E

BS10:1962

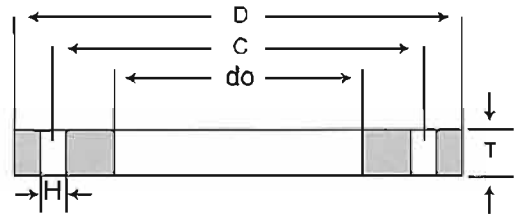

Nominal Pipe Size	Outside Diam	BORE	Thickness	Bolt circle diam	Diam of Bolt	Number of holes	Weight / kg	
							Slip on	Blind
T/E	D	do	T	C	H	N		
15MM	95.3	22	6.4	66.7	14.3	4	0.3	0.33
20MM	101.6	27.6	6.4	73.0	14.3	4	0.34	0.38
25MM	114.3	34.4	7.1	82.6	14.3	4	0.48	0.54
32MM	120.7	43.1	7.9	87.3	14.3	4	0.58	0.68
40MM	133.4	49	8.7	98.4	14.3	4	0.78	0.92
50MM	152.4	61.1	9.5	114.3	17.5	4	1.07	1.30
65MM	165.1	77.1	10.3	127.0	17.5	4	1.27	1.67
80MM	184.2	90.3	11.1	146.1	17.5	4	1.67	2.25
100MM	215.9	115.9	12.7	177.8	17.5	8	2.47	3.49
125MM	254	141.6	14.3	209.6	17.5	8	3.73	5.51
150MM	279.4	170.5	17.5	235	22.2	8	4.96	8.12
200MM	336.6	221.8	19.1	292.1	22.2	8	7.11	13.01
250MM	406.4	278.2	22.2	355.6	22.2	12	11.47	22.03
300MM	457.2	327.6	25.4	406.4	25.4	12	14.91	31.83
350MM	527.1	359.7	28.6	469.9	25.4	12	25.09	47.98
400MM	577.9	411.0	31.8	520.7	25.4	12	31.4	64.36
450MM	641.4	462.5	34.9	584.2	25.4	16	41.06	86.88
500MM	704.9	513.6	38.1	641.4	25.4	16	53.32	114.95
600MM	825.5	616.5	47.6	755.7	31.8	16	85.16	196.3



河北海浩

CLASS 300 ORIFICE FLANGES	101
CLASS 400 ORIFICE FLANGES	102
CLASS 600 ORIFICE FLANGES	103
CLASS 900 ORIFICE FLANGES	104
CLASS 1500 ORIFICE FLANGES	105
CLASS 2500 ORIFICE FLANGES	106



孔板
法兰参数系列



CLASS300 ORIFICE FLANGES

ANSI B16.36

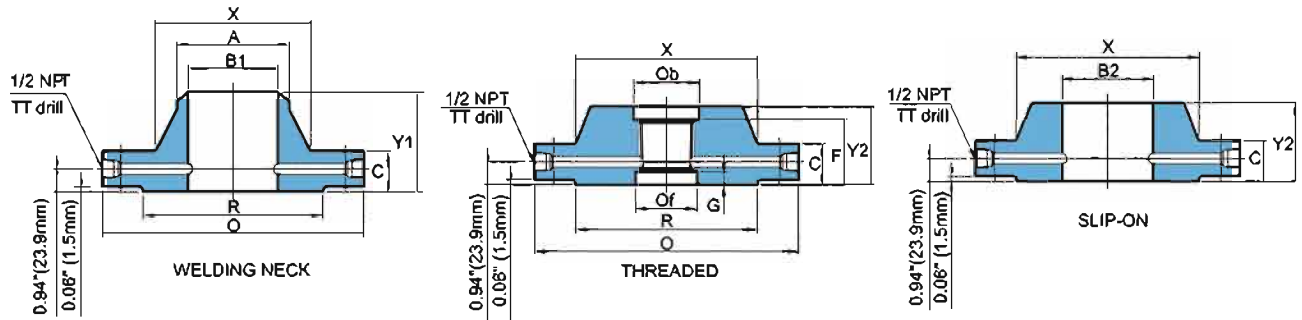

Unit : mm

Nominal Pipe Size	O. D. of Raised Face		Thick-ness of Flange, Min. C	Length Through Hub		Diam. of Hub X	Hub Diam. Beginning of Chamfer (W.N) A	Diam. of Counterbore		Counterbore Depth (From Face)		Bore		Diam. of Press-ure Con-nection (inch) TT	Drilling Template				Bolt Length	
	R	O		Slip-On and Threaded Y2	Weld Neck Y1			Back Ob	Face Of	F	G	Slip-On B2	Weld Neck B1		Bolt Circle	Number of Holes	Diam. of Holes	Diam. of Bolts (inch)	Mach-ine Bolts	Stud Bolts
	To be specified by purchaser.																			
1	50.8	124.0	38.1	47.8	82.6	53.8	33.5	35.8	33.0	36.6	19.1	34.5	1/4	88.9	4	17.5	5/8	114.3	127.0	
1 1/2	73.2	155.4	38.1	47.8	85.9	69.9	48.3	50.5	48.0	37.3	18.3	49.5	1/4	114.3	4	20.6	3/4	120.7	133.4	
2	91.9	165.1	38.1	49.3	85.9	84.1	60.5	63.5	59.9	38.1	17.5	62.0	1/4	127.0	8	17.5	5/8	114.3	127.0	
2 1/2	104.6	190.5	38.1	50.8	88.9	100.1	73.2	76.2	72.1	44.5	14.2	74.7	1/4	149.4	8	20.6	3/4	120.7	133.4	
3	127.0	209.6	38.1	52.3	88.9	117.3	88.9	92.2	87.9	46.0	14.2	90.7	3/8	168.1	8	20.6	3/4	120.7	133.4	
4	157.2	254.0	38.1	53.8	91.9	146.1	114.3	117.6	113.0	47.8	14.2	116.1	1/2	200.2	8	20.6	3/4	120.7	133.4	
6	215.9	317.5	38.1	53.8	100.1	206.2	168.4	171.5	166.9	47.8	7.9	170.7	1/2	269.7	12	22.4	3/4	120.7	133.4	
8	269.7	381.0	41.1	62.0	111.3	260.4	219.2	222.3	217.2	55.6	11.2	221.5	1/2	330.2	12	25.4	7/8	127.0	146.1	
10	323.9	444.5	47.8	66.5	117.3	320.5	273.1	Threaded flanges are furnished in NPS 1-8 only.				276.4	1/2	387.4	16	28.4	1	146.1	165.1	
12	381.0	520.7	50.8	73.2	130.0	374.7	323.9					327.2	1/2	450.9	16	31.8	1 1/8	158.8	177.8	
14	412.8	584.2	53.8	76.2	142.7	425.5	355.6					359.2	1/2	514.4	20	31.8	1 1/8	165.1	184.2	
16	469.9	647.7	57.2	82.6	146.1	482.6	406.4					410.5	1/2	571.5	20	35.1	1 1/4	177.8	196.9	
18	533.4	711.2	60.5	88.9	158.8	533.4	457.2					461.8	1/2	628.7	24	35.1	1 1/4	184.2	203.2	
20	584.2	774.7	63.5	95.3	162.1	587.2	508.0					513.1	1/2	685.8	24	35.1	1 1/4	190.5	215.9	
24	692.2	914.4	69.9	106.4	168.1	701.5	609.6					616.0	1/2	812.8	24	41.1	1 1/2	209.6	241.3	

ORIFICE FLANGES

CLASS400 ORIFICE FLANGES

ANSI B16.36

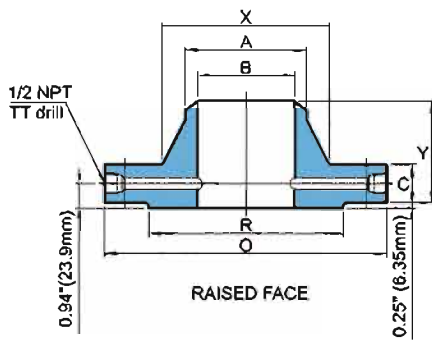

RAISED FACE

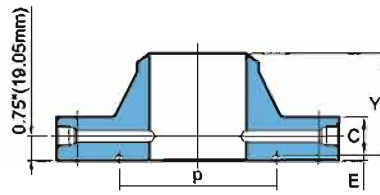

RING TYPE JOINT

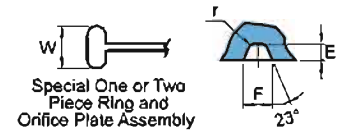

Groove Detail

Unit : mm

Nominal Pipe Size	O. D. of Raised Face	O. D. of Flange	Thick-ness of Flange, Min.	Length Through Hub	Ring Type Joint						Diam. of Hub	Hub Diam. Beginning of Chamfer	Bore	Diam. of Pressure-Connec-tion (inch)	Drilling Template				Lenght of Stud Bolts	
					Groove Number	Pitch Diam.	Groove Depth	Groove Width	Radius at Bottom	Special Oval Ring Height					Bolt Circle	Number of Holes	Diam. of Holes	Diam. of Bolts (inch)	Raised Face	Ring Joint
1	50.8	124.0	36.6	81.0	R16	50.8	6.4	8.7	0.8	25.4	53.8	33.5	To be specified by purchaser	1/4	88.9	4	17.5	5/8	127.0	139.7
1 1/2	73.2	155.4	36.6	84.3	R20	68.3	6.4	8.7	0.8	25.4	69.9	48.3		1/4	114.3	4	20.6	3/4	133.4	139.7
2	91.9	165.1	36.6	84.3	R23	82.6	7.9	11.9	0.8	26.9	84.1	60.5		1/4	127.0	8	17.5	5/8	127.0	139.7
2 1/2	104.6	190.5	36.6	87.4	R26	101.6	7.9	11.9	0.8	26.9	100.1	73.2		1/4	149.4	8	20.6	3/4	133.4	146.1
3	127.0	209.6	36.8	87.4	R31	123.8	7.9	11.9	0.8	26.9	117.3	88.9		3/8	168.1	8	20.6	3/4	133.4	146.1
4	157.2	254.0	38.1	88.9	R37	149.2	7.9	11.9	0.8	26.9	146.1	114.3		1/2	200.2	8	25.4	7/8	139.7	152.4
6	215.9	317.5	41.1	103.1	R45	211.1	7.9	11.9	0.8	26.9	206.2	168.4		1/2	269.7	12	25.4	7/8	158.8	165.1
8	269.7	381.0	47.8	117.3	R49	269.9	7.9	11.9	0.8	26.9	260.4	219.2		1/2	330.2	12	28.4	1	171.5	184.2
10	323.9	444.5	53.8	124.0	R53	323.9	7.9	11.9	0.8	26.9	320.5	273.1		1/2	387.4	16	31.8	1 1/8	190.5	203.2
12	381.0	520.7	57.2	136.7	R57	381.0	7.9	11.9	0.8	26.9	374.7	323.9		1/2	450.9	16	35.1	1 1/4	203.2	215.9
14	412.8	584.2	60.7	149.4	R61	419.1	7.9	11.9	0.8	26.9	425.5	355.6		1/2	514.4	20	35.1	1 1/4	209.6	228.6
16	469.9	647.7	63.5	152.4	R65	469.9	7.9	11.9	0.8	30.2	482.6	406.4		1/2	571.5	20	38.1	1 3/8	222.3	235.0
18	533.4	711.2	68.5	165.1	R69	533.4	7.9	11.9	0.8	30.2	533.4	457.2		1/2	628.7	24	38.1	1 3/8	235.0	241.3
20	584.2	774.7	69.9	168.1	R73	584.2	9.5	13.5	1.5	31.8	587.2	508.0		1/2	685.8	24	41.1	1 1/2	247.7	260.4
24	692.2	914.4	76.2	174.8	R77	692.2	23.8	16.7	1.5	36.6	701.5	609.6		1/2	812.8	24	47.8	1 3/4	279.4	292.1



CLASS600 ORIFICE FLANGES

ANSI B16.36

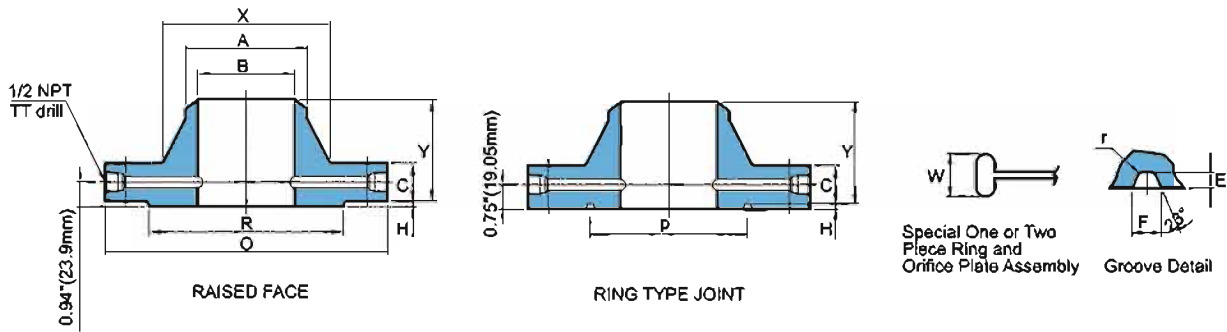

Unit : mm

Nominal Pipe Size	O. D. of Raised Face	O.D. of Flange	Thick-ness of Flange, Min.	Length Through Hub	Height of Raised Face	Ring Type Joint						Diam. of Hub	Hub Diam. Beginning of Chamfer	Bore	Diam. of Pressure Connection (inch)	Drilling Template				Length of Stud Bolts		
						Groove Number	Pitch Diam.	Groove Depth	Groove Width	Radius at Bottom	Special Oval Ring Height					Bolt Circle	Number of Holes	Diam. of Holes		Diam. of Bolts (inch)	Raised Face	Ring Joint
																		Raised Face	Ring Joint			
1	50.8	124.0	36.6	81.0	1.5	R16	50.8	6.4	8.7	0.8	25.4	53.8	33.5	To be specified by purchaser.	1/4	88.9	4	17.5	19.1	5/8	127.0	139.7
1 1/2	73.2	155.4	36.6	84.3	1.5	R20	68.3	6.4	8.7	0.8	25.4	69.9	48.3		1/4	114.3	4	20.6	22.4	3/4	133.4	139.7
2	91.9	165.1	36.6	84.3	1.5	R23	82.6	7.9	11.9	0.8	26.9	84.1	60.5		1/4	127.0	8	17.5	19.1	5/8	127.0	139.7
2 1/2	104.6	190.5	36.6	87.4	1.5	R26	101.6	7.9	11.9	0.8	26.9	100.1	73.2		1/4	149.4	8	20.6	22.4	3/4	133.4	146.1
3	127.0	209.6	36.8	87.4	1.5	R31	123.8	7.9	11.9	0.8	26.9	117.3	88.9		3/8	168.1	8	20.6	22.4	3/4	133.4	146.1
4	157.2	273.1	38.1	101.6	6.4	R37	149.2	7.9	11.9	0.8	26.9	152.4	114.3		1/2	215.9	8	25.4	25.4	7/8	152.4	165.1
6	215.9	355.6	47.8	117.3	6.4	R45	211.1	7.9	11.9	0.8	26.9	222.3	168.4		1/2	292.1	12	28.4	28.4	1	177.8	190.5
8	269.7	419.1	55.6	133.4	6.4	R49	269.9	7.9	11.9	0.8	26.9	273.1	219.2		1/2	349.3	12	31.8	31.8	1 1/8	196.9	209.6
10	323.9	508.0	63.5	152.4	6.4	R53	323.9	7.9	11.9	0.8	26.9	342.9	273.1		1/2	431.8	16	35.1	35.1	1 1/4	222.3	235.0
12	381.0	558.8	66.5	155.4	6.4	R57	381.0	7.9	11.9	0.8	26.9	400.1	323.9		1/2	489.0	20	35.1	35.1	1 1/4	228.6	241.3
14	412.8	603.3	69.9	165.1	6.4	R61	419.1	7.9	11.9	0.8	26.9	431.8	355.6		1/2	527.1	20	38.1	38.1	1 3/8	241.3	254.0
16	469.9	685.8	76.2	177.8	6.4	R65	469.9	7.9	11.9	0.8	30.2	495.3	406.4		1/2	603.3	20	41.1	41.1	1 1/2	260.4	273.1
18	533.4	743.0	82.6	184.2	6.4	R69	533.4	7.9	11.9	0.8	30.2	546.1	457.2		1/2	654.1	20	44.5	44.5	1 5/8	279.4	292.1
20	584.2	812.8	88.9	190.5	6.4	R73	584.2	9.5	13.5	1.5	31.8	609.6	508.0		1/2	723.9	24	44.5	44.5	1 5/8	298.5	317.5
24	692.2	939.8	101.6	203.2	6.4	R77	692.2	11.1	16.7	1.5	36.6	717.6	609.6		1/2	836.2	24	50.8	50.8	1 7/8	336.6	349.3

ORIFICE FLANGES

CLASS900 ORIFICE FLANGES

ANSI B16.36

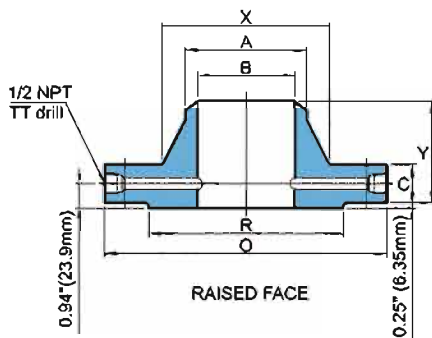

RAISED FACE

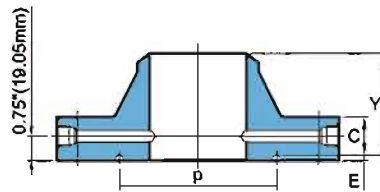

RING TYPE JOINT

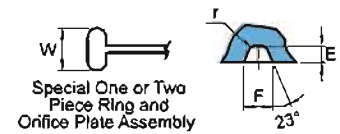

Groove Detail

Unit : mm

Nominal Pipe Size	O. D. of Raised Face	O. D. of Flange	Thick-ness of Flange, Min.	Length Through Hub	Ring Type Joint						Diam. of Hub	Hub Diam. Beginning of Chamfer	Bore	Diam. of Pressure-Connec-tion (inch)	Drilling Template				Lenght of Stud Bolts	
					Groove Number	Pitch Diam.	Groove Depth	Groove Width	Radius at Bottom	Special Oval Ring Height					Bolt Circle	Number of Holes	Diam. of Holes	Diam. of Bolts (inch)	Raised Face	Ring Joint
1	50.8	149.4	38.1	82.6	R16	50.8	6.4	8.7	0.8	25.4	52.3	33.5	To be specified by purchaser	1/4	101.6	4	25.4	7/8	152.4	158.8
1 1/2	73.2	177.8	38.1	88.9	R20	68.3	6.4	8.7	0.8	25.4	69.9	48.3		1/4	124.0	4	28.4	1	158.8	165.1
2	91.9	215.9	38.1	101.6	R24	85.3	7.9	11.9	0.8	26.9	104.6	60.5		1/4	165.1	8	25.4	7/8	152.4	165.1
2 1/2	104.6	244.3	41.1	104.6	R27	108.0	7.9	11.9	0.8	26.9	124.0	73.2		1/4	190.5	8	28.4	1	165.1	177.8
3	127.0	241.3	38.1	101.6	R31	123.8	7.9	11.9	0.8	28.9	127.0	88.9		3/8	190.5	8	25.4	7/8	152.4	165.1
4	157.2	292.1	44.5	114.3	R37	149.2	7.9	11.9	0.8	26.9	158.8	114.3		1/2	235.0	8	31.8	1 1/8	177.8	190.5
6	215.9	381.0	55.6	139.7	R45	211.1	7.9	11.9	0.8	26.9	235.0	168.4		1/2	317.5	12	31.8	1 1/8	196.9	209.6
8	269.7	469.9	63.5	162.1	R49	269.9	7.9	11.9	0.8	26.9	298.5	219.2		1/2	393.7	12	38.1	1 3/8	228.6	241.3
10	323.9	546.1	69.9	184.2	R53	323.9	7.9	11.9	0.8	26.9	368.3	273.1		1/2	469.9	16	38.1	1 3/8	241.3	254.0
12	381.0	609.6	79.2	200.2	R57	381.0	7.9	11.9	0.8	26.9	419.1	323.9		1/2	533.4	20	38.1	1 3/8	260.4	273.1
14	412.8	641.4	85.9	212.9	R62	419.1	11.1	16.7	1.5	33.3	450.9	355.6		1/2	558.8	20	41.1	1 1/2	279.4	292.1
16	469.9	704.9	88.9	215.9	R66	469.9	11.1	16.7	1.5	36.6	508.0	406.4		1/2	616.0	20	44.5	1 5/8	292.1	304.8
18	533.4	787.4	101.6	228.6	R70	533.4	12.7	19.8	1.5	39.6	565.2	457.2		1/2	685.8	20	50.8	1 7/8	330.2	349.3
20	584.2	857.3	108.0	247.7	R74	584.2	12.7	19.8	1.5	39.6	622.3	508.0		1/2	749.3	20	53.8	2	355.6	374.7
24	692.2	1041.4	139.7	292.1	R78	692.2	15.9	27.0	2.3	47.8	749.3	609.6		1/2	901.7	20	66.5	2 1/2	444.5	469.9



CLASS1500 ORIFICE FLANGES

ANSI B16.36

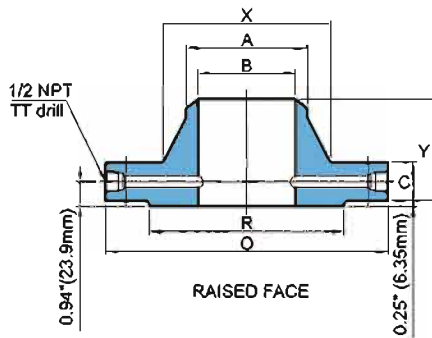

RAISED FACE

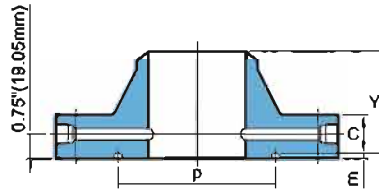

RING TYPE JOINT

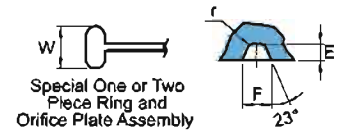

Groove Detail

Unit : mm

Nominal Pipe Size	O. D. of Raised Face	O.D. of Flange	Thick-ness of Flange, Min.	Length Through Hub	Ring Type Joint						Diam. of Hub	Hub Diam. Beginning of Chamfer	Bore	Diam. of Press-ure Connec-tion (inch)	Drilling Template				Lenght of Stud Bolts	
					Groove Number	Pitch Diam.	Groove Depth	Groove Width	Radius at Bottom	Special Oval Ring Height					Bolt Circle	Number of Holes	Diam. of Holes	Diam. of Bolts (inch)	Raised Face	Ring Joint
1	50.8	149.4	38.1	82.6	R16	50.8	6.4	8.7	0.8	25.4	52.3	33.5	To be specified by purchaser.	1/4	101.6	4	25.4	7/8	152.4	158.8
1 1/2	73.2	177.8	38.1	88.9	R20	68.3	6.4	8.7	0.8	25.4	69.9	48.3		1/4	124.0	4	28.4	1	158.8	165.1
2	91.9	215.9	38.1	101.6	R24	95.3	7.9	11.9	0.8	26.9	104.6	60.5		1/4	165.1	8	25.4	7/8	152.4	165.1
2 1/2	104.6	244.3	41.1	104.6	R27	108.0	7.9	11.9	0.8	26.9	124.0	73.2		1/4	190.5	8	28.4	1	165.1	177.8
3	127.0	266.7	47.8	117.3	R35	136.5	7.9	11.9	0.8	26.9	133.4	88.9		3/8	203.2	8	31.8	1 1/8	184.2	184.2
4	157.2	311.2	53.8	124.0	R39	161.9	7.9	11.9	0.8	26.9	162.1	114.3		1/2	241.3	8	35.1	1 1/4	203.2	215.9
6	215.9	393.7	62.6	171.5	R46	211.1	9.5	13.5	1.5	28.4	228.6	168.4		1/2	317.5	12	38.1	1 3/8	266.7	279.4
8	269.7	482.6	91.9	212.9	R50	269.9	11.1	16.7	1.5	33.3	292.1	219.2		1/2	393.7	12	44.5	1 5/8	298.5	311.2
10	323.9	584.2	108.0	254.0	R54	323.9	11.1	16.7	1.5	33.3	368.3	273.1		1/2	482.6	12	50.8	1 7/8	342.9	355.6
12	381.0	673.1	124.0	282.4	R58	381.0	14.3	20.5	1.5	39.6	450.9	323.9		1/2	571.5	16	53.8	2	381.0	400.1
14	412.8	749.3	133.4	298.5	R63	419.1	15.9	27.0	2.3	44.5	495.3	355.6		1/2	635.0	16	60.5	2 1/4	412.8	445.0
16	469.9	825.5	146.1	311.2	R67	469.9	17.5	30.1	2.3	50.8	552.5	406.4		1/2	704.9	16	66.5	2 1/2	450.9	482.6
18	533.4	914.4	162.1	327.2	R71	533.4	17.5	30.2	2.3	50.8	596.9	457.2		1/2	774.7	16	73.2	2 3/4	501.7	533.4
20	584.2	984.3	177.8	355.6	R75	584.2	17.5	33.3	2.3	53.8	641.4	508.0		1/2	831.9	16	79.2	3	546.1	571.5
24	692.2	1168.4	203.2	406.4	R79	692.2	20.6	36.5	2.3	58.7	762.0	609.6		1/2	990.6	16	91.9	3 1/2	622.3	660.4

ORIFICE FLANGES

CLASS2500 ORIFICE FLANGES

ANSI B16.36

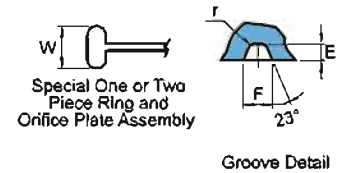
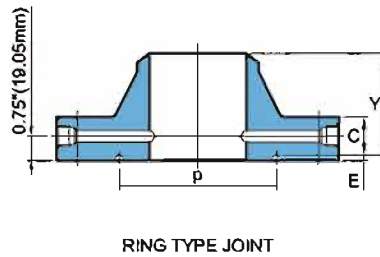
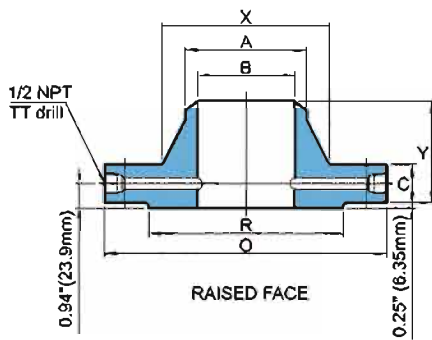

Unit : mm

Nominal Pipe Size	O. D. of Raised Face	O.D. of Flange	Thick-ness of Flange, Min.	Length Through Hub	Ring Type Joint						Diam. of Hub	Hub Diam. Beginning of Chamfer	Bore	Diam. of Pressure-Connec-tion (inch)	Drilling Template				Lenght of Stud Bolts	
					Groove Number	Pitch Diam.	Groove Depth	Groove Width	Radius at Bottom	Special Oval Ring Height					Bolt Circle	Number of Holes	Diam. of Holes	Diam. of Bolts (inch)	Raised Face	Ring Joint
						P	E	F	r max.	W										
1	50.8	158.8	38.1	91.9	R18	60.3	6.4	8.7	0.8	25.4	57.2	33.5	To be specified by purchaser.	1/4	108.0	4	25.4	7/8	152.4	158.8
1 1/2	73.2	203.2	44.5	111.3	R23	82.6	7.9	11.9	0.8	26.9	79.2	48.3		1/4	146.1	4	31.8	1 1/8	177.8	190.5
2	91.9	235.0	50.8	127.0	R26	101.6	7.9	11.9	0.8	26.9	95.3	60.5		1/4	171.5	8	28.4	1	184.2	196.9
2 1/2	104.6	266.7	57.2	142.7	R28	111.1	9.5	13.5	1.5	30.2	114.3	73.2		1/4	196.9	8	31.8	1 1/8	203.2	215.9
3	127.0	304.8	66.5	168.1	R32	127.0	9.5	13.5	1.5	30.2	133.4	88.9		3/8	228.6	8	35.1	1 1/4	228.6	241.3
4	157.2	355.6	76.2	190.5	R38	157.2	11.1	16.7	1.5	33.3	165.1	114.3		1/2	273.1	8	41.1	1 1/2	260.4	273.1
6	215.9	482.6	108.0	273.1	R47	228.6	12.7	19.8	1.5	38.6	235.0	168.4		1/2	368.3	8	53.8	2	349.3	368.3
8	269.7	552.5	127.0	317.5	R51	279.4	14.3	23.0	1.5	39.6	304.8	219.2		1/2	438.2	12	53.8	2	387.4	406.4
10	323.9	673.1	165.1	419.1	R55	342.9	17.5	30.2	2.3	47.8	374.7	273.1		1/2	539.8	12	66.5	2 1/2	489.0	514.4
12	381.0	762.0	184.2	463.6	R60	406.4	17.5	33.3	2.3	50.8	441.5	323.9		1/2	619.3	12	73.2	2 3/4	539.8	571.5



河北海浩

CLASS 150 & CLASS 300 SPECTACLE BLINDS FLANGES. 108

CLASS 600 & CLASS 900 SPECTACLE BLINDS FLANGES. 109

CLASS 1500 & CLASS 2500 SPECTACLE BLINDS FLANGES. 110



八字盲板
法兰参数系列

SPECTACLE BLIND FLANGES

Dimensions Spectacle Blinds - ASME B16.48

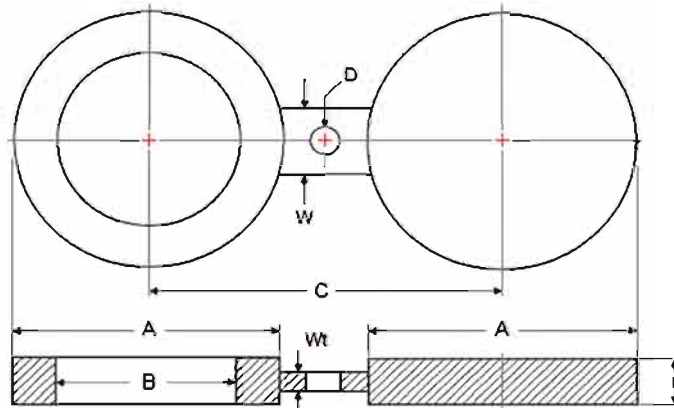

NPS	Class 150					Class 300				
	Outside Ø	Inside Ø	Center Line	THK	Web Width	Outside Ø	Inside Ø	Center Line	THK	Web Width
	A	B	C	t	W	A	B	C	t	W
1/2	45	16	60	3	38	51	16	65	6.4	38
3/4	54	21	70	3	38	64	21	80	6.4	38
1	64	27	80	3	38	70	27	90	6.4	38
1¼	73	42	90	6.4	38	79	42	100	6.4	38
1½	83	48	100	6.4	38	92	48	115	6.4	38
2	102	61	120	6.4	51	108	61	125	9.7	51
2½	107	73	140	6.4	51	127	73	150	9.7	51
3	133	89	150	6.4	64	146	89	170	9.7	64
3½	159	102	175	9.7	64	162	102	185	12.7	64
4	172	114	190	9.7	64	178	114	200	12.7	64
5	194	141	215	9.7	76	213	141	235	15.7	76
6	219	168	240	12.7	76	248	168	270	15.7	76
8	276	219	300	12.7	76	305	219	330	22.4	76
10	337	273	360	15.7	102	359	273	385	25.4	102
12	406	324	430	19.1	102	419	324	450	28.4	102
14	448	356	475	19.1	108	483	356	515	31.8	108
16	511	406	460	22.4	108	536	406	570	38.1	108
18	546	457	580	25.4	114	594	457	630	41.1	114
20	603	508	635	28.4	121	651	508	685	44.5	121
24	714	610	750	31.8	140	772	610	810	50.8	140
NPS	Outside Ø	Inside Ø	Center Line	THK	Web Width	Outside Ø	Inside Ø	Center Line	THK	Web Width
	A	B	C	t	W	A	B	C	t	W



Dimensions Spectacle Blinds - ASME B16.48

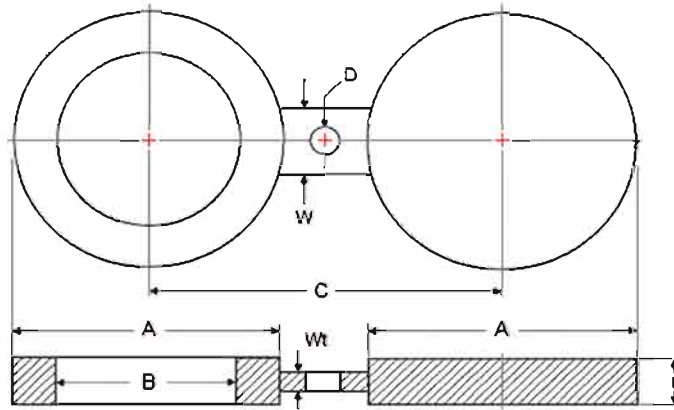

NPS	Class600					Class900				
	Outside Ø	Inside Ø	Center Line	THK	Web Width	Outside Ø	Inside Ø	Center Line	THK	Web Width
	A	B	C	t	W	A	B	C	t	W
1/2	51	16	65	6.4	38	60	16	80	6.4	38
3/4	64	21	80	6.4	38	67	21	90	6.4	41
1	70	27	90	6.4	57	76	27	100	6.4	57
1¼	79	37	100	9.7	57	86	37	110	9.7	57
1½	92	43	115	9.7	67	95	43	125	9.7	67
2	108	55	125	9.7	57	140	55	165	12.7	57
2½	127	67	150	12.7	67	162	67	190	12.7	67
3	146	83	170	12.7	67	165	83	190	15.7	67
4	191	108	215	15.7	76	203	108	235	19.1	76
5	238	135	265	19.1	86	244	135	280	22.4	86
6	264	162	290	22.4	86	286	162	320	25.4	86
8	318	212	350	28.4	95	356	212	395	35.1	95
10	397	265	430	35.1	105	432	265	470	41.1	105
12	454	315	490	41.1	105	495	315	535	47.8	105
14	489	346	525	44.5	114	518	346	560	53.8	114
16	562	397	605	50.8	124	572	397	615	60.5	124
18	610	448	655	53.8	133	635	448	685	66.5	133
20	679	497	725	63.5	133	696	497	750	73.2	133
24	787	597	840	73.2	152	835	597	900	88.9	152
NPS	Outside Ø	Inside Ø	Center Line	THK	Web Width	Outside Ø	Inside Ø	Center Line	THK	Web Width
	A	B	C	t	W	A	B	C	t	W

SPECTACLE BLIND FLANGES

Dimensions Spectacle Blinds - ASME B16.48

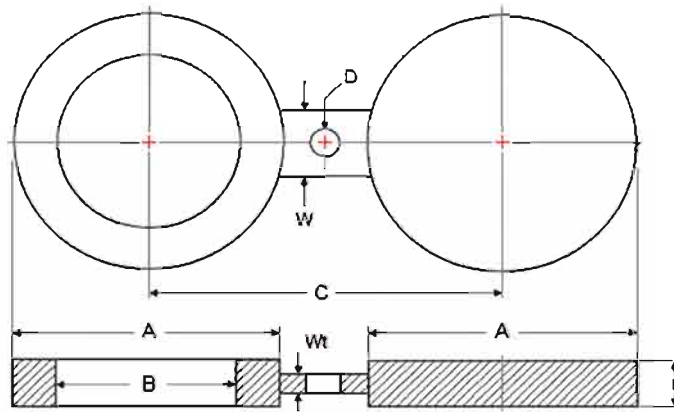

NPS	Class 1500					Class 2500				
	Outside Ø	Inside Ø	Center Line	THK	Web Width	Outside Ø	Inside Ø	Center Line	THK	Web Width
	A	B	C	t	W	A	B	C	t	W
1/2	61	16	80	6.4	38	67	16	90	9.7	38
3/4	67	21	90	9.7	41	73	21	95	9.7	41
1	76	27	100	9.7	64	83	27	110	9.7	64
1¼	86	35	110	9.7	64	102	35	130	12.7	64
1½	95	41	125	12.7	70	114	41	145	15.7	70
2	140	53	165	12.7	70	143	53	170	15.7	70
2½	162	63	190	15.7	76	165	63	195	19.1	76
3	172	78	205	19.1	76	194	78	230	22.4	76
4	206	102	240	22.4	89	232	102	275	28.4	89
5	251	128	290	28.4	89	276	128	325	35.1	89
6	279	154	320	35.1	89	314	154	370	41.1	89
8	349	203	395	41.1	102	384	198	440	53.8	102
10	432	255	480	50.8	114	473	248	540	66.5	114
12	518	303	570	60.5	114	546	289	620	79.2	114
14	575	333	635	66.5	127	-	-	-	-	-
16	638	381	705	76.2	133	-	-	-	-	-
18	702	429	775	85.9	146	-	-	-	-	-
20	752	478	830	95.3	152	-	-	-	-	-
24	899	575	990	111	178	-	-	-	-	-
NPS	Outside	Inside Ø	Center	THK	Web	Outside	Inside Ø	Center	THK	Web
	A	B	C	t	W	A	B	C	t	W



河北海浩

CLASS 150 & CLASS 300 SPADES & RING SPACERS	112
CLASS 600 & CLASS 900 SPADES & RING SPACERS	113
CLASS 1500 & CLASS 2500 SPADES & RING SPACERS	114
COMPARSION FLANGE BORE OF WELDING FLANGE NECK FLANGE FOR ANSI WITH JIS.....	115



插板
法兰参数系列

SPADES & RING SPACERS FLANGES

Dimensions of Spades & Ring Spacers - ASME B16.48

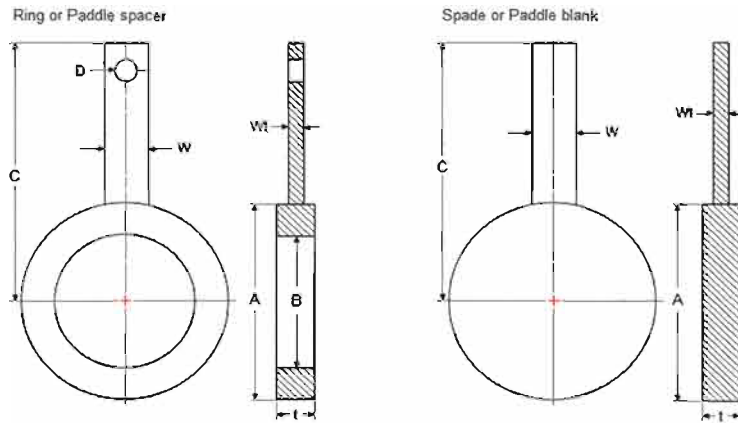

NPS	CLASS150					CLASS300				
	Outside Dia	Inside Dia	Center to End	THK	Handle Width	Outside Dia	Inside Dia	Center to End	THK	Handle Width
	A	B	C	t	W	A	B	C	t	W
1/2	45	16	126	3	32	51	16	129	6.4	32
3/4	54	21	131	3	32	64	21	136	6.4	32
1	64	27	136	3	32	70	27	139	6.4	32
1¼	73	42	145	6.4	32	79	42	150	6.4	32
1½	83	48	145	6.4	32	92	48	150	6.4	32
2	102	61	155	6.4	32	108	61	158	9.7	32
2½	107	73	170	6.4	32	127	73	177	9.7	32
3	133	89	170	6.4	32	146	89	177	9.7	32
3½	159	102	202	9.7	38	162	102	205	12.7	38
4	172	114	202	9.7	38	178	114	205	12.7	38
5	194	141	225	9.7	38	213	141	240	15.7	38
6	219	168	225	12.7	38	248	168	240	15.7	38
8	276	219	267	12.7	38	305	219	281	22.4	38
10	337	273	322	15.7	44	359	273	333	25.4	44
12	406	324	357	19.1	44	419	324	363	28.4	44
14	448	356	378	19.1	44	483	356	395	31.8	44
16	511	406	410	22.4	44	536	406	422	38.1	44
18	546	457	427	25.4	51	594	457	450	41.1	51
20	603	508	455	28.4	51	651	508	480	44.5	51
24	714	610	512	31.8	51	772	610	540	50.8	51
NPS	Outside Dia	Inside Dia	Center to End	THK	Handle Width	Outside Dia	Inside Dia	Center to End	THK	Handle Width
	A	B	C	t	W	A	B	C	t	W



Dimensions of Spades & Ring Spacers - ASME B16.48

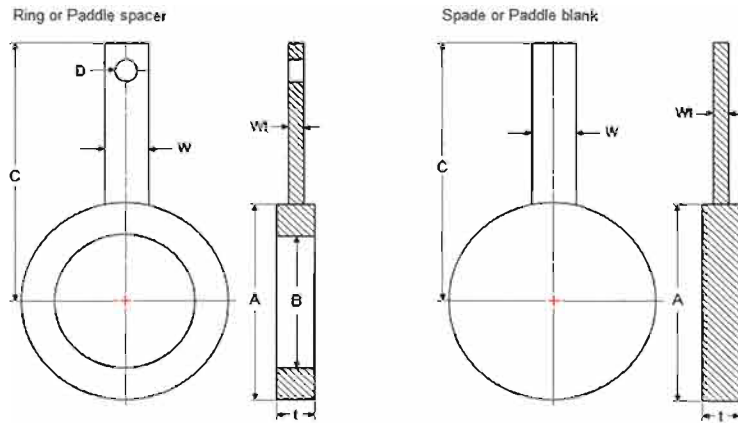

NPS	CLASS600					CLASS900				
	Outside Dia	Inside Dia	Center to End	THK	Handle Width	Outside Dia	Inside Dia	Center to End	THK	Handle Width
	A	B	C	t	W	A	B	C	t	W
1/2	51	16	129	6.4	32	60	16	134	6.4	32
3/4	64	21	136	6.4	32	67	21	137	6.4	32
1	70	27	139	6.4	32	76	27	142	6.4	32
1¼	79	37	150	9.7	32	86	37	151	9.7	32
1½	92	43	150	9.7	32	95	43	151	9.7	32
2	108	55	158	9.7	32	140	55	174	12.7	32
2½	127	67	177	12.7	32	162	67	186	12.7	32
3	146	83	177	12.7	32	165	83	186	15.7	32
4	191	108	211	15.7	38	203	108	217	19.1	38
5	238	135	248	19.1	38	244	135	259	22.4	38
6	264	162	248	22.4	38	286	162	259	25.4	38
8	318	212	288	28.4	38	356	212	307	35.1	38
10	397	265	352	35.1	44	432	265	370	41.1	44
12	454	315	381	41.1	44	495	315	401	47.8	44
14	489	346	398	44.5	44	518	346	412	53.8	44
16	562	397	435	50.8	44	572	397	440	60.5	44
18	610	448	459	53.8	51	635	448	471	66.5	51
20	679	497	493	63.5	51	696	497	501	73.2	51
24	787	597	547	73.2	51	835	597	571	88.9	51
NPS	Outside	Inside	Center	THK	Handle	Outside	Inside	Center	THK	Handle
	A	B	C	t	W	A	B	C	t	W

SPADES & RING SPACERS FLANGES

Dimensions of Spades & Ring Spacers - ASME B16.48

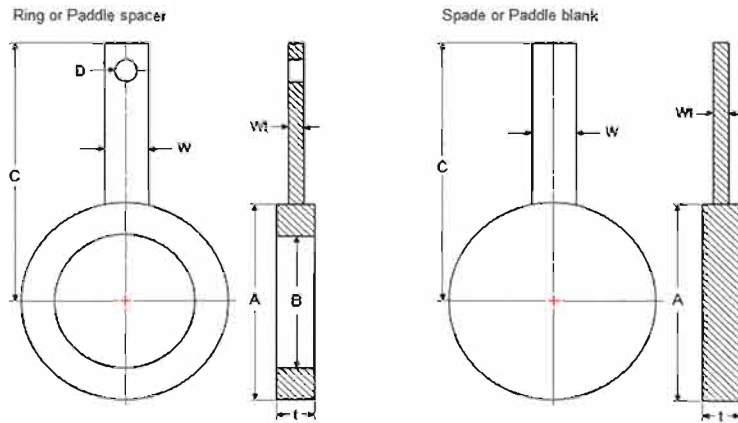

NPS	CLASS1500					CLASS2500				
	Outside	Inside	Center	THK	Handle	Outside	Inside	Center	THK	Handle
	A	B	C	t	W	A	B	C	t	W
1/2	61	16	135	6.4	32	67	16	137	9.7	32
3/4	67	21	137	9.7	32	73	21	140	9.7	32
1	76	27	142	9.7	32	83	27	145	9.7	32
1¼	86	35	151	9.7	32	102	35	161	12.7	32
1½	95	41	151	12.7	32	114	41	161	15.7	32
2	140	53	174	12.7	32	143	53	175	15.7	32
2½	162	63	190	15.7	32	165	63	201	19.1	32
3	172	78	190	19.1	32	194	78	201	22.4	32
4	206	102	219	22.4	38	232	102	232	28.4	38
5	251	128	256	28.4	38	276	128	273	35.1	38
6	279	154	256	35.1	38	314	154	273	41.1	38
8	349	203	303	41.1	38	384	198	321	53.8	38
10	432	255	370	50.8	44	473	248	390	66.5	44
12	518	303	412	60.5	44	546	289	427	79.2	44
14	575	333	442	66.5	44	-	-	-	-	-
16	638	381	472	76.2	44	-	-	-	-	-
18	702	429	504	85.9	51	-	-	-	-	-
20	752	478	530	95.3	51	-	-	-	-	-
24	899	575	603	111.3	51	-	-	-	-	-
NPS	Outside	Inside	Center	THK	Handle	Outside	Inside	Center	THK	Handle
	A	B	C	t	W	A	B	C	t	W



COMPARISON FLANGE BORES OF WELDING NECK FLANGE FOR ANSI WITH JIS

Unit:mm

NOMINAL PIPE SIZE	O.D		SCH10		SCH20		SCH30		STD	SCH40		SCH60		XH	SCH80		SCH100		SCH120		SCH140		SCH160		XXH
	JIS	ANSI	JIS	ANSI	JIS	ANSI	JIS	ANSI	ANSI	JIS	ANSI	JIS	ANSI	ANSI	JIS	ANSI	JIS	ANSI	JIS	ANSI	JIS	ANSI	JIS	ANSI	ANSI
1/2"	21.7	21.34	-	-	-	-	-	-	15.798	16.1	15.798	15.3	-	13.87	14.3	13.87	-	-	-	-	-	-	12.3	11.84	6.4
3/4"	27.2	26.67	-	-	-	-	-	-	20.929	21.4	20.929	20.4	-	18.85	19.4	18.85	-	-	-	-	-	-	16.2	15.60	11.02
1"	34.0	33.40	-	-	-	-	-	-	26.65	27.2	26.65	26.2	-	24.31	25.0	24.31	-	-	-	-	-	-	21.2	20.70	15.22
1 1/4"	42.7	42.16	-	-	-	-	-	-	36.05	35.5	35.05	33.7	-	32.46	32.9	32.46	-	-	-	-	-	-	29.9	29.47	22.76
1 1/2"	48.6	48.26	-	-	-	-	-	-	40.89	41.2	40.89	39.6	-	38.10	38.4	38.1	-	-	-	-	-	-	34.4	33.99	27.94
2"	60.5	60.33	-	-	54.1	-	-	-	52.5	52.7	52.50	50.7	-	49.25	49.5	49.25	-	-	-	-	-	-	43.1	42.90	38.18
2 1/2"	76.3	73.03	-	-	67.3	-	-	-	62.718	65.9	62.71	64.3	-	59.00	62.3	59.00	-	-	-	-	-	-	57.3	53.98	44.98
3"	89.1	88.90	-	-	80.1	-	-	-	77.93	78.1	77.93	75.9	-	73.66	73.9	73.66	-	-	-	-	-	-	68.9	66.65	58.42
3 1/2"	101.6	101.60	-	-	92.6	-	-	-	90.12	90.2	90.12	87.6	-	85.45	85.4	85.45	-	-	-	-	-	-	76.2	-	-
4"	114.3	114.30	-	-	104.5	-	-	-	102.28	102.3	102.26	100.1	-	97.18	97.1	96.18	-	-	92.1	92.05	-	-	87.3	87.33	80.06
5"	139.8	141.30	-	-	129.6	-	-	-	128.19	126.6	128.19	123.6	-	122.25	120.8	122.25	-	-	114.4	115.90	-	-	108.0	109.55	103.20
6"	165.2	168.28	-	-	154.2	-	-	-	154	151	154.0	146.6	-	146.33	143.2	146.33	-	-	136.6	139.73	-	-	128.8	131.8	124.38
8"	216.3	219.08	-	-	203.5	208.38	202.3	205.0	202.72	199.9	202.72	195.7	198.45	193.68	190.9	193.68	186.1	188.95	179.9	182.60	175.1	177.83	170.3	173.05	174.63
10"	267.4	273.05	-	-	254.5	260.35	251.7	257.45	254.51	249.7	254.51	242.0	247.65	247.65	237.2	242.93	230.9	236.58	224.5	230.23	216.5	222.25	210.2	215.90	-
12"	318.5	323.85	-	-	305.7	311.15	301.7	307.09	304.8	297.9	303.23	289.9	295.30	298.45	283.7	288.95	275.7	281.03	267.7	273.05	261.3	266.7	251.9	257.20	-
14"	355.6	355.60	342.8	342.9	339.8	339.70	336.6	336.55	336.55	333	333.35	325.4	325.48	330.2	317.6	317.50	308.0	308.0	300.0	300.08	292.0	292.1	284.2	284.18	-
16"	406.4	406.40	393.6	393.7	390.6	390.53	387.4	387.35	387.35	381.0	381.0	373.4	373.07	381.0	363.6	363.58	353.0	354.03	344.6	344.53	333.4	333.35	325.4	325.48	-
18"	457.2	457.20	444.4	444.5	441.4	441.33	435.0	434.95	438.15	428.6	428.65	419.2	419.1	431.8	409.6	409.8	398.4	398.4	387.4	387.35	377.8	377.85	366.8	366.73	-
20"	508.0	508.0	495.2	495.3	489.0	489.95	482.6	482.60	488.95	477.8	477.88	466.8	466.75	482.6	455.6	455.63	443.0	442.93	431.8	431.80	419.2	419.10	408.0	408.03	-
24"	-	609.6	-	-	-	590.55	-	581.05	590.55	-	574.8	-	560.43	584.2	-	547.73	-	531.83	-	517.55	-	504.85	-	490.58	-
30"	-	762.0	-	-	-	738.6	-	730.25	742.95	-	-	-	-	736.6	-	-	-	-	-	-	-	-	-	-	-



Non Asbestos Gasket, ASME B16.21

DESCRIPTION



(IBC = Inner Bolt Circle, round seal without screw holes)

The centering of the seal is accomplished by the outer diameter of the gasket in combination with the nominal screw diameter, keeping the gasket (ring) in place. Please note that a higher surface pressure can be applied to the seal by using IBC form using the same bolt-torque values. Since the surface pressure has a decisive influence on the sealing-class, an IBC seal is generally the more advantageous option.

Dimensions According to ASME B 16.21 for flanges ASME/ANSI B 16.5

NPS	d1	d2				
		Class				
		150	300	400	600	900
0.5	21	48	54			64
0.75	27	57	67			70
1	33	67	73			79
1.25	42	76	83			89
1.5	49	86	95			99
2	60	105	111			143
2.5	73	124	130			165
3	89	137	149			168
3.5	102	162	165	162	162	-
4	114	175	181	178	194	206
5	141	197	216	213	241	248
6	168	222	251	248	267	289
8	219	279	308	305	321	359
10	279	340	362	359	400	435
12	324	410	422	419	457	498
14	356	451	486	483	492	521
16	406	514	540	536	565	575
18	457	549	597	594	613	638
20	508	607	654	648	683	699
24	610	718	775	768	790	838



Dimensions Spiral Wound Gaskets ASME B16.20

used with RF flanges ASME B16.5

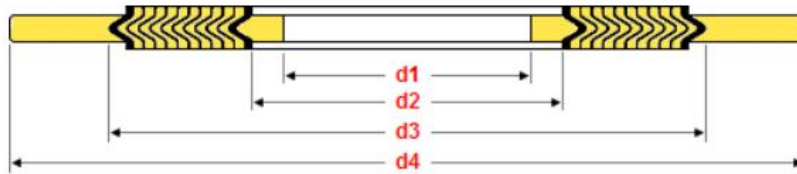

150

300

400

600

900

1500

2500

NPS	Inner Ring	Sealing Element		Outer Ring
	d1	d2	d3	d4
1/2	14.2	19.1	31.8	47.8
3/4	20.6	25.4	39.6	57.2
1	26.9	31.8	47.8	66.8
1.1/4	38.1	47.8	60.5	76.2
1.1/2	44.5	54.1	69.9	85.9
2	55.6	69.9	85.9	104.9
2.1/2	66.5	82.6	98.6	124
3	81	101.6	120.7	136.7
4	106.4	127	149.4	174.8
5	131.8	155.7	177.8	196.9
6	157.2	182.6	209.6	222.3
8	215.9	233.4	263.7	279.4
10	268.2	287.3	317.5	339.9
12	317.5	339.9	374.7	409.7
14	349.3	371.6	406.4	450.9
16	400.1	422.4	463.6	514.4
18	449.3	474.7	527.1	549.4



150

300

400

600

900

1500

2500

NPS	Inner Ring	Sealing Element		Outer Ring
	d1	d2	d3	d4
1/2	14.2	19.1	31.8	54.1
3/4	20.6	25.4	39.6	66.8
1	26.9	31.8	47.8	73.2
1.1/4	38.1	47.8	60.5	82.6
1.1/2	44.5	54.1	69.9	95.3
2	55.6	69.9	85.9	111.3
2.1/2	66.5	82.6	98.6	130.3
3	81	101.6	120.7	149.4
4	106.4	127	149.4	181.1
5	131.8	155.7	177.8	215.9
6	157.2	182.6	209.6	251
8	215.9	233.4	263.7	308.1
10	268.2	287.3	317.5	362
12	317.5	339.9	374.7	422.4
14	349.3	371.6	406.4	485.9
16	400.1	422.4	463.6	539.8
18	449.3	474.7	527.1	596.9
20	500.1	525.6	577.9	654.1
24	603.3	628.7	685.8	774.7



150

300

400

600

900

1500

2500

NPS	Inner Ring	Sealing Element		Outer Ring
	d1	d2	d3	d4
1/2	14.2	19.1	31.8	54.1
3/4	20.6	25.4	39.6	66.8
1	26.9	31.8	47.8	73.2
1.1/4	38.1	47.8	60.5	82.6
1.1/2	44.5	54.1	69.9	95.3
2	55.6	69.9	85.9	111.3
2.1/2	66.5	82.6	98.6	130.3
3	81	101.6	120.7	149.4
4	102.6	120.7	149.4	177.8
5	128.3	147.6	177.8	212.9
6	154.9	174.8	209.6	247.7
8	205.7	225.6	263.7	304.8
10	255.3	274.6	317.5	358.9
12	307.3	327.2	374.7	419.1
14	342.9	362	406.4	482.6
16	389.9	412.8	463.6	536.7
18	438.2	469.9	527.1	593.9
20	489	520.7	577.9	647.7
24	590.6	628.7	685.8	768.4



150

300

400

600

900

1500

2500

NPS	Inner Ring	Sealing Element		Outer Ring
	d1	d2	d3	d4
1/2	14.2	19.1	31.8	54.1
3/4	20.6	25.4	39.6	66.8
1	26.9	31.8	47.8	73.2
1.1/4	38.1	47.8	60.5	82.6
1.1/2	44.5	54.1	69.9	95.3
2	55.6	69.9	85.9	111.3
2.1/2	66.5	82.6	98.6	130.3
3	78.7	101.6	120.7	149.4
4	102.6	120.7	149.4	193.8
5	128.3	147.6	177.8	241.3
6	154.9	174.8	209.6	266.7
8	205.7	225.6	263.7	320.8
10	255.3	274.6	317.5	400.1
12	307.3	327.2	374.7	457.2
14	342.9	362	406.4	492.3
16	389.9	412.8	463.6	565.2
18	438.2	469.9	527.1	612.9
20	489	520.7	577.9	682.8
24	590.6	628.7	685.8	790.7



150

300

400

600

900

1500

2500

NPS	Inner Ring	Sealing Element		Outer Ring
	d1	d2	d3	d4
1/2	14.2	19.1	31.8	63.5
3/4	20.6	25.4	39.6	69.9
1	26.9	31.8	47.8	79.5
1.1/4	33.3	39.6	60.5	88.9
1.1/2	41.4	47.8	69.9	98.6
2	52.3	58.7	85.9	143
2.1/2	63.5	69.9	98.6	165.1
3	78.7	95.3	120.7	168.4
4	102.6	120.7	149.4	206.5
5	128.3	147.6	177.8	247.7
6	154.9	174.8	209.6	289.1
8	196.9	222.3	257.3	358.9
10	246.1	276.4	311.2	435.1
12	292.1	323.9	368.3	498.6
14	320.8	355.6	400.1	520.7
16	374.7	412.8	457.2	574.8
18	425.5	463.6	520.7	638.3
20	482.6	520.7	571.5	698.5
24	590.6	628.7	679.5	838.2



150

300

400

600

900

1500

2500

NPS	Inner Ring	Sealing Element		Outer Ring
	d1	d2	d3	d4
1/2	14.2	19.1	31.8	63.5
3/4	20.6	25.4	39.6	69.9
1	26.9	31.8	47.8	79.5
1.1/4	33.3	39.6	60.5	88.9
1.1/2	41.4	47.8	69.9	98.6
2	52.3	58.7	85.9	143
2.1/2	63.5	69.9	98.6	165.1
3	78.7	92.2	120.7	174.8
4	97.8	117.6	149.4	209.6
5	124.5	143	177.8	254
6	147.3	171.5	209.6	282.7
8	196.9	215.9	257.3	352.6
10	246.1	266.7	311.2	435.1
12	292.1	323.9	368.3	520.7
14	320.8	362	400.1	577.9
16	374.7	406.4	457.2	641.4
18	425.5	463.6	520.7	704.9
20	476.3	514.4	571.5	755.7
24	577.9	616	679.5	901.7



150

300

400

600

900

1500

2500

NPS	Inner Ring	Sealing Element		Outer Ring
	d1	d2	d3	d4
1/2	14.2	19.1	31.8	69.9
3/4	20.6	25.4	39.6	76.2
1	26.9	31.8	47.8	85.9
1.1/4	33.3	39.6	60.5	104.9
1.1/2	41.4	47.8	69.9	117.6
2	52.3	58.7	85.9	146
2.1/2	63.5	69.9	98.6	168.4
3	78.7	92.2	120.7	196.9
4	97.8	117.6	149.4	235
5	124.5	143	177.8	279.4
6	147.3	171.5	209.6	317.5
8	196.9	215.9	257.3	387.4
10	246.1	270	311.2	476.3
12	292.1	317.5	368.3	549.4

General notes..

- Dimensions are in millimeters unless otherwise indicated.
- Image shows a Spiral Wound gasket with Inner - and Outer ring.
- **d1** = Inside diameter when Inner ring is used.
- **d2** = Inside diameter sealing element when no Inner ring is used.
- **d3** = Outside diameter of sealing element.
- **d4** = Outside diameter of Outer ring.
- Thickness of inner and outer ring.. 2.97 mm - 3.33 mm.
- Thickness sealing element.. 4.45 mm.
- Tolerance Outside diameter for NPS 1/2 through NPS 8 is ± 0.8 mm; for NPS 10 through NPS 24 tolerance is $+ 1.5$ mm - 0.8 mm.



美制双头螺栓及螺母

STUD BOLTS AND NUTS

ASTM A193 B7 & A194 2H

ASME B1.1 (UNC/8UN)

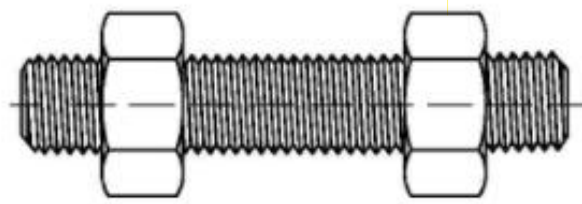

Kg/1000sets

Diameter \ Studs Length	1/2"	5/8"	3/4"	7/8"	1"	1 1/8"	1 1/4"	1 3/8"	1 1/2"	1 5/8"	1 3/4"	1 7/8"	2"
2"	108	-	-	-	-	-	-	-	-	-	-	-	-
2 1/4"	112	191	-	-	-	-	-	-	-	-	-	-	-
2 1/2"	116	198	-	-	-	-	-	-	-	-	-	-	-
2 3/4"	120	204	319	-	-	-	-	-	-	-	-	-	-
3"	128	217	338	494	-	-	-	-	-	-	-	-	-
3 1/4"	132	224	347	507	-	-	-	-	-	-	-	-	-
3 1/2"	136	230	357	520	711	-	-	-	-	-	-	-	-
3 3/4"	140	237	366	533	728	-	-	-	-	-	-	-	-
4"	148	249	385	559	761	1027	-	-	-	-	-	-	-
4 1/4"	152	256	395	572	778	1049	-	-	-	-	-	-	-
4 1/2"	156	262	404	585	795	1071	-	-	-	-	-	-	-
4 3/4"	160	269	414	598	812	1093	-	-	-	-	-	-	-
5"	168	282	433	624	846	1137	1457	-	-	-	-	-	-
5 1/4"	173	288	442	637	862	1159	1484	-	-	-	-	-	-
5 1/2"	177	295	452	650	879	1181	1512	1913	-	-	-	-	-
5 3/4"	185	307	471	676	913	1224	1566	1980	-	-	-	-	-
6"	189	314	480	689	930	1246	1593	2014	2486	3013	3641	4268	-
6 1/4"	-	320	490	702	947	1268	1621	2048	2526	3060	3697	4332	-
6 1/2"	-	327	499	715	963	1290	1648	2081	2566	3108	3752	4397	-
6 3/4"	-	340	518	742	997	1334	1702	2149	2646	3204	3863	4526	-
7"	-	346	528	755	1014	1356	1730	2182	2686	3252	3919	4590	5448
7 1/4"	-	353	537	768	1031	1378	1757	2216	2727	3299	3974	4655	5521
7 1/2"	-	359	547	781	1048	1400	1784	2249	2767	3347	4030	4719	5595
7 3/4"	-	372	566	807	1081	1444	1839	2317	2847	3443	4141	4848	5741
8"	-	378	575	820	1098	1466	1866	2350	2887	3491	4196	4913	5815
8 1/4"	-	-	585	833	1115	1488	1893	2384	2927	3538	4252	4977	5888
8 1/2"	-	-	594	846	1132	1510	1920	2418	2968	3586	4307	5042	5962
8 3/4"	-	-	613	872	1166	1554	1975	2485	3048	3682	4418	5171	6108
9"	-	-	623	885	1183	1576	2002	2519	3088	3730	4474	5235	6182
9 1/2"	-	-	651	924	1233	1641	2084	2620	3208	3873	4640	5429	6402
10"	-	-	670	950	1267	1685	2138	2687	3289	3969	4751	5558	6549
10 1/2"	-	-	-	989	1317	1751	2220	2788	3409	4112	4918	5751	6769
11	-	-	-	1016	1351	1795	2275	2855	3489	4208	5029	5880	6916
11 1/2"	-	-	-	1055	1402	1861	2356	2956	3610	4351	5195	6074	7136
12"	-	-	-	1081	1435	1905	2411	3023	3690	4447	5306	6203	7283
13"	-	-	-	-	-	2015	2547	3192	3891	4686	5584	6525	7650
14"	-	-	-	-	-	2146	2711	3394	4132	4972	5917	6912	8090
15"	-	-	-	-	-	2234	2820	3528	4292	5164	6139	7170	8384
16"	-	-	-	-	-	2366	2983	3730	4533	5450	6472	7557	8824
Thead Number	13unc	11unc	10unc	9unc	8unc	8un	8un	8un	8un	8un	8un	8un	8un
Nut Weight (g/2 Pieces)	60	108	176	270	386	538	714	928	1190	1470	1850	2186	2712



Hex Bolts and Stud Bolt Dimensions for ASME B16.5 Class 150 Flange.

Home > Standard > ASME Fasteners > ASME B16.5 > Class 150 Flanges

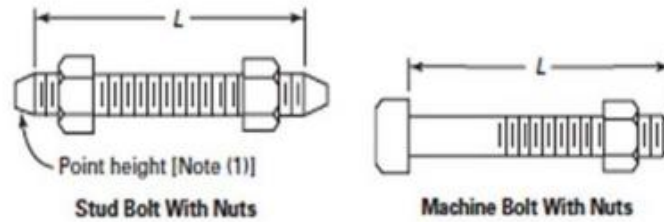

Bolt & Stud Bolt Diameter and Length for ASME B16.5 Class 150 Flanges

Nominal Pipe Size, NPS	Diameter of Bolts, in.	Length of Bolts, L		
		Stud Bolts		Machine Bolts
		2mm Raised Face	Ring Joint	2mm Raised Face
1/2	1/2	55	...	50
3/4	1/2	65	...	50
1	1/2	65	75	55
1 1/4	1/2	70	85	55
1 1/2	1/2	70	85	65
2	5/8	85	95	70
2 1/2	5/8	90	100	75
3	5/8	90	100	75
3 1/2	5/8	90	100	75
4	5/8	90	100	75
5	3/4	95	110	85
6	3/4	100	115	85
8	3/4	110	120	90
10	7/8	115	125	100
12	7/8	120	135	100
14	1	135	145	115
16	1	135	145	115
18	1 1/8	145	160	125
20	1 1/8	160	170	140
24	1 1/4	170	185	150